



Annual Financial Report
at 31 December 2014

Cairo Communication S.p.A.
Head office: Via Tucidide 56, Milan
Share capital Euro 4,073,856.80

Translation into the English language solely for the convenience of international readers

Governance

Board of Directors

Urbano Cairo*	Chairman
Uberto Fornara	Chief Executive Officer
Laura Maria Cairo	Director
Roberto Cairo	Director
Marco Janni	Director
Antonio Magnocavallo	Director
Stefania Petruccioli	Director
Marco Pompignoli	Director
Roberto Rezzonico	Director
Mauro Sala	Director

Control and Risk Committee

Roberto Rezzonico	Director
Mauro Sala	Director
Antonio Magnocavallo	Director

Remuneration Committee

Antonio Magnocavallo	Director
Roberto Rezzonico	Director
Stefania Petruccioli	Director

Related Party Committee

Marco Janni	Director
Mauro Sala	Director
Stefania Petruccioli	Director

Board of Statutory Auditors

Marco Moroni	Chairman
Marco Giuliani	Standing auditor
Maria Pia Maspes	Standing auditor
Emilio Fano	Alternate auditor
Enrico Tamborini	Alternate auditor

Audit Firm

KPMG S.p.A.

* Ordinary and extraordinary executive powers exercised with single signatory, as limited by the Board of Directors

The Group at 31 December 2014

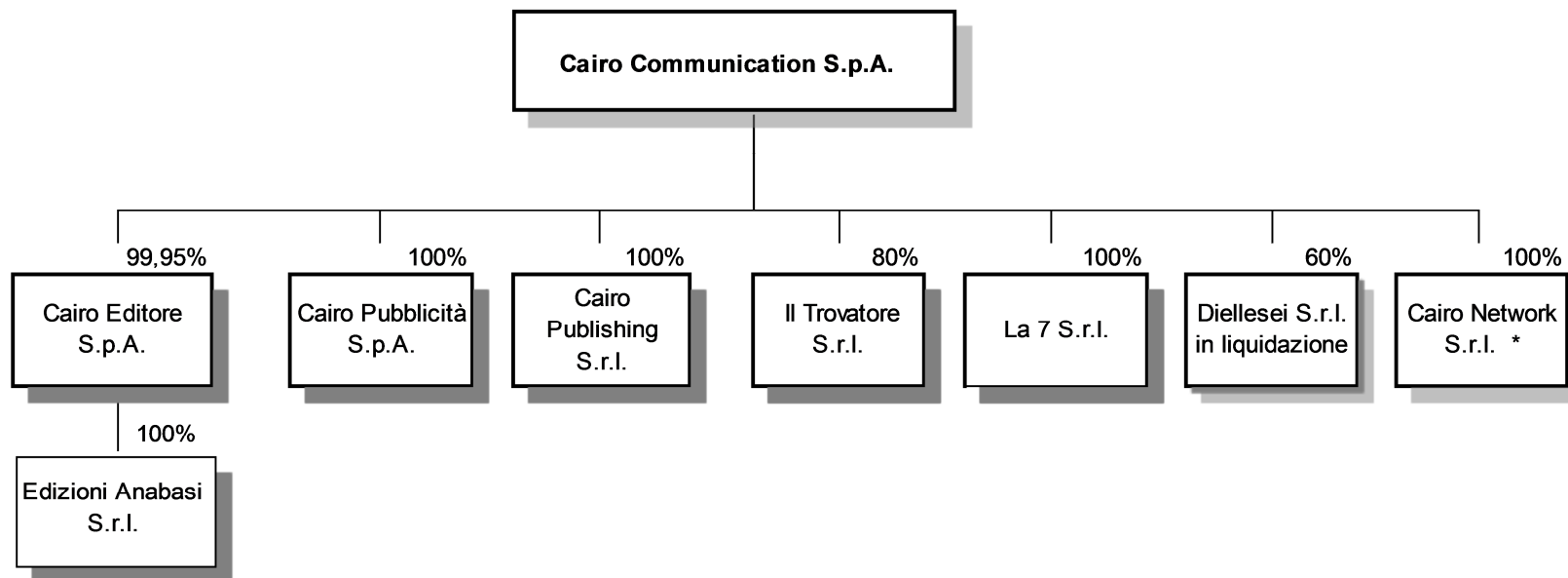

* Effective 1 April 2014, Cairo Sport S.r.l. changed its name into Cairo Network S.r.l.

DIRECTORS' REPORT

Separate and consolidated financial statements at 31 December 2014

Dear Shareholders,

the separate and consolidated financial statements as at and for the year ended 31 December 2014, submitted for your approval, show, respectively, a profit of Euro 10,586 thousand and a profit attributable to the owners of the parent of Euro 23,791 thousand.

In 2014, the Cairo Communication Group, which started operations in the TV publishing field in 2013 following the acquisition of La7, with the upstream integration of its concessionaire business for the sale of advertising space, diversifying its publishing activities previously focused on magazines, operated as a:

- publisher of magazines and books (Cairo Editore/Editoriale Giorgio Mondadori and Cairo Publishing);
- multimedia advertising broker (Cairo Pubblicità) for the sale of advertising space on TV, in print media, on the Internet and in stadiums;
- TV (La7, La7d) and Internet (La7.it, TG.La7.it) publisher.

In 2014, the general economic and financial context, marked by a high degree of uncertainty, continued to report negative effects. To date, there remains uncertainty over the period required for a return to normal market conditions.

Based on AC Nielsen figures, advertising investments in Italy in 2014 amounted to approximately Euro 6.2 billion, down 2.5% versus 2013.

The analysis by media shows that in 2014:

- the magazine advertising market dropped by 6.5% versus 2013, when it had slid by 23.9% versus 2012,
- the TV advertising market basically confirmed (-0.5%) the amounts of 2013, when it had, instead, shed 10% versus 2012.

The uncertainty factors in the short-medium economic term also hit magazine sales figures.

Despite this backdrop, in 2014 the Cairo Communication Group:

- strengthened the results of the cost rationalization measures in the TV publishing segment (La7) implemented during the eight months of activity in 2013, succeeding in achieving also in 2014 a positive gross operating profit (EBITDA) of Euro 9 million, while in the January-December twelve-month period of 2013 (when La7 in the first four months had not been

-
- included yet in the scope of consolidation of the Cairo Communication Group), gross operating loss of La7 had amounted to Euro 25.4 million;
- strengthened the results of “F”, “Settimanale Nuovo” and “Settimanale Giallo”, confirmed the high circulation levels of the other publications, and worked on improving the levels of efficiency reached in containing costs in the magazine publishing segment (production, publishing and distribution);
 - kept advertising revenue levels high, despite the general market trend;
 - achieved highly positive results in its traditional segments (magazine publishing and advertising), despite the general economic and financial context and relevant market trend;
 - took part with the subsidiary Cairo Network in the tender procedure opened by the Ministry of Economic Development for the assignment of rights to use TV frequencies for digital terrestrial broadcasting systems, submitting its binding bid and winning the rights to use a lot of frequencies ("Mux") for a period of 20 years.

To provide a better understanding of the figures for comparative purposes, it should be noted that the 2013 income statement included the results of La7 S.r.l., which was consolidated on 1 May 2013, with regard only to the May-December eight-month period of 2013.

In 2014, consolidated gross operating profit (EBITDA) and operating profit (EBIT) came to Euro 28.2 million and Euro 23 million, growing by 5.6% and 8.9% versus the same results of current operations in 2013 (Euro 26.7 million and Euro 21.1 million). Profit attributable to the owners of the parent came to approximately Euro 23.8 million, increasing sharply by about 24.9% versus the result from current operations in 2013 (Euro 19 million). Mention should be made that profit in 2013 (Euro 74.2 million) had benefited from the recognition in the income statement of “non-recurring income from the acquisition of La7”, amounting to Euro 57.1 million.

Specifically, in 2014:

- in the **TV publishing segment (La7)**, the Group worked on strengthening the results of the rationalization and cost-curbing measures implemented in 2013. Gross operating profit (EBITDA) and operating profit (EBIT) came to approximately Euro 9 million and Euro 6.2 million. Operating profit (EBIT) benefited in the consolidated financial statements from lower amortization and depreciation of Euro 18.2 million, due to the write-down of tangible and intangible assets made in 2013 in the purchase price allocation of the investment. In the January-December twelve-month period of 2013 - when La7 had not been included yet for

the entire period in the scope of consolidation of the Cairo Communication Group - gross operating loss had amounted to approximately Euro 25.4 million.

In 2014, La7's average all-day share was 3.25% and 3.84% in prime time (from 8:30 PM to 11:30 PM), with a high-quality target audience. La7d's share maintained its level at 0.5%. The audience figures of the channel's news and discussion programmes - such as the 8 PM newscast (5.7%), "Otto e mezzo" (5.4%), "Piazza Pulita" (4.8%), "Crozza nel Paese delle Meraviglie" (8%) "Servizio Pubblico" (7.3%), "Anno Uno" (5.5%) "Le invasioni Barbariche" (4.1%), "Coffee Break" (4.9%), "Omnibus" (3.7%), "La Gabbia" (3.4%), "L'aria che tira" (6%), "Bersaglio Mobile" (5%), and "Di martedì" (4.4%) - were positive.

- in the **magazine publishing segment**, gross operating profit (EBITDA) and operating profit (EBIT) came to Euro 13.8 million and Euro 12.5 million, up 11.2% and 13.1% versus 2013 (Euro 12.4 million and Euro 11.1 million). The period under review confirmed the excellent circulation results, with revenue at Euro 73.4 million (Euro 74.8 million in 2013). Regarding weeklies, with over 1.8 million average copies sold in the January-December twelve-month period of 2014, the Group retains its position as the leading publisher in copies of weeklies sold at newsstands, with an over 25% market share;
- in the **advertising segment**, gross operating profit (EBITDA) and operating profit (EBIT) came to Euro 5.2 million and Euro 4 million (Euro 10.6 million and Euro 8 million in 2013). In 2014, gross advertising sales on La7 and La7d channels amounted to Euro 152.9 million (Euro 157.5 million in 2013).

On 12 April 2014, the subsidiary Cairo Network S.r.l. (former Cairo Sport S.r.l.) applied for admission to bid in the auction opened by the Ministry of Economic Development for the awarding of the so-called L3 Lot, put up for tender with a starting price of Euro 31.6 million. This lot includes the granting of rights to use - for a period of 20 years - the 2-SFN multiplex on channels 25 and 59 ("Mux"). The L3 Lot frequencies have an estimated nominal coverage of 96.6% of the population. On 15 May 2014, the Ministry of Economic Development announced the admission of Cairo Network to the tender. On 13 June 2014, the Company submitted its binding bid and won the rights. The award was announced on 26 June 2014. On 25 July 2014, Cairo Network paid the amount offered in its bid (Euro 31.6 million), using own funds of Euro 6.6 million (arising from a capital increase of Euro 5.5 million and a shareholder loan of Euro 1.1 million) and by means of a bank loan of Euro 25 million granted by Unicredit S.p.A.. The loan is secured by a guarantee issued by the parent Cairo Communication, and calls for the payment of

an interest rate equal to the 3-month Euribor plus 225 basis points and certain constraints (negative pledges) and commitments (covenants) on the part of the company, which are typical of these transactions.

On 31 July 2014, the Ministry of Economic Development issued the rights of use.

In January 2015, Cairo Network and EI Towers S.p.A. (“EIT”) entered into the agreements for the realization and subsequent long-term technical management in full service mode (hospitality, service and maintenance, use of broadcasting infrastructure, etc.) of the Mux. The agreements provide, among other things, for:

- a transitional phase, which will see the realization and start-up of the MUX and the initial operations, which will run from the date the agreements were signed to 31 December 2017, and an operational phase of the Mux lasting 17 years (from 2018 to 2034);
- the right to free withdrawal of Cairo Network starting from 1 January 2025;
- guaranteed coverage at full performance of at least 94% of the population, in line with national Muxs with greater coverage;
- consideration to EIT:
 - o during the transitional phase (2015-2017), amounting to a total of Euro 11.5 million for the full three-year period;
 - o at full performance (starting from 2018), amounting to Euro 16.3 million per year.

These amounts include compensation for the availability of the transmitters;

- an annual consideration from EIT to Cairo Network, starting from 2018, ranging between Euro 0 up to Euro 4 million, in the event that the available bandwidth on the Mux is not fully used by Cairo Network.

With the acquisition and realization of the Mux, the Cairo Communication Group will start activities as a network operator and have at its autonomous disposal a broadcasting capacity of about 22.4 Mbps versus the current 7.2 Mbps leased, which can be used to broadcast the La7 and La7d channels from 2017, to broadcast new channels if the Company were to launch any, or even lease them to third parties as early as 2016.

PERFORMANCE

Cairo Communication Group – Consolidated figures

The main **consolidated income statement** figures in 2014 can be compared with the figures in 2013:

(€ thousands)	31/12/2014			31/12/2013		
	Current operations	Non-recurring items	Total	Current operations	Non-recurring items	Total
Gross operating revenue	266,014	-	266,014	276,704	-	276,704
Advertising agency discounts	(25,748)	-	(25,748)	(27,190)	-	(27,190)
Net operating revenue	240,266	-	240,266	249,514	-	249,514
Change in inventories	(28)	-	(28)	(61)	-	(61)
Other revenue and income	11,627	-	11,627	7,985	-	7,985
Total revenue	251,865	-	251,865	257,438	-	257,438
Production cost	(163,048)	-	(163,048)	(181,963)	(1,917)	(183,880)
Personnel expense	(60,634)	-	(60,634)	(48,789)	-	(48,789)
Gross operating profit (EBITDA)	28,183	-	28,183	26,685	(1,917)	24,768
Amortization, depreciation, provisions and impairment losses	(5,221)	-	(5,221)	(5,606)	-	(5,606)
EBIT	22,962	-	22,962	21,079	(1,917)	19,162
Net financial income	1,829	-	1,829	2,901	-	2,901
Income / (loss) on investments	(2)	-	(2)	699	-	699
Non-recurring income from the acquisition of La7 S.r.l.	-	-	-	-	57,066	57,066
Pre-tax profit	24,789	-	24,789	24,679	55,149	79,828
Income tax	(973)	-	(973)	(5,620)	-	(5,620)
Non-controlling interests	(24)	-	(24)	(8)	-	(8)
Profit from continuing operations attributable to the owners of the parent	23,792	-	23,792	19,051	55,149	74,200
Profit / (loss) from discontinued operations	(1)	-	(1)	(6)	-	(6)
Profit attributable to the owners of the parent	23,791	-	23,791	19,045	55,149	74,194

To provide a better understanding of the figures for comparative purposes, it should be noted that:

- the 2013 income statement included the figures of La7 S.r.l., which was consolidated on 1 May 2013, with regard only to the May-December eight-month period of 2013;
- the 2013 profit had benefited from “non-recurring income from the acquisition of La7”.

In 2014, consolidated gross revenue came to approximately Euro 277.6 million (Euro 284.7 million in 2013). The consolidation of La7 S.r.l. for the entire twelve months (as compared to the May-December eight-month period of 2013 included in the same period last year) brought no significant change to revenue, since over 90% of La7 S.r.l. revenue comes from advertising sales generated by Cairo Communication under the advertising concession contract in effect before the acquisition.

In 2014, consolidated gross operating profit (EBITDA) and operating profit (EBIT) came to approximately Euro 28.2 million and Euro 23 million, growing by 5.6% and 8.9% versus the

same results of current operations in 2013 (Euro 26.7 million and Euro 21.1 million). Consolidated profit, amounting to approximately Euro 23.8 million, rose sharply by about 24.9% versus the current operations in 2013 (Euro 19 million). In 2013, profit (Euro 74.2 million) included Euro 55.1 million, that is, non-recurring income and charges from the acquisition of La7. Specifically, “non-recurring income from the acquisition of La7 S.r.l.” referred to the difference between the fair value of assets acquired and liabilities assumed at the date of acquisition and the purchase price paid, given the financial situation of La7 at the date of acquisition.

As mentioned, in 2014, gross operating profit (EBITDA) and operating profit (EBIT) from the TV publishing segment (La7) came to approximately Euro 9 million and Euro 6.2 million. Operating profit (EBIT) benefited in the consolidated financial statements from lower amortization and depreciation of Euro 18.2 million, due to the write-down of tangible and intangible assets made in 2013 in the purchase price allocation of the investment. In 2013, the income statement included the results of La7, specifically the May-December eight-month period of 2013, when gross operating profit (EBITDA) and operating profit (EBIT) from the TV publishing segment (La7) had come to approximately Euro 3.6 million and Euro 2 million. Operating profit (EBIT) from the TV publishing segment (La7) had benefited in the consolidated financial statements from lower amortization and depreciation of Euro 16.5 million, due to the write-down of tangible and intangible assets made in the purchase price allocation of the investment.

The Group **statement of comprehensive income** can be analyzed as follows:

(€ thousands)	31/12/2014	31/12/2013
Consolidated statement of comprehensive income		
Profit attributable to owners of the parent	23,791	74,194
<i>Other non-reclassifiable items of the comprehensive income statement</i>		
Actuarial profit (loss) from defined benefit plans	(1,367)	(510)
Tax effect	376	140
Total comprehensive income	22,800	73,824

The Group’s performance can be read better by analyzing the 2014 results by **main business segment** (magazine publishing, advertising, TV publishing (La7), network operator (Cairo Network) and Il Trovatore) versus those of 2013:

2014	Magazine Publishing	Advertising	TV publishing La7	Trovatore	Network operator Cairo Network	Intra-group and unallocated	Total
(€ thousands)			Current operations	Non-recurring items			
Gross operating revenue	96,708	181,332	110,913	-	834	(123,773)	266,014
Advertising agency discounts	-	(25,748)	-	-	-	-	(25,748)
Net operating revenue	96,708	155,584	110,913	-	834	(123,773)	240,266
Change in inventories	(28)	-	-	-	-	-	(28)
Other income	1,321	919	9,323	-	62	2	11,627
Total revenue	98,001	156,503	120,236	-	896	2	251,865
Production cost	(65,098)	(144,026)	(77,016)	-	(673)	(8)	163,048
Personnel expense	(19,120)	(7,251)	(34,221)	-	(42)	-	(60,634)
Gross operating profit (EBITDA)	13,783	5,226	8,999	-	181	(6)	28,183
Amortization, depreciation, provisions and impairment losses	(1,261)	(1,181)	(2,778)	-	-	(1)	(5,221)
Operating profit (EBIT)	12,522	4,045	6,221	-	181	(7)	22,962
Income / (loss) on investments	-	(2)	-	-	-	-	(2)
Net financial income	17	390	1,423	-	(1)	-	1,829
Non-recurring income from acquisition of La7 S.r.l.	-	-	-	-	-	-	-
Pre-tax profit	12,539	4,433	7,644	-	180	(7)	24,789
Income tax	(4,502)	(1,795)	5,385	-	(61)	-	(973)
Non-controlling interests	-	-	-	-	(24)	-	(24)
Profit from continuing operations attributable to the owners of the parent	8,037	2,638	13,029	-	95	(7)	23,792
Profit / (loss) from discontinued operations	-	-	-	-	-	-	(1)
Profit	8,037	2,638	13,029	-	95	(7)	23,791

2013	Magazine Publishing	Advertising	TV publishing La7 (*)	Trovatore	Network operator Cairo Network	Intra-group and unallocated	Total
(€ thousands)			Current operations	Non-recurring items			
Gross operating revenue	99,063	191,681	77,019	-	485	(91,544)	276,704
Advertising agency discounts	-	(27,190)	-	-	-	-	(27,190)
Net operating revenue	99,063	164,491	77,019	-	485	(91,544)	249,514
Change in inventories	(61)	-	-	-	-	-	(61)
Other income	2,381	5,539	2,391	-	1	-	7,985
Total revenue	101,383	170,030	79,410	-	486	(93,871)	257,438
Production cost	(69,867)	(152,936)	(52,644)	(1,917)	(387)	-	(183,880)
Personnel expense	(19,117)	(6,531)	(23,107)	-	(34)	-	(48,789)
Gross operating profit (EBITDA)	12,399	10,563	3,659	(1,917)	65	-	24,768
Amortization, depreciation, provisions and impairment losses	(1,323)	(2,585)	(1,698)	-	-	-	(5,606)
Operating profit (EBIT)	11,076	7,978	1,961	(1,917)	65	-	19,162
Income / (loss) on investments	-	699	-	-	-	-	699
Net financial income	40	1,165	1,697	-	(1)	-	2,901
Non-recurring income from acquisition of La7 S.r.l.	-	-	-	57,066	-	-	57,066
Pre-tax profit	11,116	9,842	3,658	55,149	64	-	79,828
Income tax	(4,118)	(3,610)	2,131	-	(23)	-	(5,620)
Non-controlling interests	-	-	-	-	(8)	-	(8)
Profit from continuing operations attributable to the owners of the parent	6,998	6,232	5,789	55,149	33	-	74,200
Profit / (loss) from discontinued operations	-	-	-	-	-	-	(6)
Profit	6,998	6,232	5,789	55,149	33	(6)	74,194

The breakdown of **gross operating revenue** in 2014, split up by main business segment (magazine publishing, advertising, TV publishing (La7), network operator (Cairo Network) and Il Trovatore) can be analyzed as follows by comparing the amounts in 2013:

Gross revenue		31/12/2014					
	Magazine publishing	Advertising	TV publishing (La7)	Trovatore	Network operator Cairo Network	Intra-group eliminations and unallocated	Total
Magazine over-the-counter sales	73,400	-	-	-	-	-	73,400
Print media advertising	20,931	27,687	-	-	-	(20,641)	27,977
TV advertising	-	149,636	106,991	-	-	(101,412)	155,215
Stadium signage	-	2,537	-	-	-	-	2,537
Internet advertising	-	870	759	494	-	(878)	1,245
Revenue from concession of programming schedule spaces	-	-	982	-	-	-	982
Other TV revenue	-	-	2,181	-	-	-	2,181
Subscriptions	2,883	-	-	-	-	-	2,883
Books and catalogues	980	-	-	-	-	-	980
Other revenue	-	602	-	340	-	(842)	100
VAT relating to publications	(1,486)	-	-	-	-	-	(1,486)
Total gross operating revenue	96,708	181,332	110,913	834	-	(123,773)	266,014
Other revenue	1,321	919	9,323	62	2	-	11,627
Total revenue	98,029	182,251	120,236	896	2	(123,773)	277,641

Gross revenue		31/12/2013					
	Magazine publishing	Advertising	TV publishing (La7)*	Trovatore	Network operator Cairo Network	Intra-group eliminations and unallocated	Total
Magazine over-the-counter sales	74,791	-	-	-	-	-	74,791
Print media advertising	21,768	28,975	-	-	-	(21,514)	29,229
TV advertising	-	159,194	73,227	-	-	(69,208)	163,213
Stadium signage	-	2,536	-	-	-	-	2,536
Internet advertising	-	396	427	143	-	-	966
Revenue from programming schedule spaces	-	-	1,295	-	-	-	1,295
Other TV revenue	-	-	2,070	-	-	-	2,070
Subscriptions	2,992	-	-	-	-	-	2,992
Books and catalogues	910	-	-	-	-	-	910
Other revenue	-	580	-	342	-	(822)	100
VAT relating to publications	(1,398)	-	-	-	-	-	(1,398)
Total gross operating revenue	99,063	191,681	77,019	485	-	(91,544)	276,704
Other revenue	2,381	5,539	2,391	1	-	(2,327)	7,985
Total revenue	101,444	197,220	79,410	486	-	(93,871)	284,689

(* Figures shown for the "TV publishing" segment refer to the eight-month period from 1 May 2013 to 31 December 2013.

The main figures of the consolidated **statement of financial position** at 31 December 2014 can be analyzed versus the situation at 31 December 2013:

(€ thousands)	31/12/2014	31/12/2013
<u>Assets</u>		
Property, plant and equipment	3,069	2,829
Intangible assets	56,871	12,986
Financial assets	1,175	555
Deferred tax assets	3,983	4,589
Net current assets	(19,071)	(22,390)
Total assets	46,027	(1,431)
Non-current borrowings and provisions	43,741	46,814
(Net financial assets)/Net debt	(124,061)	(172,915)
Equity attributable to the owners of the parent	126,311	124,658
Equity attributable to non-controlling interests	36	12
Total equity and liabilities	46,027	(1,431)

It should be noted that in the consolidated financial statements for the year ended 31 December 2013, the acquisition of La7 S.r.l. had been accounted for under IFRS 3, applying the "acquisition method", by measuring the fair value of identifiable assets and liabilities acquired, considering the future profit-generating capacity of La7 S.r.l. at the date of acquisition. This approach determined:

- the recognition of “provisions for future risks and charges” of Euro 21.4 million, regarding certain contracts whose non-discretionary costs to fulfill obligations exceeded the assumed economic benefits, and specific risk situations related to existing and/or performed contracts and pending and potential litigation,
- the full write-down of non-current assets at the date of acquisition of La7 (30 April 2013), consisting primarily of TV broadcasting rights, and specific technical equipment, whose value was deemed unrecoverable in view of the income prospects of La7 S.r.l. at the acquisition date.

The change in intangible assets versus 31 December 2013 is due primarily to the acquisition, in the tender procedure opened by the Ministry of Economic Development, of the rights to use TV frequencies for digital terrestrial broadcasting systems (Euro 31.6 million plus accessory costs), which also explains the change in the net financial position as described below.

In 2014, as part of the share buy-back plans, no treasury shares were sold or purchased. At 31 December 2014, Cairo Communication held a total of n. 779 treasury shares, or 0.001% of the share capital, subject to art. 2357-ter of the Italian Civil Code.

The consolidated **net financial position** at 31 December 2014, versus the situation at 31 December 2013, can be summarized as follows:

(€ thousands)	31/12/2014	31/12/2013	Change
Cash and cash equivalents	149,061	172,915	(23,854)
Current financial assets	-	-	-
Bank loans	(25,000)	-	(25,000)
Total	124,061	172,915	(48,854)

The change in the net financial position versus 31 December 2013 is mainly due to the investment made by Cairo Network in the acquisition of the Mux (Euro 31.6 million plus accessory costs), and to the distribution of dividends approved by the Shareholders' Meeting on 29 April 2014 (0.27 Euro per share, for a total of Euro 21.2 million).

The bank loan of Euro 25 million, granted by Unicredit S.p.A. and used by Cairo Network to pay the rights of use of the TV frequencies, is secured by a guarantee issued by the parent Cairo Communication, and calls for the payment of an interest rate equal to the 3-month Euribor plus 225 basis points and certain constraints (negative pledges) and commitments (covenants) on the part of the company, which are typical of these transactions.

At 31 December 2014, the net financial position of La7 came to Euro 106.5 million (Euro 115.8 million at 31 December 2013), a change attributable mainly to the dynamics of net working capital and to investments in the purchase of TV rights.

Under the contract to acquire the entire share capital of La7, entered into in April 2013, for a period of 24 months following acquisition, Cairo Communication undertakes to use the financial resources resulting from the contribution received from Telecom Italia Media in the exclusive interest of La7 and to restructure the company, and to not distribute dividends or reserves of La7.

To analyze the major financial indicators, the consolidated asset structure at 31 December 2014 can be examined using a reclassified statement showing increasing liquidity/settlement:

(€ thousands)	31/12/2014	31/12/2013
Non-current assets		
Property, plant and equipment and intangible assets	59,940	15,815
Financial assets	1,175	555
Deferred tax assets	3,983	4,589
Total non-current assets	65,098	20,959
Current assets		
Inventories	3,296	4,104
Trade receivables (unavailable liquid funds)	79,957	90,065
Other unavailable liquid funds	14,969	13,952
Total current operations assets	98,222	108,121
Available liquid funds	149,061	172,915
Total current assets	247,283	281,036
Invested capital	312,381	301,995
Equity	126,347	124,670
Consolidated liabilities		
Post-employment benefits and provisions for risks and charges	43,741	46,814
Non-current financing liabilities	20,000	
Total consolidated liabilities	63,741	46,814
Current liabilities		
Current operating liabilities	117,293	130,511
Non-current financing liabilities	5,000	
Total current liabilities	122,293	130,511
Financing capital	312,381	301,995
Profit	23,791	74,194
Operating profit (EBIT)	22,962	19,162
Sales revenue	240,266	249,514

An analysis of the financial position of the Group using the main financial indicators indicates that the Cairo Communication Group is suitably capitalized to maintain financial equilibrium in the medium/long term and has a very sound equity position as it has significant cash resources, and generates positive results in its traditional segments, and can finance its current operations even within the dynamics of its current assets. Looking at the TV publishing segment, in 2015, the Group will continue to work on strengthening the results of the rationalization and cost-curbing measures achieved in 2013 and 2014.

(€ thousands)	Description	31/12/2014	31/12/2013
Solvency indicators			
Current assets less current liabilities margin	Current assets-current liabilities	124,990	150,525
Current assets less current liabilities ratio	Current assets /current liabilities	2.02	2.15
Treasury margin	(Unavailable liquid funds + available liquid funds)-current liabilities	121,694	146,421
Treasury ratio	(Unavailable liquid funds + available liquid funds)/current liabilities	2.00	2.12
Non-current asset financing indicators			
Own funds less fixed assets margin	Own funds – non-current assets	61,249	103,711
Own funds less fixed assets ratio	Equity /non-current assets	1.9	5.9
Own funds plus non-current liabilities less non-current assets margin	(Own funds+ non-current liabilities) – non-current assets	104,990	150,525
Own funds plus non-current liabilities less non-current assets ratio	(Own funds+ non-current liabilities)/	2.6	8.2
Financing structure indicators			
Total debt ratio	(non-current + current liab.)/Own funds	1.5	1.4
Financing debt ratio	Third-party funds/Own funds	0.2	-
Current operating assets - current operating liabilities		(19,071)	(22,390)
Profitability indicators			
ROE	Profit /Own funds	18.8%	59.5%
ROE current operations *	Profit curr. op./Own funds	18.8%	15.3%
ROI	Operating profit / (Inv. op. capital – op. liabilities)	11.8%	11.2%
ROI current operations	Operating profit current operations/ (Inv. op. capital – op. liabilities)	11.8%	11.2%
Other indicators			
Receivables turnover		101	110

*For 2013, net of non-recurring income and charges from the acquisition of La7

Solvency indicators (liquidity) represent the ability of the company to maintain short-term financial equilibrium, to meet short-term outflows (current liabilities) with existing cash (available liquid funds) and short-term inflows (unavailable liquid funds). Specifically, available and unavailable liquid funds fully cover current liabilities. The statement is used to analyze overall dynamics and origins of cash movements.

The financing structure and non-current assets financing indicators express the strength of equity, and the ability of the company to maintain financial equilibrium in the medium/long term, which depends on:

- the methods of funding medium/long term commitments,
- the composition of funding sources.

Specifically, these indicators, overall, disclose that there are no risks related to stability in the composition of the assets and liabilities/equity.

Regarding profitability indicators, the ROI (Return on Invested capital) is an indicator that expresses the level of efficiency/effectiveness of corporate management. Invested capital as the denominator is restated for an equivalent amount of liabilities without explicit maturity since their cost is substantially included in operating profit.

As further non-financial key performance indicators, the Group mainly uses data relating to circulation and audience ratings that indicate the “success” of each title and programme.

The trend of weeklies and monthlies can be analyzed as follows:

<u>Weeklies</u>	Dipiu'	Diva & donna	Dipiu' TV	Dipiu' TV Cucina	Nuovo	F	TV Mia
ADS average 2014	536,601	202,572	335,709	164,151	213,816	136,755	154,109
ADS average 2013	564,034	205,236	360,563	172,333	231,613	140,250	154,633

<u>Monthlies</u>	For Men Magazine	Natural Style	Bell'Italia	Bell'Europa	In Viaggio	Airone	Gardenia
ADS average 2014	54,894	50,866	51,808	26,727	26,126	61,544	56,298
ADS average 2013	62,962	60,443	52,303	25,860	27,312	63,067	59,275

These figures show how circulation managed to hold ground, despite the tough market in 2014.

In 2014, La7's average all-day share was 3.25% and 3.84% in prime time (from 8:30 PM to 11:30 PM), with a high-quality target audience. La7d's share maintained its level at 0.5%. The audience figures of the channel's news and discussion programmes - such as the 8 PM newscast (5.7%), “Otto e mezzo” (5.4%), “Piazza Pulita” (4.8%), “Crozza nel Paese delle Meraviglie” (8%) “Servizio Pubblico” (7.3%), “Anno Uno” (5.5%) “Le invasioni Barbariche” (4.1%), “Coffee

Break” (4.9%), “Omnibus” (3.7%), “La Gabbia” (3.4%), “L’aria che tira” (6%), “Bersaglio Mobile” (5%), and “Di martedì” (4.4%) - were positive.

Cairo Communication S.p.A. – Parent performance

The main **income statement figures of Cairo Communication S.p.A.** in 2014 can be compared as follows versus those in 2013:

(€ thousands)	31/12/2014	31/12/2013
Gross operating revenue	116,595	121,047
Advertising agency discounts	-	-
Net operating revenue	116,595	121,047
Other revenue and income	350	1,217
Total revenue	116,945	122,264
Production cost	(108,636)	(112,475)
Personnel expense	(2,990)	(2,844)
Gross operating profit (EBITDA)	5,319	6,945
Amortization, depreciation, provisions and impairment losses	(290)	(272)
EBIT	5,029	6,673
Net financial income	365	1,016
Income / (loss) on investments	7,084	13,174
Pre-tax profit	12,478	20,863
Income tax	(1,891)	(2,797)
Profit from continuing operations	10,587	18,066
Profit / (loss) from discontinued operations	(1)	(5)
Profit	10,586	18,061

In 2014, Cairo Communication continued to operate in TV advertising sales (La7, La7d and theme channels Cartoon Network, Boomerang and CNN) and on the Internet through its subsidiary Cairo Pubblicità on a sub-concession basis, invoicing advertising spaces directly to its customers and returning to the sub-grantor Cairo Communication a share of revenue generated by resources managed on a sub-concession basis. Specifically:

- gross operating revenue was approximately Euro 116.6 million (Euro 121 million in 2013);
- parent gross operating profit (EBITDA) was approximately 5.3 million (Euro 6.9 million in 2013);
- operating profit (EBIT) was approximately Euro 5 million (Euro 6.7 million in 2013);
- profit was approximately Euro 10.6 million (Euro 18.1 million in 2013).

“Income (loss) on investments” includes the dividends approved by the subsidiaries Cairo Pubblicità, amounting to Euro 1 million, and Cairo Editore, amounting to Euro 6.2 million, as

well as the value adjustment of the investment held in Cairo Publishing S.r.l., amounting to a negative Euro 0.2 million.

In 2013, the item included the dividends approved by Cairo Pubblicità, amounting to Euro 3.4 million, and by Cairo Editore, amounting to Euro 9.7 million, the gain from the sale of Dmail Group shares, amounting to Euro 327 thousand, as well as the value adjustment of the investment held in Cairo Publishing S.r.l., amounting to a negative Euro 0.3 million.

The Parent's **statement of comprehensive income** can be analyzed as follows:

(€ thousands)	31/12/2014	31/12/2013
Statement of comprehensive income of the Parent		
Profit	10,586	18,061
<i>Other non-reclassifiable items of the comprehensive income statement</i>		
Actuarial profit (loss) from defined benefit plans	(135)	(97)
Tax effect	37	27
Total comprehensive income	10,488	17,991

The main figures of the **statement of financial position** at 31 December 2014 can be analyzed versus the situation at 31 December 2013:

(€ thousands)	31/12/2014	31/12/2013
Assets		
Property, plant and equipment	457	549
Intangible assets	320	356
Financial assets	23,124	17,614
Other non-current assets	1,663	13
Net current assets	7,325	14,961
Total assets	32,889	33,493
Non-current borrowings and provisions	1,485	1,346
(Net financial position)/Net debt	(25,768)	(35,690)
Equity	57,172	67,837
Total equity and liabilities	32,889	33,493

The increase in financial assets amounts to Euro 6.6 million and is attributable to the capitalization of the subsidiary Cairo Network in view of the investment it made to acquire TV frequencies.

As mentioned in the notes to the consolidated statement of financial position, at their Meeting on 29 April 2014, the shareholders approved the distribution of a dividend of 0.27 Euro per share,

inclusive of tax, with coupon detachment date on 12 May 2014 (made payable on 15 May 2014), for a total of Euro 21.2 million.

The **net financial position** of the Parent at 31 December 2014, versus the situation at 31 December 2013, is summarized as follows:

(€ thousands)	31/12/2014	31/12/2013	Change
Cash and cash equivalents	25,768	35,690	(9,922)
Current financial assets	-	-	-
Total	25,768	35,690	(9,922)

Statement of reconciliation of the Parent's equity and profit and Group equity and profit

The **statement of reconciliation** of equity and profit of Cairo Communication S.p.A. and Group equity and profit can be analyzed as follows:

(€ thousands)	Equity	Net profit
Financial statements of Cairo Communication S.p.A.	57,172	10,586
<u>Elimination of the carrying amount of consolidated equity investments:</u>		
Difference between carrying amount of investments and their equity value	120,057	
Share in subsidiaries' profit net of investment impairment losses		1,725
Effects of the purchase price allocation of La7 S.r.l.	(39,414)	18,562
<u>Allocation of excess consideration paid:</u>		
Goodwill	7,198	
Elimination of intra-group profits net of income tax	(19,096)	179
Elimination of intra-group dividends		(7,287)
Consolidated financial statements of Cairo Communication	126,311	23,791

Main business segment operating results and related risk factors and strategic opportunities

PRINT MEDIA PUBLISHING

CAIRO EDITORE - CAIRO PUBLISHING

The results achieved by **Publishing** in 2014 can be analyzed as follows:

Publishing (€ thousands)	31 December 2014	31 December 2013
Operating revenue	96,708	99,063
Other income	1,321	2,381
Change in inventories	(28)	(61)
Total revenue	98,001	101,383
Production cost	(65,098)	(69,867)
Personnel expense	(19,120)	(19,117)
Gross operating profit (EBITDA)	13,783	12,399
Amortization, depreciation, provisions and impairment losses	(1,261)	(1,323)
EBIT	12,522	11,076
Income / (loss) on investments	-	-
Net financial income	17	40
Pre-tax profit	12,539	11,116
Income tax	(4,502)	(4,118)
Non-controlling interests	-	-
Profit from continuing operations attributable to the owners of the parent	8,037	6,998
Profit/ (loss) from discontinued operations	-	-
Profit	8,037	6,998

In 2014, Cairo Editore strengthened the results of its publications and worked on improving the levels of efficiency reached in containing production, publishing and distribution costs. Specifically, in 2014:

- the operating results of the Group's publishing segment increased versus the prior year;
- it confirmed the excellent circulation results, with revenue at Euro 73.4 million versus Euro 74.8 million in 2013,
- Group gross advertising revenue, which reached Euro 27.2 million, dropped by 3.9% versus 2013 (*ACNielsen*, -6.5% the magazine advertising market in 2014).

In the twelve months, gross operating profit (EBITDA) and operating profit (EBIT) came to Euro 13.8 million and Euro 12.5 million, up by 11.2% and 13.1% versus 2013 (Euro 12.4 million and Euro 11.1 million).

The Group weeklies confirmed the excellent circulation results achieved, with an average ADS circulation in the January-December twelve-month period of 2014 of 536,601 copies for "Settimanale DIPIU", 335,709 copies for "DIPIU' TV", 164,151 copies for "Settimanale DIPIU e DIPIU'TV Cucina", 202,572 copies for "Diva e Donna", 213,816 copies for "Settimanale Nuovo", 136,755 copies for "F", 154,109 copies for "TVMia" and 118,495 copies for "Settimanale Giallo", with over 1.8 million average copies sold, and making the Group the leading publisher in copies of weeklies sold at newsstands, with an over 25% market share.

As far as circulation is concerned, the features of the Group's publications and the Group strategy help maintain a strong lead over competitors in the current publishing market. Specifically:

- cover prices of the weeklies are lower, some half the price of those of the main competitors; this gap increases appeal and allows space for potential price increases, hence for increased profitability;
- sales are mostly over-the-counter (95%), with a minimum impact of revenue generated by gifts and sundry editorial material (approximately 2% on total publishing revenue, including advertising), whose sales figures have collapsed in the publishing segment; the Group has opted to focus on the quality of its publications; in 2014, gross advertising revenue generated by the Group's publications accounted for 26% (27% in 2013) - an extremely low figure if compared with the revenue breakdown of other major publishing groups, therefore based to a lesser extent on the economic cycle - while the remaining 74% (73% in 2013) came from direct sales and subscriptions, proof of the high editorial quality of publications;
- weekly magazines, which account for approximately 90% of total publishing sales revenue, are sold as single copies and not bundled with other weeklies and/or dailies to bolster sales;
- the remarkable sales volumes achieved, both in absolute terms and versus Cairo Editore's competitors, make the advertising pages highly appealing in terms of advertising cost per copy sold (equal to the difference between the price of the advertising page and copies sold), currently lower than the publications of its competitors.

In 2015, Cairo Editore will continue to pursue opportunities to optimize production, publishing and distribution costs, which mainly regarded negotiations for the reduction of paper costs, the optimization of bordereau costs, and the revision of certain corporate processes.

ADVERTISING

Looking at the advertising segment, in 2014 the Cairo Communication Group continued to operate as advertising broker - with its subsidiary Cairo Pubblicità - selling space in the print media for Cairo Editore ("For Men Magazine", "Natural Style", "Settimanale DIPIU'", "DIPIU' TV" and weekly supplements "Settimanale DIPIU' e DIPIU'TV Cucina" and "Settimanale DIPIU' e DIPIU'TV Stellare", "Diva e Donna", "TV Mia", "Settimanale Nuovo", "F" and "Settimanale Giallo"), the Editoriale Giorgio Mondadori division ("Bell'Italia", "Bell'Europa",

“In Viaggio”, “Airone”, “Gardenia”, “Arte” and “Antiquariato”) and for Editoriale Genesis (“Prima Comunicazione” and “Uomini e Comunicazione”), for the sale of advertising space on TV for La7 and La7d, and for Turner Broadcasting (Cartoon Network, Boomerang, CNN), on the Internet (La7.it, TG.La7.it, Cartoon Network.it, Cnn.com) and for the sale of stadium signage and space at the Olimpico in Turin for Torino FC.

The results achieved by **Advertising** in 2014 can be analyzed as follows:

Advertising (€ thousands)	31 December 2014	31 December 2013
Gross operating revenue	181,332	191,681
Advertising agency discounts	(25,748)	(27,190)
Net operating revenue	155,584	164,491
Other income	919	5,539
Change in inventories	-	-
Total revenue	156,503	170,030
Production cost	(144,026)	(152,936)
Personnel expense	(7,251)	(6,531)
Gross operating profit (EBITDA)	5,226	10,563
Amortization, depreciation, provisions and impairment losses	(1,181)	(2,585)
EBIT	4,045	7,978
Income / (loss) on investments	(2)	699
Net financial income	390	1,165
Pre-tax profit	4,433	9,842
Income tax	(1,795)	(3,610)
Non-controlling interests	-	-
Profit from continuing operations attributable to the owners of the parent	2,638	6,232
Profit/ (loss) from discontinued operations	-	-
Profit	2,638	6,232

In 2014, total gross advertising revenue, which includes TV advertising revenue invoiced directly by La7 (Euro 6.2 million), came to approximately Euro 187.5 million. Specifically, in 2014, advertising sales on La7 and La7d channels amounted to Euro 152.9 million (Euro 157.5 million in 2013).

For a comparative assessment of the advertising revenue trend, it should also be noted that in 2013 the advertising sales concession contract on Sportitalia channels was consensually terminated, effective 30 April 2013. The contract had generated gross advertising revenue of approximately Euro 2.4 million.

TV PUBLISHING (La7)

As previously mentioned, to provide a better understanding of the figures for comparative purposes, it should be noted that:

- the 2013 income statement included the results of La7 S.r.l., which was consolidated on 1 May 2013, with regard only to the May-December eight-month period of 2013,
- the 2013 result had benefited from the “non-recurring income from the acquisition of La7”.

In 2013, the Group started operations in the TV publishing field with the acquisition from Telecom Italia Media S.p.A. of the entire share capital of La7 S.r.l. as from 30 April 2013. At the acquisition date, the financial situation of La7 had called for the implementation of a restructuring plan aimed at reorganizing and streamlining the corporate structure and at curbing costs, while retaining the high quality levels of the programming.

Starting from May 2013, the Group began to implement its own plan to restructure the company, achieving, as early as the May-December eight-month period of 2013, a positive gross operating profit (EBITDA) of Euro 3.7 million.

(€ thousands)	31 December 2014			31 December 2013		
	Current operations	Non-recurring items	Total	Current operations	Non-recurring items	Total
Operating revenue	110,913	-	110,913	77,019	-	77,019
Change in inventories	-	-	-	-	-	-
Other revenue and income	9,323	-	9,323	2,391	-	2,391
Total revenue	120,236	-	120,236	79,410	-	79,410
Production cost	(77,016)	-	(77,016)	(52,644)	(1,917)	(54,561)
Personnel expense	(34,221)	-	(34,221)	(23,107)	-	(23,107)
Gross operating profit (EBITDA)	8,999	-	8,999	3,659	(1,917)	1,742
Amortization, depreciation, provisions and impairment losses	(2,778)	-	(2,778)	(1,698)	-	(1,698)
EBIT	6,221	-	6,221	1,961	(1,917)	44
Net financial income	-	-	-	-	-	-
Income / (loss) on investments	1,423	-	1,423	1,697	-	1,697
Non-recurring income from acquisition of La7 S.r.l.	-	-	-	-	57,066	57,066
Pre-tax profit	7,644	-	7,644	3,658	55,149	58,807
Income tax	5,385	-	5,385	2,131	-	2,131
Non-controlling interests	-	-	-	-	-	-
Profit attributable to owners of the parent	13,029	-	13,029	5,789	55,149	60,938

(*) Figures shown for 2013 refer to the May-December eight-month period.

In 2014, the Group managed to strengthen the results of the cost rationalization measures implemented in the first eight months of activity in 2013, achieving a positive gross operating

profit (EBITDA) of Euro 9 million, versus the gross operating loss of Euro 25.4 million of La7 in the January-December twelve-month period of 2013.

Operating profit (EBIT) came to Euro 6.2 million and benefited in the consolidated financial statements from lower amortization and depreciation of Euro 18.2 million, due to the write-down of tangible and intangible assets made in 2013 in the purchase price allocation of the investment.

Gross operating profit (EBITDA) in the TV publishing segment in 2014 can be analyzed as follows with the same result of current operations in 2013 (as compared to the May-December eight-month period of 2013 included in the consolidated income statement at 31 December 2013, shown in the interim management report at that date):

(€ thousands)	31/12/2014	31/12/2013
Operating revenue	110,913	114,429
Change in inventories		-
Other revenue and income	9,323	2,879
Total revenue	120,236	117,308
Production cost	(77,016)	(103,635)
Personnel expense	(34,221)	(39,081)
Gross operating profit (EBITDA)	8,999	(25,408)

In 2014, La7's average all-day share was 3.25% and 3.84% in prime time (from 8:30 PM to 11:30 PM), with a high-quality target audience. La7d's share maintained its level at 0.5%. The audience figures of the channel's news and discussion programmes - such as the 8 PM newscast (5.7%), "Otto e mezzo" (5.4%), "Piazza Pulita" (4.8%), "Crozza nel Paese delle Meraviglie" (8%), "Servizio Pubblico" (7.3%), "Anno Uno" (5.5%), "Le invasioni Barbariche" (4.1%), "Coffee Break" (4.9%), "Omnibus" (3.7%), "La Gabbia" (3.4%), "L'aria che tira" (6%), "Bersaglio Mobile" (5%), and "Di martedì" (4.4%) - were positive.

IL TROVATORE

In 2014, Il Trovatore continued operations, mainly providing technological services to develop and maintain the online platforms of the Group's companies.

NETWORK OPERATOR (CAIRO NETWORK)

As mentioned earlier, the subsidiary Cairo Network took part in the tender procedure opened by the Ministry of Economic Development for the assignment of rights to use TV frequencies for

digital terrestrial broadcasting systems, submitting its binding bid and winning the rights to use a lot of frequencies ("Mux") for a period of 20 years.

In January 2015, Cairo Network and EI Towers S.p.A. ("EIT") entered into the agreements for the realization and then long-term technical management in full service mode (hospitality, service and maintenance, use of broadcasting infrastructure, etc.) of the Mux.

With the acquisition and realization of the Mux, the Cairo Communication Group will start operations at the end of 2015 as a network operator.

Alternative performance indicators

In this Report, in order to provide a clearer picture of the financial performance of the Cairo Communication Group, besides of the conventional financial indicators required by IFRS, a number of alternative performance indicators are shown that should, however, not be considered substitutes of those adopted by IFRS.

The alternative indicators are:

- **EBITDA:** used by Cairo Communication as a target to monitor internal management, and in public presentations (to financial analysts and investors). It serves as a unit of measurement to evaluate Group and Parent operational performance, with the EBIT, and is calculated as follows:

Profit from continuing operations, pre tax

+/- Net finance income

+/- Share in associates

EBIT- Operating profit

+ Amortization & depreciation

+ Bad debt impairment losses

+ Provisions for risks

EBITDA – Operating profit, before amortization, depreciation, write-downs and impairment losses

The Cairo Communication Group also considers **net financial position** as a valid indicator of the Group's ability to meet financial obligations, both current and future. As can be seen in the table used above, which details the equity figures used for the calculation of Group net financial position, this figure includes cash and other cash equivalents, bank deposits, securities and other current financial assets, reduced by current and non-current bank borrowings.

Transactions with parents, subsidiaries and associates

In 2014, transactions with related parties, including with Group companies, were not considered to be atypical or unusual, and were part of the ordinary activities of Group companies. These transactions were carried out on market terms, taking account of the goods and services provided.

Information on transactions with related parties is disclosed in Note 36 to the consolidated financial statements and in Note 28 of the separate financial statements.

Main risks and uncertainties to which Cairo Communication S.p.A. and its Group are exposed

Risks associated with the general economic climate

The financial position, results and cash flows of the Cairo Communication Group may be influenced by various factors within the macro-economic environment, such as the increase or decrease of GNP, the level of consumer and corporate confidence, the advertising expenditure/GDP ratio, interest rate trends and cost of raw materials.

In 2014, the general economic and financial climate, marked by a high degree of uncertainty, continued to show its negative effects, creating an increasingly complex competitive scenario. To date, there remains uncertainty over the period required for a return to normal market conditions. Should this situation of uncertainty continue for some time, the operations, strategy and outlook for the Group may be impacted.

To challenge the tough market scenario, the Group implemented, starting in previous periods, and also in 2014, a series of measures to increase efficiency and effectiveness of the production, publishing and distribution processes, and will continue in 2015 to benefit from the high levels of efficiency achieved. Looking at the TV publishing segment, in 2015, the Group will continue to work on strengthening the results of the rationalization and cost-curbing measures achieved in 2013 and 2014.

Risks associated with advertising and publishing market trends

In 2014, the persisting short and medium-term economic uncertainty impacted negatively on the advertising market.

Based on AC Nielsen figures, in 2014 advertising investments in Italy amounted to approximately Euro 6.2 billion, down 2.5% versus 2013 (specifically, -6.5% the magazine advertising market and -0.5% the TV advertising market). The Cairo Communication Group

holds approximately 4.4% of the TV advertising market (4.6% in 2013) and approximately 5.7% of the magazine advertising market (5.5% in 2013). This market share leaves the Group room enough for growth, given the high quality and significant distribution of its own titles, in particular weeklies, and of the TV resources (own and under concession), quality, circulation and audience ratings that provide significant competitive edge.

The economic climate has slowed the pace of the sale of dailies and magazines. Despite the challenging market, in 2014, it confirmed the excellent circulation results, with revenue at Euro 73.4 million versus Euro 74.8 million in 2013.

Advertising

The Cairo Communication Group is significantly exposed to advertising sales performance, which has progressively decreased over time as a result of significant developments in the publishing business. The consolidation of La7 S.r.l. brought no significant change to revenue, since over 90% of La7 S.r.l. revenue is generated by advertising sales made by Cairo Communication under the existing advertising concession contract. Advertising sales are currently the main source of revenue for the TV publishing segment.

Advertising sales today represent approximately 65% (approximately 69% in 2013) of total Group revenue. Considering also advertising revenue directly generated by La7 (approximately Euro 6.2 million), the impact of advertising revenue increases to 68% (approximately 71% in 2013).

Considering the Group's publishing business alone, advertising revenue in 2014 accounted for 26% - much lower than the revenue breakdown of other major publishing groups - while the remaining 74% was generated by distribution and subscription revenue, demonstrating the great publishing strength of advertising products.

The sale of advertising space is monitored daily by reference to the percentage saturation of the catchment time, average sales price and the variation from forecasts. Daily monitoring also enables a review of the sales forecasts by month in order to act – with reference to print media – on advertising pages and thus on the structure of product costs.

Management's attention is focused on the definition of strategy and commercial policy to ensure an effective presentation of the high value of the product offering. The features of the resources offered represent strength for the Group in the current competitive climate.

La7 boasts an exceptional audience profile, particularly appealing in terms of advertising.

Regarding Group titles, the remarkable distribution volumes, in absolute terms and considering competition, which enabled the Group to become the leading publisher of weeklies by copies sold on newsstands make the advertising pages appealing in terms of advertising cost per copy sold (equal to the ratio between the price of the advertising page and the copies sold), which is currently lower than competition.

Distribution

Regarding distribution, the features of the products published by the Group as well as its strategy, are such as to build a significant competitive edge in the current climate of the publishing segment. This is largely explained by the fact that:

- cover prices of the weeklies are lower, some significantly lower than those of the main competitors;
- sales are mostly over-the-counter (95%), with a minimum impact (approximately 2% on total publishing revenue, including advertising) of revenue generated by gifts and sundry editorial materials;
- weekly magazines, which account for approximately 90% of the total publishing segment revenue, are sold as single copies and not bundled with other weeklies and/or dailies to bolster sales.

Risks associated with extraordinary transactions

As mentioned earlier, in 2013 Cairo Communication S.p.A. acquired from Telecom Italia Media, through Cairo Due S.r.l., the entire share capital of La7 S.r.l.

The financial situation of La7 called for the implementation of a restructuring plan aimed at reorganizing and streamlining the corporate structure and at curbing costs, while retaining the high quality levels of the programming schedule.

Starting from May 2013, the Group began to implement its own plan to restructure La7, by adopting the following main guidelines:

- confirming the editorial line and those programs that represent the main strengths of the channel,
- curbing costs, focusing in particular on “unproductive” cost items and items that exceed the cost/benefit ratio, and on recovering efficiency,
- enhancing the high quality of the La7 target audience, to maintain and develop the high level of advertising revenue against the general market backdrop.

In the May-December eight-month period of 2013, La7 current operations, which generated a positive gross operating profit (EBITDA) of Euro 3.7 million, saw no cash absorption.

In 2014, the Group managed to strengthen the results of the cost rationalization measures implemented in the first eight months of activity in 2013, achieving a positive gross operating profit (EBITDA) of Euro 9 million, versus the gross operating loss of Euro 25.4 million of La7 in the January-December twelve-month period of 2013.

Operating profit (EBIT) came to Euro 6.2 million and benefited in the consolidated financial statements from lower amortization and depreciation of Euro 18.2 million, due to the write-down of tangible and intangible assets made in 2013 in the purchase price allocation of the investment.

In 2015, the Group will continue to work on strengthening the results of the rationalization and cost-curbing measures achieved in 2013 and 2014.

Risks associated with developments in the media segment

The media segment has seen an increase in the level of penetration of new communication resources, in particular the Internet, and the new unencrypted theme channels on the digital terrestrial platform, together with technology innovations that may lead to changes in demand by consumers, who in future will probably request personalized content by even directly selecting the source. As a result, this may change the relative importance of the various media and audience distribution, with consequent greater market fragmentation.

Whereas the development of the Internet may impact on the share of print media, mainly on dailies and to a much lesser extent on the weeklies published by the Group, the growth of the Internet and of digital theme television may impact on the generalist TV audience. Any development of new TV channels by the Group may allow it to take advantage of this situation.

The Group constantly monitors the level of penetration of new resources as well as changes in the business model related to the distribution of content available to assess the opportunity to develop the various distribution platforms, with particular attention to the Internet.

Developments in the regulatory framework are also continually monitored for the media segment and their disclosure within the Group is ensured.

Risks associated with Management and “key staff”

The Group’s success depends on the talents of its executive Directors and other members of Management to efficiently manage the Group and the individual business segments.

Editors and TV personalities, too, have a significant role in the titles published and programmes hosted.

The loss of the services of an executive Director, editor, TV personality or other key resource without an appropriate substitute, as well as the difficulty in attracting and retaining new and qualified resources, may impact negatively on the prospects, operations and financial results of the Group.

Risks associated with retaining the value of the brands of the Group titles and TV programmes

The Cairo Communication Group publishes a number of highly successful Italian weeklies, “Settimanale Dipiù” (536,601 copies), “DipiùTV” (335,709 copies), “Settimanale Dipiù e DipiùTV Cucina” (164,151 copies), “TVMia” (154,109 copies) “Diva & Donna” (202,572 copies), “Settimanale Nuovo” (213,816 copies), “F” (136,755 copies) and “Settimanale Giallo” (118,495 copies). Among the monthlies, “Gardenia”, “Bell’Italia”, “For Men Magazine”, “Natural Style” and “Arte” are leaders in their own segment.

The audience figures of the channel’s news and discussion programmes - such as the 8 PM newscast (5.7%), “Otto e mezzo” (5.4%), “Piazza Pulita” (4.8%), “Crozza nel Paese delle Meraviglie” (8%), “Servizio Pubblico” (7.3%), “Anno Uno” (5.5%) “Le invasioni Barbariche” (4.1%), “Coffee Break” (4.9%), “Omnibus” (3.7%), “La Gabbia” (3.4%), “L’aria che tira” (6%), “Bersaglio Mobile” (5%), and “Di martedì” (4.4%) - were positive.

The value of Group brands and TV programmes must be continuously protected by maintaining the current level of quality and innovation.

The Group publishing strategy has always been focused on the quality of its products, driven by the efforts of Management and the editors. Under the agreements with the directors, a significant part of their remuneration is linked to the results of distribution, audience ratings and/or sale of advertising space of the titles and TV programmes.

Risks associated with business with suppliers

A number of the Group’s production processes, particularly magazine printing and use of broadcasting capacity in the TV publishing segment, are outsourced. The outsourcing of production processes requires close cooperation with the suppliers which, on one hand, can result in economic benefits in terms of flexibility, efficiency and cost reduction, but on the other hand, results in the Group’s reliance on these suppliers.

Risks associated with legal and regulatory developments

La7's activity is mainly governed by Legislative Decree no. 177 of 31 July 2005 as amended by Legislative Decree no. 44 of 15 March 2010 (hereinafter Legislative Decree no. 177/05 as amended, also called "Consolidated Act"), which sets the general principles for the provision of audiovisual and radio media services.

With regard to the Automatic Numbering Plan, the numbers currently in use (7 for La7 and 29 for La7d) are those assigned by the Ministry of Economic Development in 2010, under AGCOM resolution 366/2010/CONS. The Resolution had been challenged by Telenorba and other local broadcasters, with partial annulment specifically regarding the assignment of numbers 7-8 and 9 by the Council of State through Ruling 4660/12.

On 21 March 2013, the Communications Authority (AGCOM) unanimously approved the New Automatic Numbering Plan for digital terrestrial television (LCN) by Decision 237/13/CONS. The decision confirmed, for national traditional broadcasters, the assignment of numbers 0-9 of the first block of LCN numbering (see p. 39-40 and 44 of AGCOM Decision no. 237/13/CONS).

Deeming that the New Plan evaded the Council of State's ruling (given that it confirmed assignment to the national traditional broadcasters of numbers 0-9 in the first block of LCN numbering), Telenorba filed an appeal for compliance with ruling n. 4660/12. The appeal was upheld by the Council of State (ruling no. 6021 of 16 December 2013), which declared the New Numbering Plan void (pursuant to Resolution 237/2013) for numbers from 8 to 9, and appointed a special commissioner tasked with verifying the correct assignment of numbers from 8 to 9 within 90 days from the beginning of the proceedings, which started on 24 February 2014. However, since the partial annulment of the previous Plan initially included number 7, on initiation of the procedure, the special commissioner - inappropriately in the opinion of La7 - also referred to number 7, which instead, under the Ruling, is not subject to verification by the Commissioner. AGCOM has in the meantime re-extended the previous Plan (based on current assignments), as also suggested in the State Council's ruling, in order to avoid a regulatory void.

In execution of ruling no. 6021, the Special Commissioner launched a public consultation on an outline provision named "Automatic numbering plan of digital terrestrial free-to-air and pay TV channels, procedures for allocating numbers to providers of audiovisual services authorized to broadcast audiovisual content using digital terrestrial technology and relating conditions of use." Telenorba, All Music and AGCOM have challenged the acts adopted by the Commissioner, lodging enforcement reviews and claims before the State Council (the court of compliance), arguing that the Commissioner had exceeded the requirements of sentence no. 6021 of 2013. Following orders n. 5041, 5127 and 5859 of 2014, under which the Council of State has given the

Commissioner certain regulations to discharge the task, the Commissioner adopted a new outline provision (no. 7 of 2014), accompanied by an explanatory report.

The parties to the proceedings and the Commissioner were heard in personal hearings before the President of the Panel and the Judge-Rapporteur on the assessments made by the Commissioner in the acts recently adopted.

The Commissioner has yet to complete his task (expiry is currently set on 20 May 2015), while the Council of State has yet to rule on the enforcement reviews and claims lodged by Telenorba, All Music and AGCOM.

In the opinion of La7 and its legal advisers, in light of the task discharged by the Commissioner and the orders of the State Council, further assessments by the State Council on number 7 are unlikely to be made, nor will the allocation of this number to La7 be challenged.

Liquidity risk

The Cairo Communication Group is not exposed to liquidity risk, in that on one hand, significant financial resources are held, with a net available positive financial position of Euro 124 million whilst on the other hand, it generates positive results in its traditional segments, and can finance its current operations within the dynamics of its current assets, even in the current market. An analysis of the company's equity structure shows both liquidity, or the ability to maintain financial stability in the short term, and solidity, or the ability to maintain financial stability in the medium/long term.

It is Group policy to invest available cash in on-demand or short-term bank deposits, properly spreading the investments, essentially in banking products, with the prime objective of maintaining a ready liquidity of the said investments. The investment products are selected on the basis of their credit rating, their reliability and the quality of services rendered.

Interest rate and currency risk

The Cairo Communication Group is not exposed to interest rate and currency risk, in that on one hand, there is no loan finance, while on the other hand, Group operations are carried out exclusively in Italy, so all revenue is generated in Italy and main costs are incurred in Euro.

Interest rate risk only affects the yield on available cash.

Movements in the cash flows and the liquidity of Group companies are centrally monitored and managed by Group Treasury in order to guarantee effective and efficient management of financial resources.

Given the limited exposure to both interest rate and FOREX risk, the Group limited use of financial hedging instruments, to hedge currency risk on the acquisition of TV rights from film studios.

Credit risks

The Group is exposed to credit risk, primarily in relation to its advertising sales activities. This risk is however mitigated by the fact that exposure is distributed across a large number of customers and that credit monitoring and control procedures are in place. In terms of concentration, the top 10 customers represent approximately 12% (15% in 2013) of total sales, whilst the top 100 customers represent 54% (58% in 2013).

The persisting uncertainty factors in the short and medium term, along with the resulting credit squeeze, may of course impact negatively the quality of credit and general payment terms.

The publishing segment, on the other hand, presents limited exposure to credit risk as publishing revenue is basically generated by one single party - the Group - while for distribution revenue, the distribution contract provides for an advance payment equal to a highly significant percentage of the estimated sales of each magazine.

The Group's maximum theoretical exposure to credit risks at 31 December 2014 is given by the carrying amount of trade receivables and other recognized current assets totaling Euro 88.3 million (98.4 million at 31 December 2013), and by the nominal amount of guarantees given on third-party debts or commitments as indicated in Note 35 to the consolidated financial statements.

The credit risks associated with cash and cash equivalents, with a maximum theoretical exposure of Euro 149.1 million (Euro 172.9 million at 31 December 2013), are considered irrelevant as they are deposits spread across various banks.

Risks associated with litigation

The notes on "*other information*" (Note 35 to the consolidated financial statements) contain information on a number of cases of litigation. The evaluation of the potential legal and tax liabilities requires the Company to use estimates and assumptions in relation to forecasts made by the Directors, based upon the opinions expressed by the Company's legal and tax advisers, in relation to the probable cost that can be reasonably considered to be incurred. The actual results may vary from these estimates

Report on corporate governance and ownership structure

1 Issuer profile

Cairo Communication has adopted a traditional system of administration and control.

The Shareholders are the corporate body that expresses the will of the shareholders through its resolutions at its meeting. It typically appoints the Chairman.

The Board of Directors has the broadest management powers to achieve corporate objects, within the rules, including self-regulatory rules, that apply. Elected every three years at the Shareholders' Meeting, it appoints one or more Chief Executive Officers and determines their powers, and those of the Chairman.

The Remuneration Committee and the Control and Risk Committee, set up within the Board of Directors, comprise members of the Board of Directors and provide consultative and proposal-making functions to the Board of Directors. The bodies now also include the Related Party Committee, provided for by the procedures for related party transactions adopted in 2010. For the following reasons, it was deemed not to establish an Appointment Committee.

The Board of Statutory Auditors is the body with the functions of overseeing observance of the law and the company bylaws and management control.

The audit process is entrusted to an Audit Firm registered in the relevant professional roll and is the Company's external control body. The Firm checks, throughout the year, that the company's accounts are kept properly and that accounting entries accurately reflect its operation. It is also its responsibility to ensure that the separate and consolidated financial statements match the accounting entries and verifications performed, and that these accounting documents conform to the governing rules.

The duties and methods of operating of these corporate bodies are governed by the law and regulations, by the company bylaws and by the decisions adopted by relevant bodies, in conformity with the regulations set forth in the Corporate Governance Code drawn up by the Corporate Governance Committee of Borsa Italiana S.p.A. in July 2014.

The company bylaws are available at the registered office and in the corporate governance section on the Company's website www.cairocommunication.it.

2 Information on ownership structure (pursuant to art. 123 bis, paragraph 1 of the Consolidated Finance Act – TUF) at 13 March 2015

a) Share capital structure (pursuant to art. 123 bis, paragraph 1, letter a), T.U.F.)

At 13 March 2015, the share capital of Cairo Communication S.p.A. was Euro 4,073,856.80, fully paid and subscribed, and it comprised 78,343,400 shares, with no indication of the nominal amount.

	N° shares	% of share capital	Listed	Rights and obligations
Ordinary shares	78,343,400	100%	Star segment of Borsa Italiana	In accordance with the law and company by-laws

No financial instruments have been issued attributing the right to subscribe to newly-issued shares.

No share incentive plans are foreseen involving share capital increases, even on a freely allocated basis.

b) Restrictions on transfer (pursuant to art. 123 bis, paragraph 1, letter b), T.U.F.)

There are no restrictions on the transfer of securities, except as required by the provisions of representation, legitimization, circulation of the company investment required for securities traded on regulated markets.

c) Significant shareholdings (pursuant to art. 123 bis, paragraph 1, letter c), T.U.F.)

At 13 March 2015, based on the information received pursuant to art. 120 of the T.U.F. and the update of the shareholders' register, the principal shareholders in Cairo Communication S.p.A. were as follows:

Declarer	Direct shareholder	% of ordinary capital	% of voting capital
URBANO ROBERTO CAIRO	U.T. COMMUNICATIONS SpA	44.812%	44.812%
URBANO ROBERTO CAIRO	U.T. BELGIUM HOLDING S.A.	15.710%	15.710%
URBANO ROBERTO CAIRO	URBANO ROBERTO CAIRO	12.387%	12.387%

d) Securities carrying special rights (pursuant to art. 123 bis, paragraph 1, letter d), T.U.F.)

No securities carrying special controlling rights have been issued.

e) Employee shareholdings: voting right procedures (pursuant to art. 123 bis, paragraph 1, letter e), T.U.F.)

There are no employee shareholdings and/or voting rights procedures.

f) Restrictions on voting rights (pursuant to art. 123 bis, paragraph 1, letter f), T.U.F.)

There are no restrictions on voting rights other than those provided by law.

g) Shareholders' agreements (pursuant to art. 123 bis, paragraph 1, letter g), T.U.F.)

No shareholders' agreements are in place pursuant to art. 122 of the T.U.F.

h) Change of control clauses (pursuant to art. 123 bis, paragraph 1, letter h), T.U.F.) and by-law provisions on takeover bids (pursuant to articles 104, paragraph 1 ter, and 104 bis).

The Company and/or its subsidiaries have signed no significant agreements that come into effect, are altered or terminate in the event of a change in the control of the contracting entity.

As explained in the notes to the statements in the consolidated financial statements (Note 28), the bank loan of Euro 25 million, granted by Unicredit S.p.A. in July 2014 to Cairo Network S.r.l. (former Cairo Sport S.r.l.) for the purchase of the rights to use television frequencies, provides for early repayment in the event of a change of control of Cairo Network.

Moreover, the bylaws:

- do not depart from the provisions on the passivity rule provided by art. 104, paragraphs 1 and 2, of the TUF;
- do not provide for the enforcement of the neutralization rule set out in art. 104 bis, paragraphs 2 and 3, of the TUF.

i) Delegations to increase share capital and authorization to acquire and dispose of treasury shares (pursuant to art. 123 bis, paragraph 1, letter m), T.U.F.)

There are no delegations to increase the share capital pursuant to art. 2443 of the Italian Civil Code or to issue equity financial instruments.

At their meeting on 29 April 2014, after revoking a similar resolution adopted on 29 April 2013, the Shareholders approved the proposal to acquire and dispose of treasury shares in accordance with art. 2357 and subsequent articles of the Italian Civil Code, for the purpose of stabilizing the Company share price and sustaining liquidity, and, if deemed necessary by the Board of Directors, through an independent intermediary, of establishing a "shares stock" as provided in Consob regulation 16839/2009. The Board was authorized to acquire treasury shares up to the maximum number permitted by law, for a period of 18 months from the date of authorization, by use of available reserves, including the share premium reserve, as resulting from the last approved annual financial statements. Specifically, the Board of Directors will be authorized to acquire treasury shares on one or more occasions, acquiring shares directly on the market and

through authorized intermediary – in accordance with the procedures provided by art. 144 bis, paragraph 1, letter b of the Issuer Regulation and relevant Instructions – and, in case such operations are carried out, according to accepted market practices, pursuant to the regulations introduced by Consob Resolution No. 16839/2009. Minimum price and maximum acquisition price per share are set at an amount equal to the average official purchase price of the share on Borsa Italiana S.p.A. for the 15 working days preceding the purchase, respectively reduced or increased by 20%. In case such operations are carried out according to accepted market practices under Consob Resolution 16839/2009, the purchase of treasury shares shall be subject to further limits, including price limits, provided therein. The Board was authorized to sell, on one or more occasions, any acquired treasury shares, setting the minimum sale price per share no lower than the minimum price calculated following the criteria adopted for their purchase. Should the treasury shares be sold according to accepted market practices under Consob Resolution 16839/2009, the sale of treasury shares shall be subject to further limits, including price limits, provided therein. A similar authorization for a further period of 18 months will be proposed at the Shareholders' Meeting, whose calling was approved by the meeting of the Board of Directors approving this Report.

In 2014, as part of the share buy-back plans, no treasury shares were sold or purchased. At 31 December 2014, Cairo Communication held a total of n. 779 treasury shares, or 0.001% of the share capital, subject to art. 2357-ter of the Italian Civil Code.

l) Management and coordination

Cairo Communication, though subject to rightful control by U.T. Communication S.p.A. – which is directly controlled by Urbano R. Cairo – is not subject to the management and coordination of such company, nor of any other entity. The Board of Directors of Cairo Communication has come to such conclusion taking account of the absence of further elements (with respect to mere control) that may lean towards the existence of a unitary direction and the circumstance that UT Communication S.p.A. is, de facto, a holding company and has never actually exercised any policy-making functions and/or interference in the management of the Issuer, restricting its activities to the management of its own controlling investment.

It should be noted that information prescribed by art. 123-bis, paragraph 1, **letter (i)** (*“agreements between the Company and the directors, members of the management board or supervisory board providing for indemnity in the event of resignation or unjust dismissal”*) is

found in the section on the Directors' Fees report (Sect. 9), and that there is no information to disclose under art. 123-bis, paragraph 1 **letter (I)**.

3 Compliance (pursuant to art. 123 bis, paragraph 2, letter a), T.U.F.)

The Cairo Communication Group has adopted a Corporate Governance Code for listed companies, amended in July 2014 by the Corporate Governance Committee and promoted by Borsa Italiana, published on the website of Borsa Italiana at <http://www.borsaitaliana.it/comitato-corporate-governance/codice/2014clean.pdf>

No Group company is subject to non-Italian law that would influence the structure of Corporate Governance.

4 Board of Directors

4.1 Appointment and replacement of directors and changes to the bylaws (pursuant to art. 123 bis, paragraph 1, letter h), T.U.F.)

The Board of Directors is appointed by the Shareholders on the basis of lists presented by shareholders pursuant to articles 14 and 15 of the bylaws.

Under the bylaws:

- lists must be filed with the registered office within the 25th day before the date on which the Shareholders' Meeting is called to decide on the appointment of the members of the Board of Directors, and made available to the public at the registered office, on the Company website and in accordance with the procedures provided for by the law and regulations, at least 21 days before the date of the Meeting;
- lists admitted to the voting are those submitted by shareholders who, either individually or jointly with other shareholders, represent at least 2.5% of the shares entitled to vote in the ordinary meeting, or other minimum amount set by Consob, which was set at an amount equal to 2.5% by resolution 19109 of 28 January 2015). Ownership of the minimum stake required for submission of the lists is determined on the basis of the shares recorded in the name of the shareholder on the date the lists are filed with the Company. The relevant prescribed certification may also be submitted subsequent to the filing, provided submission is made within the time limit prescribed for publication of the lists;
- candidates shall appear in the lists in sequential order and shall be in a number no higher than the maximum amount of directors provided under the bylaws (eleven);
- each list must contain candidates possessing the requirements of independence referred to in art. 147-ter, paragraph 4, of the TUF, and further requirements set forth in the Corporate Governance Code of Borsa Italiana S.p.A., in the minimum amount established by the

-
- provisions of law and regulations, taking also into account the share listing segment, and where the number of candidates is equal to or higher than three, the minimum number of candidates of the less represented gender under the applicable law and regulations in force;
- in order to be admitted to the voting, each list must be accompanied by detailed information on the professional and personal qualifications of the candidates (including gender), by the statement on possession of the requirements of independence prescribed by law and by further requirements set forth in the Corporate Governance Code of Borsa Italiana S.p.A., and by indication of the identity of the shareholders who have submitted the lists and total percentage of shares held;
 - for the purposes of the appointment of the directors, account is taken exclusively of lists that have received at least half the votes established by the bylaws for the submission of lists;
 - Should more than one list receive at least half the votes as required by the bylaws for submission of the lists, candidates appointed to the position of director shall be those appearing in the list that has received the highest number of votes, except for the last candidate appearing in the list and the candidate appearing on top of the list that has received the second-highest number of votes that is in no way, even indirectly, connected with the shareholders that have submitted or voted the list that has received the highest number of votes, subject to the possession of the requirements of independence set forth in art. 148, paragraphs 3 and 4 of the TUF and of further requirements set forth in the Corporate Governance Code of Borsa Italiana S.p.A., failing which the appointed candidate, in his/her place, shall be the first candidate appearing in sequential order on the list possessing the foregoing requirements of independence. Should two or more lists reach a tie, the prevailing list shall be the list possessing the largest shareholding or, in the event of a tie, the highest number of shareholders. Should only one list be submitted or should one list obtain a number of votes equal to at least half the votes set out in the bylaws for the submission of a list, all the directors shall be drawn from that list. Should no list obtain the percentage of votes set out in the above paragraph of this article, all directors shall be drawn from the list that has obtained the highest number of votes;
 - according to the above procedure, should the number of directors of the less represented gender be less than the requirements of the laws in force, as many candidates as necessary, elected among those who have come last in the order of preference in the majority list shall be excluded, replacing them with the candidates possessing the necessary gender characteristics drawn from the same list, based on the sequential order of listing. Should this procedure fail to complete the number of directors to elect, the missing directors shall be

immediately elected, in compliance with gender requirements – by the Shareholders' Meeting through a resolution passed by simple majority on the proposal of the attending shareholders;

- should no list be submitted or admitted, the directors shall be elected by the Shareholders' Meeting by relative majority vote, in compliance with the regulations in force on the less represented gender, in the context of the nominations submitted by the shareholders and filed with the registered office at least seven days before the date set for the Shareholders' Meeting on first call, together with the full information referred to in paragraph seven of this article.

Mention must be made, for the purposes set forth in art. 123 bis, paragraph 1, letter (l) of the T.U.F. that, pursuant to art. 21, paragraph 2 of the bylaws, without prejudice to the competence of the Shareholders at their Extraordinary Meeting, who have the authority to decide on the matter, pursuant to art. 2365 of the Italian Civil Code, the Board of Directors is authorized, *inter alia*, to adopt resolutions concerning merger, in the cases set forth in articles 2505 and 2505 *bis* of the Italian Civil Code, capital reduction in the event of shareholder withdrawal, harmonization of the bylaws to mandatory provisions of law, relocation of the registered office to other premises in Italy.

Succession planning

To date, the Board has not adopted any succession plans regarding the executive directors. The Board of Directors is, in any event, the body empowered to prepare and manage early replacement.

4.2 Composition (pursuant to art. 123 bis, paragraph 2, letter d), T.U.F.)

At their meeting on 29 April 2014:

Board of Directors													Control and Risk Committee		Remuneration Committee		Related Party Committee		
Role	Members	Year of birth	Date of first appointment *	From	Until	List **	Exec.	Non exec.	Indep. as per Code	Indep. as per TUF	N. other posts ***	%	(**)	(*)	(**)	(*)	(**)	(*)	
Chairman ◊	Urbano Cairo	1957	09/07/1997	01/01	31/12	M	X	-	-	-	-	6/6	-	-		-	-	-	
CEO	Uberto Fornara	1959	22/04/1999	01/01	31/12	M	X	-	-	-	-	6/6	-	-	-	-	-	-	
Director †	Marco Pompignoli	1967	23/05/2003	01/01	31/12	M	X	-	-	-	-	6/6	-	-	-	-	-	-	
Director	Laura Maria Cairo	1973	29/04/2014	29/04	31/12	M	-	X	-	-	-	4/4							
Director	Roberto Cairo	1965	22/04/1999	01/01	31/12	M	-	X	-	-	-	6/6	-	-	-	-	-	-	
Director	Antonio Magnocavallo	1937	31/05/2000	01/01	31/12	M	-	X	-	-	-	6/6	M	4/4	P	2/2	-	-	
Director	Stefania Petruccioli	1967	29/04/2014	29/04	31/12	M	-	X	X	X	1	4/4			M (from 14/05/14)	N/A	M (from 14/05/14)	N/A	
Director	Roberto Rezzonico	1941	20/11/2000	01/01	31/12	M	-	X	X	X	-	6/6	P	4/4	M	2/2	M (until 14/05/14)	1/1	
Director	Mauro Sala	1944	28/04/2011	01/01	31/12	M	-	X	X	X	-	6/6	M	4/4	-	-	M	1/1	
Director °	Marco Janni	1937	31/05/2000	01/01	31/12	M	-	X	X	X	3	6/6	-	-	M (until 14/05/14)	2/2	P	1/1	
N. of meetings held in 2014:				BoD: 6				CRC: 4				RC: 2				RPC: 1			
Quorum required for the submission of lists by non-controlling interests for the appointment of one or more members: 2.5%																			

Notes:

Regarding the symbols appearing in the "Position" column:

† This symbol indicates the director in charge of the internal control and risk management system.

◊ This symbol indicates the key person in charge of the management of the Issuer (Chief Executive Officer or CEO).

° This symbol indicates the Lead Independent Director (LID).

* Date of first appointment of each director means the date on which each director was appointed for the first time (ever) in the Board of Directors of the Issuer.

** This column indicates M/m depending on whether the director was elected by the majority (M), minority (m) list or BoD (BoD) list.

*** This column indicates number of directorships or statutory auditor positions held in other companies listed on either national or foreign stock exchanges, including finance companies, banks and insurance companies, or of major companies. In the Report on Corporate Governance, positions are shown in full.

(*)This column indicates the participation percentage of directors to the BoD and committee meetings (n. of times present/n. of meetings held during their term, for instance 6/8; 8/8, etc.).

(**).This column indicates the position of the board member in the Committee : "C": Chairman; "M": Member.

Specifically, at their meeting on 29 April 2014:

- the Shareholders appointed for a three-year period, until approval of the financial statements at 31 December 2016, on the basis of the single list presented by the majority shareholder, UT Communications S.p.A., approved with a favourable vote by 75.97% of the share capital, the Board of Directors of the company composed of:
 - o three Executive Directors: the Chairman Urbano Cairo, Uberto Fornara and Marco Pompignoli,
 - o three Non-Executive Directors: Laura Maria Cairo Antonio Magnocavallo and Roberto Cairo and
 - o four independent directors: Marco Janni, Stefania Petruccioli, Mauro Sala and Roberto Rezzonico.

Urbano Cairo is the founder of the Group and has led its growth and development. A graduate in business administration from the Bocconi University, he has significant experience in the publishing and advertising segments. He started working with Fininvest in 1982. He went to work for Publitalia '80 in 1985, where he was appointed Deputy-General Manager in 1990. In 1991 he was appointed as managing director of Mondadori Pubblicità. In December 1995 he founded Cairo Pubblicità, which initiated its distributorship activity for a number of RCS Group magazines. He has therefore been the main leader behind Cairo Communication Group's growth, whose main phases are associated with the 1998 acquisition of the company Telepiù Pubblicità, followed by Cairo TV, dedicated PAY TV distributor, the February 1999 acquisition of Editoriale Giorgio Mondadori, Cairo Communication's listing in 2000, the contract for the exclusive rights for the sale of advertising space on La7 at the end of 2002, the birth of Cairo Editore in 2003 and his subsequent activity in developing successful new publishing initiatives (launch of "For Men Magazine" and "Natural Style" in 2003, "Settimanale Dipiù" in 2004, "Dipiù TV" and "Diva e Donna" in 2005, "TV Mia" in 2008, "Settimanale Nuovo" and weekly magazine "F" in 2012, "Settimanale Giallo" in 2013), and the acquisition of La7 in 2013, which marks the entry in the TV publishing field.

Uberto Fornara is a graduate in business administration from the Bocconi University, and has worked within the Group since its inception, having previously gained significant experience in the publishing segment with Publitalia '80 from 1998 and then in Mondadori Pubblicità, of which he was appointed Director of Customer Service in 1994. He is also CEO of Cairo Pubblicità S.p.A.

Marco Pompignoli was appointed as Chief Financial Officer in June 2000 and is Financial Reporting Manager of Cairo Communication S.p.A. He is a graduate in business administration and has previously worked in leading audit firms, having gained experience in Italy and abroad.

- Laura Maria Cairo, sister of Urbano Cairo. A graduate in law, she has worked with several law firms in Milan and Alessandria, gaining experience in bankruptcy, civil and corporate law; since 2006, she has practised as a lawyer in Alessandria.

Roberto Cairo, Urbano Cairo's brother, is an entrepreneur in real-estate brokerage through Il Metro Immobiliare, with offices in Milan and in Liguria.

Antonio Magnocavallo has been a civil and corporate lawyer in Milan since 1961 and is currently in a partnership (Magnocavallo e Associati). He is presently board member of Fondazione Gruppo Credito Valtellinese and chairman of a number of well-known foundations and associations. He has provided legal assistance and consultancy to the Cairo Communication Group since 1998.

Stefania Petruccioli, a graduate in business administration from the Bocconi University - where she worked until 2004 as an adjunct and assistant professor - chartered accountant, has gained significant experience as a manager and partner in management companies specializing in private equity and venture capital. She is currently found manager in Principia SGR and independent director in the listed company De Longhi S.p.A.

Marco Janni, graduated in civil procedural law in 1960 and was assistant to the chair of civil procedural law at the University of Milan. He is of counsel at the NCTM law firm, which deals with civil, commercial and corporate law. He was a director in large banking groups.

Roberto Rezzonico, chartered accountant, is currently Chairman of the Board of Statutory Auditors or statutory auditor in a number of important industrial groups.

Mauro Sala, chartered accountant and auditor, judge in the Regional Tax Commission of Lombardy from 1996 to 2007, is currently Chairman of the board of statutory auditors, statutory auditor and/or director of a number of companies.

At its meeting approving this Report, the Board established the following general criteria on the maximum number of administrative and control positions in other companies considered compatible with the effective performance of the role of director of the Issuer:

- executive directors may not hold any other executive office, or, in any case, be appointed as statutory auditors in other companies listed on regulated markets, financial companies, banks, insurance companies or major companies, and may hold up to five

-
- non-executive positions in such companies;
 - non-executive directors may hold up to five executive or statutory auditor positions in other companies listed on regulated markets, financial companies, banks, insurance companies or major companies, up to eight non-executive positions in such companies and, in any case, up to a total of fifteen positions;
 - independent directors, without prejudice to the limits set for non-executive directors, which also apply to independent directors, may hold up to eight positions as independent director in other companies listed on regulated markets, financial companies, banks, insurance companies or major companies;

major companies meaning those where at least two of the following parameters have been exceeded: turnover above Euro 500 million, employees above 500 units, balance sheet assets above Euro 50 million, excluding from the calculation companies in which the Company (or its parent) holds a controlling and/or relevant interest (as set out in art. 177 of the Issuers' Regulations).

The directors of Cairo Communication hold no other position in companies listed on regulated markets, financial companies, banks, insurance companies or major companies, except for Stefania Petruccioli, who is director in De Longhi S.p.a., and Marco Janni, who is chairman of CO.MO.I. SIM S.p.A. and of Intesa Lease SEC S.r.l., companies that are not part of the Group to which the Issuer belongs.

Given the directors' vast knowledge of the Company and their wealth of experience in the specific areas of operation of the Cairo Communication Group, as well as the personal and professional background of each member of the Board of Directors, the Board of Directors did not deem it necessary to have them attend (induction program), following appointment and during their term of office, initiatives to provide them with adequate knowledge of the area of operation of the Issuer, of company dynamics and evolution, as well as the relevant regulatory framework.

4.3 Role of the Board of Directors (art. 123 bis, paragraph 2, letter d), T.U.F.)

In 2014, the Board of Directors met 6 times. The Board meetings lasted an average of 2 hours. Six meetings are planned for the current year, two have already been held at 13 March 2015.

To ensure that the Directors be prepared, all the documents and information on the facts taken into consideration by the Board are sent to them via e-mail in reasonable advance (at least two days in advance, a term which, save for urgencies, is usually met) before the date of the meeting. The term was generally met in 2014. In other cases, the Chairman ensured necessary

and appropriate analysis at Board meetings. At Board meetings, the items on the agenda were given the necessary time to allow an effective discussion, while the directors were encouraged to give their own contribution.

The Board of Directors holds the power to (i) purchase, sell or exchange company branches, and companies for amounts in excess of Euro 10 million and (ii) the power to furnish guarantees and endorsements for amounts in excess of Euro 5 million. These powers, or the following powers, cannot be delegated to individual directors:

- a) review and approval of company strategic, business or financial plans or those relating to the Cairo Communication Group, and regular monitoring of their implementation;
- b) Group's system of corporate governance and structure and, specifically, definition of the nature and level of risk consistent with the strategic objectives of the Issuer;
- c) granting or revocation of powers to managing directors;
- d) review and approval of (i) extraordinary transactions, and (ii) transactions involving a potential conflict of interest.

The Board of Directors has also identified the significant transactions which may only be reviewed and approved by the Board.

Such transactions have been identified and defined, starting with the term "transaction" which has been taken to mean:

- i) disposals of intangible assets or property, plant and equipment, even those with no related cost or payment;
- ii) granting of either temporary or permanent rights relating to intangible assets (trademarks, brands, copyrights, databases, etc.);
- iii) provision of work or services;
- iv) granting or obtaining of loans and guarantees (including letters of patronage);
- v) any other action pertaining to property rights.

Significant transactions are those that must be disclosed to the market in accordance with art. 114 of the Consolidated Finance Act, by their nature, procedure or the nature of the counterparty, or those with a value of over Euro 10 million. The signing of advertising sales contracts, the Company's typical activity, is not deemed a significant transaction if it does not involve cost commitments or other financial commitments beyond the granting of a percentage of the revenue generated by the contract to the media owner.

With regard to regulations, these transactions are excluded from the powers conferred on the Directors and as such are subject to prior approval by the Board of Directors. If the Board of Directors cannot meet, for reasons of time pressure or other particular circumstances, the Chairman of the Board of Directors of the Company can carry out the transaction pending the approval of the Board of Directors which would then meet at the earliest possible opportunity.

Significant related party transactions - as described below in paragraph 12 “*Related party transactions*” - are also reserved to the exclusive competence of the Board of Directors of the Company and cannot be delegated.

During the year, the Board:

- evaluated the appropriateness of the organizational, administrative and general accounting structure of the company and of its strategically important subsidiaries (based on their contribution to Group profits and revenue, Cairo Editore S.p.A., La7 S.r.l., Cairo Pubblicità S.p.A. and Cairo Publishing S.r.l.), with particular reference to the internal control and risk management system and the management of conflicts of interest; such valuation was undertaken on the basis of information and evidence gathered through investigation performed by the Control and Risk Committee and through contribution by Company Management and the internal audit manager,
- evaluated the general management trend, taking particular account of information received from the bodies responsible, in addition to comparing results achieved with forecasts.

At its meeting on 14 May 2014, the Board of Directors carried out an evaluation on the size, composition and role of the Board of Directors itself and of its committees, noting that:

- the size of the Board of Directors (ten members, as the bylaws require from five to eleven members) appears adequate, taking into consideration the size and nature of corporate activities;
- the composition of the Board of Directors, considering that the three executive directors, with specific experience in company management, one of whom in finance, are supported by seven non-executive directors, of whom three are lawyers, three are chartered accountants, four of whom independent, is appropriate;
- the role of the Board of Directors and its Committees, as shown in the above table, appears consistent with the size and nature of corporate activities with sufficient delegation of powers granted to the Chairman and to one other executive director.

The Board did not resort to external consultants to perform self-evaluation.

At their Meeting on 29 April 2014, the shareholders resolved to exempt candidates elected to the position of board member from competition restrictions under art. 2390 of the Italian Civil Code for the duration of their term.

4.4 Executive directors

Given the size of the Group and Parent Company, the main executive and managerial powers, except those to (i) purchase or relocate company branches or companies for amounts in excess of Euro 10 million and (ii) to provide guarantees of every kind to third parties and for amounts in excess of Euro 5 million, without prejudice, in any case, to the competences of the Board regarding significant transactions and decisions that cannot be delegated, as identified by the Board and mentioned above, and regarding significant transactions with related parties, are entrusted to the Chairman Urbano Cairo, who is the main person in charge of defining corporate strategies and management (chief executive officer).

Director Uberto Fornara is entrusted with the research and development of activities regarding the sale of advertising space and/or advertising brokerage (except for initiatives requesting commitments and obligations by the Issuer), management of the development of advertising sales, in accordance with the guidelines approved by the Board or by the Chairman, and management of staff and the sales network involved in advertising sales.

Director Marco Pompignoli is responsible for overseeing and supervising the Group's administration, finance and management control functions, which include the power to manage and coordinate the activities of staff working in these areas and to coordinate the activities of the Issuer's legal and tax consultants.

The Chairman is also the controlling shareholder of Cairo Communication. He does not hold the position of director in any other issuer, therefore excluding cases of interlocking directorate.

The executive directors have provided appropriate and regular information every three months to the Board and to the Statutory Auditors. There is no executive committee.

4.5 Other executive directors

There are no other executive directors. None of the non-executive directors i) are CEO or executive chairman in a subsidiary of strategic relevance of the Issuer or ii) hold executive positions in the Issuer or in a subsidiary of strategic relevance or in the Parent.

4.6 Independent directors

Marco Janni, Stefania Petruccioli, Roberto Rezzonico and Mauro Sala are independent directors.

As disclosed to the market on 14 May 2014, soon after their appointment, during the meeting of 14 May 2014, the Board of Directors and Board of Statutory Auditors verified that they met the requirements to be deemed independent directors, pursuant to art.148, paragraph 3, Legislative Decree no. 58 of 24 February 1998, and to the subsequent requirements of the Corporate Governance Code issued by Borsa Italiana S.p.A.

Specifically, with regard to the verification of the independence requirements of Directors Marco Janni, Roberto Rezzonico (directors of the company for over nine years out of the last twelve) and of Mauro Sala (statutory auditor of the company for over nine years out of the last twelve), the Board, given the recurrence of the requirements of independence under art. 148, paragraph 3, of the TUF, and non-recurrence of the most typical cases regarding absence of independence listed in application criterion 3.C.1 of the Corporate Governance Code (letters from a) to h), except for sub e) (under which, as a rule, a director of an issuer who has held this position for over nine years out of the last twelve years is deemed not to be independent¹), given the non-binding nature² - for the purposes of attributing the requirements of independence – of the application criteria, considering in general terms the absence of objective and unambiguous elements proving the existence of particular relations with the Issuer or with subjects linked with the Issuer (such as the majority shareholder, etc.) and, in particular:

¹ It should be noted, however, that the criterion regarding duration in office for over nine years has been regularly disregarded by other listed companies that have adopted the Corporate Governance Code for Listed Companies. See 2013 Annual Report 2013 - 1st report on application of the Corporate Governance Code, prepared by the Corporate Governance Committee of Borsa Italiana S.p.A.

² In 2011, the company had decided to request an opinion on the matter from Prof. Matteo Rescigno, full professor of commercial law at the University of Milan.

-
- (i) the absence of commercial, professional or personal relations between Marco Janni, Roberto Rezzonico and Mauro Sala, on the one side, and the Issuer, and companies belonging to the same group and the controlling partner, on the other, and
 - (ii) the acknowledged professional and moral qualities of the directors in question, renowned professionals with their own businesses;
 - (iii) the minor impact of remuneration decided by the Shareholders to the Board of Directors, which includes remuneration for the participation of certain directors in the committees as per law and the bylaws, on the overall amount of the fees of these directors; in the amounts that Director Marco Pompignoli reports to the Board, as resulting from the information provided by the persons involved,
 - (iv) given also the interest of the Company to still avail itself of the directors' specific experience and in-depth knowledge of the Company's inner workings gained during their term in its various bodies,

confirmed the recurrence of the independence requirement of the foregoing directors.

With regard to the independence of Stefania Petruccioli, following evaluation of the recurrence of the independence requirements under art. 148, paragraph 3, of the TUF, and non-recurrence of the most typical cases regarding absence of independence listed in application criterion 3.C.1 of the Corporate Governance Code (letters from a) to h), considering in general terms the absence of objective and unambiguous elements proving the existence of particular relations with the Issuer or with subjects linked with the Issuer (such as the majority shareholder, etc.), the Board confirmed the existence of the independence requirement of this director.

The Board of Statutory Auditors formally acknowledged and verified the correct application of the criteria adopted by the Board of Directors to evaluate the independence of its members.

The number of independent directors and their function are deemed appropriate in relation to the size of the Board of Directors and the Company's activities, and such as to allow the establishment of the Remuneration, Control and Risk and Related Party Committees (for further information, see § 8 and § 10 and § 12 below).

During the year, the independent directors, in addition to meeting regularly as members of the Related Party Committee, held informal discussions on various occasions without reporting any situation requiring clarification or further discussion.

The Directors who, in the lists for the appointment of the Board, have indicated their eligibility to qualify as independent, have committed to resigning in the event of a subsequent loss of these requirements.

4.7 Lead Independent Director

Given that the Chairman of the Board of Directors is, in actual fact, the main person responsible for the management of the company (chief executive officer) and is also the controlling shareholder of the company, the Board of Directors elected an independent director, Marco Janni, as Lead Independent Director, to whom non-executive directors report, for an increased contribution to the activities and role of the Board. The Lead Independent Director works together with the Chairman to guarantee that the directors receive a complete and timely flow of information. In addition, he has the power to call, whether autonomously or on the request of other directors, appropriate meetings of independent directors for the discussion of issues deemed of being in the interest of the role of the Board of Directors or of the management of the company.

5 Treatment of privileged information

Under the provisions regarding treatment of privileged information, the Company established a register of persons (physical persons, legal entities or associations) who, through their work or professional dealings or the function they carry out on behalf of the Issuer, have regular or occasional access to privileged information (art. 152-bis), which is constantly updated (art. 152-ter). All relevant persons have been fully informed about the establishment of this register.

The Company also enacted the regulations which, in replacement of the self-regulation included in the Code of Conduct on Insider Dealing, places strict disclosure obligations on “relevant persons” of listed companies in relation to share trading carried out by them or persons closely linked to them.

In addition, the Company banned “relevant persons”, with binding effect, from trading in Company shares or related financial instruments, being purchase, sale, subscription or exchange, either directly or through a third party, during the 15 days ahead of any meeting called to approve the financial statements for that period. The exercise of stock options or option rights relating to financial instruments (in any case, currently not in progress) is not included in the ban. The sale of shares derived from stock option plans, including sales carried out as part of the exercise of options, is also exempt. The restrictions, however, do not apply to exceptional situations which are subjectively necessary and appropriately motivated in the interest of the Company.

The Company also has a procedure in place for internal management and the publication of documents and confidential information, particularly price sensitive information governed by the following directives:

- a) Confidential information (Information) is taken to mean every piece of information and news which relates to Cairo Communication S.p.A. (the Company) and its subsidiaries, both direct and indirect (the Cairo Group) which is not in the public domain or is by its nature confidential or of exclusive pertinence to the Cairo Group. Even if expressed as a personal opinion, a piece of information which could affect the price of Group company financial instruments if made public (i.e. price sensitive) is deemed Information.
- b) The management of Information is the sole responsibility of the Company Chairman. In particular, the communication of Information to Consob, the Communications Regulatory Authority (Agcom), Borsa Italiana S.p.A., the media, press agencies, public relations consultants, financial analysts, journalists and any other administrative or regulatory authorities overseeing the activities of the Cairo Group must be carried out exclusively by the Company Chairman directly or occasionally through representatives chosen by him. All Directors and members of the Board of Statutory Auditors must show the utmost discretion in relation to Information acquired while carrying out their duties and must respect Company procedures relating to the publication of Information.
- c) Directors are responsible for the secrecy of documentation given to them in advance of meetings of the Company Board of Directors. In any case, Directors must exercise discretion in relation to Information acquired while performing their duties.
- d) The Chairman takes all measures necessary to ensure that Management and other Cairo Group employees do not transmit Information to third parties if not by law or regulation, and in respect of market best practices, in order to ensure that discretion is exercised in relation to Information acquired while performing their duties.
- e) Should a Director be bound to disclose a piece of Information by the civil or legal authorities, he must communicate this to the Chairman immediately unless otherwise bound by law or the relevant authority.
- f) Further to the provisions relating to the publication of Information, in order to transmit any other information to third parties, or to publish an interview to the media that relates partially or completely to the Cairo Group, Company Directors and Statutory Auditors must obtain specific prior approval of the Chairman.

6 Board of Directors' Committees

The Board of Directors has set up three committees within the Board itself – the Remuneration Committee, the Control and Risk Committee and the Related Party Committee (see section 12 below). The Board decided not to form an Appointment Committee, as it was confirmed that the powers reserved by the Code to said Committee should continue to be carried out by the Board in its entirety (see section § 7 below).

7 Appointment Committee

At its meeting of 14 May 2014, the Board of Directors evaluated the block holdings of the company and the absence of issues reported in the past relating to the sphere of competence of the Appointment Committee, managed efficiently and in compliance with the principles of the Corporate Governance Code directly by the Board of Directors, and decided not to form an Appointment Committee, as it was confirmed that the powers reserved by the Code to said Committee should continue to be carried out by the Board in its entirety.

8 Remuneration Committee

On 14 May 2014, the Board of Directors appointed, for a three-year period, until approval of the financial statements at 31 December 2016, the members of the “Remuneration Committee”, composed of non-executive directors Antonio Magnocavallo, Chairman, Roberto Rezzonico (independent) and Stefania Petruccioli (independent). Roberto Rezzonico and Stefania Petruccioli have adequate experience in the accounting and financial area.

The Remuneration Committee has advisory and proposal-making functions for the Board of Directors, specifically:

- formulation of proposals to the Board of Directors regarding remuneration to executive directors, of other directors with particular responsibilities and of key management personnel;
- to periodically evaluate the adequacy, overall consistency and application of the general policy adopted for remuneration to executive directors, of other directors with particular responsibilities and of key management personnel, using for the latter information furnished by the managing directors, and formulating proposals to the Board of Directors on the matter;

-
- to formulate proposals to the Board of Directors for remuneration to the managing directors and to other directors with particular responsibilities, and to set performance targets related to the variable component of remuneration, by overseeing the application of the decisions adopted by the Board, verifying, in particular, actual achievement of the performance targets;
 - to periodically evaluate the criteria adopted for remuneration to key management personnel, in addition to overseeing the application of any stock option plans (there are no plans underway to date), on the basis of information provided by managing directors, and to provide the Board of Directors with relevant general recommendations.

To ensure correct performance of its duties, the Committee has the power to access all necessary corporate information, in addition to make use of external consultants, in accordance with the terms established by the Board of Directors. The Committee is assisted by a secretary appointed for such purpose (Marco Bisceglia), who records the minutes of the meetings

The functioning of the Remuneration Committee is governed by a policy approved by the Board of Directors. The meetings of the Remuneration Committee were generally not attended by the Chairman of the Board of Statutory Auditors or other auditor delegated by the Chairman; these bodies formulated their opinion on proposals put forth by the Remuneration Committee within the Board of Directors.

The Board of Directors has made financial resources available to the Remuneration Committee for the execution of its functions.

In 2014, the Remuneration Committee met 2 times, for about 1 hour and with all members attending. At least 2 meetings are scheduled this year.

On 14 May 2014, the Board of Directors allocated Euro 20 thousand as annual remuneration to the Remuneration Committee and Euro 2 thousand to the secretary.

9. Directors' Fees

The general policy for directors' fees is illustrated in the Remuneration Report, prepared pursuant to art. 123-ter of the TUF, and will be submitted to the Shareholders at their meeting held to approve the 2014 financial statements, to which reference is made for all the details.

At its meeting on 13 March 2015, the Board of Directors established the general remuneration policy for 2015 (illustrated in Section I of the Remuneration Report) regarding executive

directors, other directors with particular responsibilities and key management personnel, which sets out, among other things, the guidelines for the:

- a) balancing of the fixed and variable components, which envisage ceilings, with regard to strategic objectives and company risk management policy, and ceilings for variable components,
- b) appropriateness of the fixed component for a director's duties, should the performance targets indicated by the Board of Directors not be met and the resulting variable component not be paid,
- c) measurability of performance targets and connection of these targets to the creation of value for shareholders in the medium to long term,

Incentivized remuneration criteria have gradually been introduced for some years now for executive directors and key management personnel, in order to base a sizeable portion of their fees on the achievement of specific performance targets previously set and determined, consistent with the guidelines held in the general remuneration policy adopted by the Board of Directors, as described in the Remuneration Report.

A medium to long-term incentive system (LTI Plan) is currently being assessed with the aim to define it in 2015, in accordance with the principles and limits set out in the policy explained in the Remuneration Report.

The Group has started to study and develop long-term incentivized remuneration criteria (long-term incentive); however, given the crisis affecting the advertising segment and, generally, speaking, the publishing sector for a few years now, a segment that is the core business of the Group, and the resulting instability - based on Nielsen figures in 2012, 2013 and 2014, magazine advertising decreased by 18.4%, 23.9% and 6.5%, respectively, while TV advertising fell by 15.3%, 10.0% and 0.5% - the Group has considered, to date, to defer application of these criteria, owing to the difficulty to set attainable goals to attach to them.

The 2015 remuneration policy envisages the inclusion of claw-back clauses, which allow the company to request the return, in whole or in part, of variable components of remuneration paid (or to withhold sums subject to deferral), determined on the basis of data which has subsequently proven to be manifestly misstated.

Directors' fees for the year 2014 are illustrated in Section II, Part II of the Remuneration Report.

Marco Pompignoli is also the Financial Reporting Manager.

No incentive mechanisms have been introduced for the internal audit manager.

There are no share-based incentive plans in place in favour of executive directors and/or key management personnel.

Remuneration to non-executive directors is not based on company performance. They do not receive any share-based incentive plans.

There are no agreements in place between the Company and the directors for any indemnity in the event of resignation or unjust dismissal, or in the event their employment relationship ceases following a takeover bid.

10 Control and Risk Committee

On 14 May 2014, the Board of Directors appointed for a three-year period (until approval of the financial statements at 31 December 2016) the members of the Control and Risk Committee (former Internal Control Committee), composed of non-executive directors Roberto Rezzonico (independent), Chairman, Mauro Sala (independent) and Antonio Magnocavallo. The Control and Risk Committee, in accordance with the Corporate Governance Code, is currently formed of non-executive directors, the majority of whom are independent. Roberto Rezzonico and Mauro Sala have adequate experience in the accounting and financial area.

The role of the Control and Risk Committee is to provide an early opinion to the Board of Directors in order to discharge the internal control and risk management duties assigned by the Code, in order to:

- i) define the guidelines of the internal control and risk management system, so that the main risks affecting the Company and its subsidiaries are correctly identified and appropriately measured, managed and monitored, determining the level of compatibility of such risks with management of the company that is consistent with the strategic objectives;
- ii) assess, at least annually, the adequacy of the internal control and risk management system with respect to the nature of the Company, its risk profile and its effectiveness;
- iii) appoint an executive director to supervise the operation of the internal audit system;

the Committee also

-
- iv) evaluates, together with the Financial Reporting Manager, after hearing the Audit Firm and the statutory auditors, the proper application of accounting policies, and in the case of groups, overall consistency of the consolidated financial statements;
 - v) expresses an opinion on specific aspects relating to the identification of the main corporate risks;
 - vi) reviews the periodical reports on the evaluation of the internal control and risk management system, and those of particular relevance prepared by the internal audit manager;
 - vii) monitors the independence, adequacy, effectiveness and efficiency of the internal audit function;
 - viii) may request the internal audit function to perform assessments on specific operating areas, providing immediate notice to the Chairman of the Board of Statutory Auditors;
 - ix) reports to the Board of Directors, at least every six months, on the date of the approval of the financial statements and of half-year reports, on their activities carried out and on the appropriateness of the internal control and risk management system.

To ensure correct performance of its duties, the Committee has the power to access all necessary corporate information, in addition to make use of external consultants, in accordance with the terms established by the Board of Directors. During the year, the Committee decided not to resort to external consultants, on the one hand, because it already has the tax, legal and accounting skills needed for the due evaluations and, on the other, because it did not report the existence of specific, significant facts that required their services. The Committee is assisted by a secretary appointed for such purpose (Marco Bisceglia), who records the minutes of the meetings.

In 2014, the Control and Risk Committee met 4 times. Minutes of the meetings, lasting for about 2 hours, were recorded. Four meetings are scheduled this year, one has already been held at 13 March 2015.

The meetings were generally attended, upon invitation, by the Chairman of the Board of Statutory Auditors, by representatives from the Audit Firm, by the Executive Director in charge of the internal control system and by the internal audit manager.

The operation of the Control and Risk Committee is governed by an appropriate regulation approved by the Board of Directors. The Board of Directors has made financial resources available to the Remuneration Committee for the execution of its functions.

During the above activities, and based on the reports received from the internal audit manager, no facts of particular relevance emerged that needed to be reported and the Committee deemed the internal control system as being adequate.

On 14 May 2014, the Board of Directors allocated Euro 20 thousand as annual remuneration to the Control and Risk Committee and Euro 2 thousand to the secretary.

11. Internal control and risk management system

Purposes and objectives

The internal control and risk management system of the Cairo Communication Group consists of a set of rules, procedures and organizational structures, which, through an appropriate process of identification, measurement, management and monitoring of major risks, ensures that financial information is fair, accurate, reliable and timely.

The Board of Directors, assisted by the Control and Risk Committee:

- has defined, in the frame of the definition of the strategic, business and financial plans, the nature and level of risk consistent with the Issuer's strategic objectives;
- has defined the guidelines of the internal control and risk management system, so that the main risks affecting the Company and its subsidiaries are correctly identified and appropriately measured, managed and monitored, determining the level of compatibility of such risks with management of the company that is consistent with the strategic objectives;
- has assessed, at least on an annual basis, the adequacy of the internal control and risk management system with respect to the nature of the Company, its risk profile and its effectiveness.

The Control and Risk Committee analyzed, at least on an annual basis, the plan drafted by the person in charge of internal audit, with the opinion of the Board of Statutory Auditors and the director in charge of the control and risk management system;

The Board of Directors, on proposal of the director in charge of the internal control and risk management system and the favorable opinion of the Control and Risk Committee, after hearing the Board of Statutory Auditors, appoints and revokes the internal audit manager, and sees that

the manager is adequately resourced to perform duties, and defines the manager's fees consistent with corporate policies.

Over the past financial years, the Group has set the policy lines of the internal control system in order to rationalize the overall system by mapping and classifying subjects involved, organize the main reporting flows within the Group and explicate the responsibilities and areas of activities taking place.

The evaluation of the internal control and risk management system is regularly conducted to verify its ability:

- to react to significant situations of risk in a timely manner, ensuring appropriate control mechanisms;
- in terms of corporate processes, to guarantee an appropriate degree of segregation of duties between operating functions and control functions to avoid conflicts of interest in the responsibilities assigned;
- in terms of the operating activities and accounting and administrative activities, to guarantee systems and procedures that assure the accurate recording of company and management events, in addition to the provision of reliable and timely information, both internal and external to the Group;
- to provide for methods to ensure the timely communication of any significant emerging risks and anomalies in control to the appropriate Group Management, and to enable the identification and timely execution of remedies.

The reference model adopted by the Group for the implementation of its internal control system complies with domestic and international best practices and with the indications set by the laws and regulations Cairo Communication is required to comply with as a company listed on a regulated market, such as in particular law 262/2005 and consequent articles 154-bis and 123-bis of the Consolidated Finance Act and Legislative Decree 195/07 ("Transparency Decree") as well as the Corporate Governance Code of Borsa Italiana, to which Cairo Communication conforms.

The system has been designed and implemented following the guidelines issued by a number of sector bodies regarding the activities performed by the Financial Reporting Manager.

Main characteristics of existing risk management and internal control system in relation to the financial reporting process (pursuant to art. 123 bis, paragraph 2, letter b), T.U.F.)

Stages of the existing system of risk management and internal control system in relation to the financial reporting process

The risk management and internal control system in relation to the Group's financial information rests basically on the application and monitoring of relevant corporate procedures for the purposes of the preparation and disclosure of financial information.

Specifically, the internal control system is split up into the following stages:

- a) Identification and evaluation of risks related to financial information;
- b) Identification of controls upon identification of risks;
- c) Evaluation of controls upon identification of risks.

The evaluation procedures and instruments used by the Group are periodically subject to review processes aimed at the verification of their suitability and function as compared to the corporate reality, which is by its very nature mutable. Therefore, where possible, an information flow has been put in place in order to maintain, update and improve system quality.

- a) Risk identification and evaluation for financial reporting: the identification of both the scope of the entries and their “significant” processes in terms of potential impact on financial reporting, and of the risks consequent to any missed control objectives, comes about by way of a quantitative analysis of the financial statement items and a qualitative evaluation of the processes.

The quantitative analysis, aimed at the identification of the relevant entries, is performed through the application of the concept of “materiality” to the combined items in the trial balance of the Cairo Communication Group. The materiality threshold was determined as a fixed percentage in compliance with the indications in article 2621 of the Italian Civil Code (replaced by Law no. 262 of 28 December 2005).

Once the significant accounts have been identified through the account-processes combination, the significant processes are then distinguished.

The qualitative analysis, through the evaluation of the significance of the business processes and of their level of complexity, integrates the quantitative analysis,

determining the inclusion or the exclusion of the processes in regard to the scope of reference.

For each process identified as significant, there are then also identified specific process risks, which in the event of their occurrence, would compromise the achievement of the objectives connected to the system: that is to say, those of accuracy, reliability, credibility and timeliness of financial reporting.

The financial reporting manager reviews the definition of the scope of reference at least annually and also, each and every time that elements, which might change the analysis performed in a significant manner, are manifested.

- b) Identification of the controls corresponding to the identified risks: the identification of the controls necessary for the mitigation of the ascertained risks is performed associating the risks identified to the relative control objectives, meaning the group of objectives that the financial reporting control system intends on achieving in order to ensure a true and correct representation.

The controls established have been formalized inside a specific matrix (“Matrix of risks and controls”).

- c) Evaluation of the controls corresponding to the identified risks: the evaluation of the administrative and accounting control system is to be performed at least annually.

The valuation of the suitability of the actual application of the controls is performed through specific verification activities, aimed at guaranteeing the programming and implementation of the identified controls, upon indication and coordination on the part of the financial reporting manager.

Based on the results of the verification work, the financial reporting manager, with the aid of the support staff, defines a remedy plan so as to correct any deficiencies that may impact negatively on the effectiveness of the risk management and internal control system in relation to financial reporting.

At least annually, the financial reporting manager reports to the Control and Risk Committee and the Board of Statutory Auditors and communicates with the company supervisory boards, regarding the methods with which the suitability evaluation and the application of the controls and administrative - accounting procedures have been conducted, then expressing his own evaluation on the suitability of the administrative - accounting control system.

Roles and functions

The subjects involved in the internal control and risk management system, each with their own specific role, are:

1. the Board of Directors, which guides and assesses the adequacy of the system, identifying within the system:
 - (i) the director in charge of the formation and maintenance of an effective internal control and risk management system (the “director in charge of the internal control and risk management system”), and
 - (ii) the Control and Risk Committee, in charge of assisting, through appropriate preparatory work, the assessments and decisions of the Board of Directors regarding the internal control and risk management system, as well as those regarding the approval of periodical financial reports;
2. The internal audit manager, in charge of verifying that the internal control and risk management system is working properly and adequately;
3. other roles and functions with specific tasks regarding internal control and risk management,
4. the Board of Auditors, which monitors the effectiveness of the internal control and risk management system.

Art. 154-bis of the Consolidated Finance Act provides for the presence, in the corporate organization of listed companies, of the “Financial Reporting Manager”, appointed by the Board of Directors in concert with the Managing Director. The Manager is responsible for planning, implementing and approving the accounting and administrative control model, and for assessing its application, issuing a certificate on half-year, annual and consolidated financial statements.

The Manager is also responsible for preparing adequate administrative and accounting procedures for the formation of the separate and consolidated financial statements, and for providing subsidiaries, considered as significant entities for the preparation of the Group’s consolidated financial reporting, with instructions on how to perform an appropriate evaluation of their accounting control system.

Overall evaluation of the appropriateness of the internal control and risk management system

Based on the information and evidence gathered following preliminary analysis conducted by the Control and Risk Committee, supported by Management and by the internal audit manager,

Board of Directors deems the internal control and risk management system to be, as a whole, appropriate for allowing, with reasonable assurance, achievement of the Company's objectives. The evaluation, as it refers to the overall internal control system, is by nature limited. While well-structured and in operation, the internal control system is designed only to guarantee accomplishment of corporate objectives with “reasonable assurance”.

11.1 Executive director in charge of the internal control and risk management system

Marco Pompignoli, executive director, is responsible for overseeing the operation of the internal control and risk management system. During the year, he was responsible for:

- identifying main corporate risks (strategic, operational, financial and compliance), taking account of the nature of the operations carried out by the company and its subsidiaries, to submit them for the review of the Board of Directors,
- executing the policies as identified by the Board of Directors, providing for the planning, realization and management of the internal control system, constantly monitoring the overall appropriateness, effectiveness and efficiency,
- adapting the system to the dynamics of the Group’s operating conditions and to the legal and regulatory framework.

The director in charge of the internal control and risk management system has requested the internal audit manager to perform assessments on the main areas of operations and on compliance with company rules and procedures in the execution of business operations, informing the Chairman of the Control and Risk Committee and the Chairman of the Board of Auditors and reporting to the Control and Risk Committee on the findings.

11.2 Internal audit manager

The role of internal audit manager is carried out by an external professional, Ezio Micheli, appointed at the end of 2007 on the proposal made by the executive director responsible for the internal control system and taking account of the opinion of the Control and Risk Committee, who reports to the Control and Risk Committee and to the Board of Statutory Auditors.

The Board of Directors has assigned the internal audit manager the responsibilities foreseen by the Corporate Governance Code and has defined his remuneration, in line with corporate policy, providing him with the appropriate means to fulfill his duties.

The Board of Directors has verified that this person possesses the necessary professional and independence requirements to perform such function. In particular, he is not in charge of any operating area and is not subordinate to any person in charge of operating areas, including administration and finance.

The internal audit manager has been allowed direct access to all useful information for the performance of his duties and has reported on his activities to the Control and Risk Committee and to the Board of Statutory Auditors and to the executive director responsible for overseeing the operation of the internal control system.

During the year, the activities of the internal audit manager mainly focused on verifying the updating and implementation process of corporate procedures. He is a member of the Supervisory Board pursuant to Legislative Decree 231/2001, as indicated in section 11.3 below.

The internal audit manager, also assisted by unrelated external consultants, experts in these areas, made available to the Company:

- verified on a continuous basis (not having reported specific needs) the operation and adequacy of the internal control and risk management system through an audit plan, based on the structured analysis and ranking of key risks and the reliability of information systems, including the accounting systems;
- regularly referred to the Control and Risk Committee, during the meetings of the Committee, also attended by the Chairman of the Board of Statutory Auditors and the director in charge of the internal control and risk management system, providing appropriate information on the tasks performed, on risk management procedures, and compliance with defined plans for risk mitigation, as well as an opinion on the adequacy of the internal control and risk management system;
- assessed, as part of the audit plan, the reliability of information systems, including accounting systems.

11.3 Organizational Model pursuant to Legislative Decree 231/2001

On 31 March 2008, the Board of Directors adopted a Model for organization, management and control pursuant to Legislative Decree 231/2001 (Organizational Model), thereby providing itself with a set of principles of conduct and procedures to comply with the requirements of Legislative Decree 231/2001, both in terms of the prevention of crime and illicit acts, and in

terms of control measures to ensure implementation of the Model itself. The Model was updated by the Board of Directors, on proposal of the Supervisory Board, in 2009 and 2012, following regulatory changes; the latest cases introduced in the category of offenses (mainly including “bribery among private individuals”, environmental crimes and crimes of association, incitement to make false statements, crimes against industry and self-laundering) are currently being discussed with a view to their introduction in the Model. A similar model was also adopted on 13 November 2008 by the subsidiaries Cairo Pubblicità S.p.A. and Cairo Editore S.p.A. (later updated, consistent with the Organizational Model of Cairo Communication S.p.A.) and on 18 December 2013 by the subsidiary La7 S.r.l.

The Organizational Model adopted is made up of a set of principles, rules and organizational hierarchies relating to the management and control of corporate activities and is presented in an explanatory document which:

- identifies the activities in which crimes could be committed;
- provides for specific rules directed at planning the formation and performance of corporate decisions relating to crimes to be prevented;
- identifies methods for the management of financial resources directed at crime prevention;
- provides for the provision of information to the body deputized with oversight of the operation and observation of the models (Supervisory Board);
- introduces a disciplinary system directed at punishing failure to respect measures identified by the Organization Model.

The Organizational Model adopted provides for the presence of a corporate body responsible for assuming the functions of a control body (Supervisory Board) with autonomous responsibilities for the supervision, control and initiative related to the Model, composed of three members who must be selected from persons having proven abilities in inspection, management, administration and legal matters, and who must also possess minimum requirements of professionalism and integrity.

Specifically, the Supervisory Board verifies that the company has an appropriate Organizational Model in place and ensures it is effectively carried out, certifying its own effectiveness whilst carrying out its functions, ensuring the progressive update, thus guaranteeing constant process of adjustment to the above-mentioned operating and/or organizational principles.

In 2014, the members of the Supervisory Board of Cairo Communication S.p.A. were Ezio Micheli, internal audit manager, Giacomo Leone and Marco Bisceglia, Chairman.

11.4 Audit Firm

At their meeting on 28 April 2011, on proposal by the Board of Statutory Auditors, the Shareholders conferred the audit assignment for the 2011-2019 nine-year period to KPMG S.p.A., approving the relevant fee.

11.5 Financial Reporting Manager

The Board of Directors appointed Marco Pompignoli, Chief Financial Officer of the Cairo Communication Group, as the Financial Reporting Manager. He has the appropriate professional requirements (graduate in business administration, previously working for a major audit firm, gaining significant experience in Italy and abroad, and a certified accountant registered in Forlì).

Marco Pompignoli, as board member of the company, is provided with executive and management powers to oversee the administration, finance and management control functions of the Group to which the Issuer belongs.

11.6 Coordination among parties in the internal control and risk management system

Regarding coordination among the various parties involved in the internal control and risk management system (Board of Directors, director in charge of the internal control and risk management system, Control and Risk Committee, internal audit manager, Financial Reporting Manager, Supervisory Body and Board of Statutory Auditors), the meetings of the Control and Risk Committee are generally attended also by the:

- Chairman of the Board of Statutory Auditors,
- partner or senior partner of the Audit Firm,
- director in charge of the internal control and risk management system, Marco Pompignoli, who is also the Financial Reporting Manager,
- the internal audit manager, Ezio Micheli, who is also member of the Supervisory Body.

Furthermore, the Board of Statutory Auditors and the Supervisory Board schedule a specific joint annual meeting also attended by the director in charge of the internal control and risk management system and the partner or senior partner of the Audit Firm to take stock of

activities performed during the year, to plan those for the following year and to jointly discuss any issues of common interest from their respective areas of competence.

In any event, during the year, information is continually exchanged between the Board of Statutory Auditors and the Supervisory Board.

12 Related party transactions

Consob, through Resolution no. 17221 of 12 March 2010, amended through subsequent Resolution no. 17389 of 23 June 2010, adopted, pursuant to art. 2391-bis of the Italian Civil Code, and to articles 113-ter, 114, 115 and 154-ter of the TUF, the regulations regarding provisions pertaining to related party transactions, to which management bodies of issuers of widely distributed securities must comply (the “**Regulation**”).

At its meeting on 11 November 2010, the Board of Directors of Cairo Communication S.p.A., on the favourable opinion of the independent directors, adopted the procedures for related party transactions (the “*Procedures*”), for the purpose of guaranteeing “*substantial and procedural transparency and fairness of related party transactions*” carried out by the Company directly or through its subsidiaries, establishing a Related Party Committee.

Pursuant to the Regulation, Cairo Communication is considered a “small company”, since its assets and its revenue shown, shown in the last approved financial statements (31 December 2013), are lower than Euro 500 million, amounting respectively to approximately Euro 301 million and to approximately Euro 249 million. For such companies, the Regulation provides for the possibility to “apply to transactions of greater importance, as a waiver to art. 8, a procedure identified pursuant to art. 7 of the Regulation” (transactions of lesser importance).

The procedures adopted by the Company, available on www.cairocommunication.it in the *Corporate Governance* section, to which reference is made for complete details, have also identified:

- a) the definition of related parties and transactions;
- b) roles and responsibilities;
- c) transactions of greater importance, being those in which at least one of the ratios of significance (equivalent value relevance ratio, assets and liabilities relevance ratio) set out in the Regulation are higher than the threshold of 5%, or of 2.5% for transactions whose purpose is the disposal of intangible assets of strategic importance;
- d) the exemptions provided in the Regulation and opted by the Company, mainly transactions of smaller amounts (Euro 150,000), remuneration plans pursuant to art. 114-bis of the TUF

(which comply with the obligations regarding transparency and substantial and procedural correctness provided by the temporary provisions in force), regular transactions concluded under market-equivalent or standard conditions and the transactions with and between subsidiaries and/or associates;

- e) the procedures regarding the preliminary proceedings and approval of related party transactions and the regulations in cases where the company examines or approves transactions with subsidiaries;
- f) the procedures and timing adopted to provide information on the transactions, and the related documentation, to the directors or independent directors who express opinions on related party transactions, as well as to the management and independent advisors, before their approval, during and after their execution.

Related party transactions of greater importance are reserved to the exclusive competence of the Board of Directors and may not be delegated. The execution of such transactions, as well as those of lesser importance, is subject to a non-binding opinion of the Related Party Committee, or of other bodies indicated in the procedures.

In the event one or more transactions are approved, notwithstanding a negative opinion expressed by the Committee and/or other bodies, the Company draws up and makes available to the public at its main registered office within 15 days from the close of each quarter of the financial year, a document containing indication of the counterparty, of the object and counter value of such transactions approved in the quarter of reference, as well as the reasons why that opinion has not been shared. Within the same time, this opinion is made available to the public in attachment to the above document or on its website www.cairocommunication.it.

Regarding transactions of greater importance falling under the competence of the Shareholders, in the event the resolution proposal is approved, notwithstanding contrary advice by the Related Party Committee (or by other bodies), the transaction is not carried out if the majority of unrelated shareholders votes against the transaction, provided the unrelated shareholders attending the Meeting represent at least 10% of the share capital with voting right (whitewash mechanism). For such purpose, in the resolution proposal, the Board adds a provision that specifies that the effectiveness of the transaction is subject to the foregoing majority.

Related party transactions must comply with transparency and substantial and procedural correctness criteria and are executed in the exclusive interest of the Company:

- substantial correctness means correctness of the transaction from an economic point of view when, for instance, the transfer price of goods is in line with market prices and,

more in general, when the transaction has not been influenced by the related party relationship, or at least said relationship has not determined the acceptance of conditions that are unjustifiably penalizing for the Company;

- procedural correctness means compliance with procedures aimed at ensuring the substantial correctness of the transaction and, therefore, observance of the rules through which it is at least potentially ensured that related party transactions do not determine any unjustified prejudice to the reasons of the Company and its investors.

At the Board of Directors' meeting called to resolve on such related party transactions, directors who have even a potential or indirect interest in the transaction must provide prompt and exhaustive information in person to the Board on the existence of such interest and on the circumstances thereof, leaving the meeting at the moment of the resolution. Should the directors' presence be needed to maintain the necessary quorum, the Board may decide, upon the unanimous decision of the attendants, for the directors not to leave the meeting.

The Regulation also provides for a series of obligations to inform the public on transactions of greater importance, as well as for those of lesser importance, at least every quarter in the latter case.

The Committee for the approval of related party transactions (hereinafter, the “**Related Party Committee**”), regardless of the importance, is appointed by the Board of Directors and can be composed of three members:

- (i) in the event at least three independent directors have been elected to the Board of Directors, the members of the Committee are all independent directors;
- (ii) otherwise than under the case indicated in the above point (i), its members are non-executive directors, the majority of whom are independent. In such case, the Committee may coincide with the Control and Risk Committee.

On 14 May 2014, the Board of Directors appointed the members of the Related Party Committee, composed of the three independent directors Marco Janni, Chairman, Stefania Petruccioli, and Mauro Sala, and allocated Euro 20 thousand as annual remuneration to the Related Party Committee. The Committee is assisted by a secretary appointed for such purpose (Marco Bisceglia), to whom the Board of Directors allocated Euro 2 thousand as annual remuneration.

The Committee is required to perform all the tasks indicated in the Regulation and in the procedures. Specifically, its task is to release a motivated opinion on the interest of the

Company (or, if the case, of its subsidiaries) on the execution of related party transactions and on the convenience and substantial correctness of conditions thereto. If required by the nature, extent and characteristics of the transaction, the Related Party Committee may also be assisted by one or more independent experts of its choice, whose fees are paid by the Company, through the acquisition of specific reports and/or fairness and/or legal opinions.

The Board of Directors may decide on remuneration for special responsibilities pursuant to art. 2389, paragraph 3, of the Italian Civil Code, to the Committee members for each transaction it is required to express an opinion on.

13 Appointment of the Board of Statutory Auditors

Under art. 26 of the company bylaws, the Board of Statutory Auditors is appointed on the basis of lists submitted by the shareholders containing a maximum of five candidates.

Under the bylaws:

- members of the Board of Statutory Auditors are appointed on the basis of lists that must be filed with the registered office of the Company within the 25th day before the Shareholders' Meeting called to decide on the appointment of the members of the Board of Statutory Auditors, made available to the public at the registered office, on www.cairocommunication.it and in accordance with the other procedures provided by law and regulations, at least 21 days before the date of the Meeting. Upon expiry of the time limit of 25 days prior to the Meeting, in the event only one list has been filed, or lists submitted by shareholders who are connected, pursuant to applicable provisions, lists may be submitted until the fourth day (as set forth in the bylaws) subsequent to such date. In this event, the foregoing 2.5% threshold (or other minimum amount set by prevailing laws) is reduced by half;
- the lists consist of two sections: one for candidates to the position of standing auditor, and the other for candidates to the position of alternate auditor, and where the number of candidates is equal to or higher than three, they must ensure minimum gender representation required by the laws and regulations in force at the time;
- lists admitted to the voting are those submitted by shareholders who, either individually or jointly with other shareholders, represent at least 2.5% of the shares entitled to vote in the ordinary meeting, or other minimum amount set by Consob, which was set at an amount equal to 2.5% by resolution 19109 of 28 January 2015). Ownership of the

minimum stake is determined on the basis of the shares recorded in the name of the shareholder on the date the lists are filed with the Company; candidates may appear in one list only, under penalty of ineligibility; candidates holding the position of statutory auditor in 5 (five) other listed companies (excluding their subsidiaries, although listed) or holding a number of positions exceeding the cumulative limit prescribed by law and by Consob, or failing to possess the requirements of integrity and professionalism established by prevailing laws, shall not appear in the lists. Each list shall be accompanied by a) information regarding the identity of the shareholders who have submitted the list, indicating total percentage of shares held, and by prescribed certification on ownership of the stake, which may be submitted also subsequent to filing, provided within the time limit set for publication of the lists; b) a statement of the shareholders other than those who hold, also jointly, a controlling or relative majority interest, declaring they have no relationship of connection, pursuant to applicable provisions; c) detailed information regarding the personal and professional qualifications of the candidates (including gender), and a statement with which each candidate accepts nomination and attests, under own responsibility, that there are no reasons for ineligibility or incompatibility with the position, and confirms possession of the requirements prescribed by law and the bylaws for the respective positions;

- the chairman of the Board of Statutory Auditors shall be the candidate indicated on top of the list that has received the second-highest number of votes. The bylaws do not provide for the appointment of more than one minority statutory auditor, nor do they provide for the possibility of drawing a number of alternate auditors from the minority list to replace the minority member greater than the minimum required by Consob;
- should two or more lists reach a tie, the prevailing list shall be the list possessing the largest shareholding or, in the event of a tie, the highest number of shareholders;
- should only one list be submitted, the three standing auditors and two alternate auditors shall be drawn from this list, in the sequential order in which they appear, in which case the Chairman of the board of statutory auditors shall be the candidate appearing on top of the list;
- according to the above procedure, should the composition of the board of statutory auditors fail to comply with gender balance required by law or regulations currently in force, the necessary replacements shall be made based on the sequential order of listing of candidates;

-
- should no list be submitted or admitted, the board of statutory auditors and its Chairman shall be appointed by the Shareholders' Meeting by relative majority vote, in compliance with the laws and regulations in force on gender balance.

14 Composition and operation of the Board of Statutory Auditors (pursuant to art. 123 bis, paragraph 2, letter d), T.U.F.)

At their meeting on 29 April 2014 the Shareholders appointed the Board of Statutory Auditors for a three-year period, until the approval of the financial statements at 31 December 2016, on the basis of a single list submitted by the major shareholder, UT Communication S.p.A. approved with the favourable vote of 76.34% of the share capital. The Board of Statutory Auditors comprises three standing auditors, Marco Moroni, Chairman, Maria Pia Maspes and Marco Giuliani, and two alternate auditors, Emilio Fano and Enrico Tamborini, who have certified that they know of no relative cause of ineligibility or incompatibility, and that they meet the requirements for the position under current legislation and the bylaws, specifically, the requirements of independence provided by art. 148, paragraph 3 of the TUF, and the requirements of independence provided by industry regulations if applicable on account of business activities performed. During the year, Mario Danti terminated his position as alternate auditor, his term having expired with the approval of the financial statements at 31 December 2014.

Board of Statutory Auditors									
Post	Members	Year of birth	Date of first appointment*	From	Until	List (M/m)**	Independence as per Code	*** (%)	Number of other posts ****
Chairman	Marco Moroni	1963	05/05/2008	01/01	31/12	M	X	100	15
Standing auditor	Marco Giuliani	1959	28/04/2011	01/01	31/12	M	X	100	14
Standing auditor	Maria Pia Maspes	1970	30/01/2006	01/01	31/12	M	X	100	13
Alternate auditor	Emilio Fano	1954	29/04/2014	29/04	31/12	M	X	n/a	n/a
Alternate auditor	Enrico Tamborini	1967	28/04/2011	01/01	31/12	M	X	n/a	n/a
Quorum required for the submission of lists at previous appointment: 2.5%									
No. of meetings held during 2014: 4									

NOTES:

* *Date of first appointment of each statutory auditor means the date on which each statutory auditor was appointed for the first time (ever) in the Board of Statutory Auditors of the Issuer.*

** *This column indicates M/m depending on whether the statutory auditor was elected by the majority (M) or minority (m) list*

*** *This column indicates the participation percentage of statutory auditors to the BoA meetings (n. of times present/n. of meetings held during their term, for instance 6/8; 8/8, etc.).*

**** *This column indicates number of directorships or statutory auditor positions held, pursuant to art. 148-bis TUF and related implementation provisions contained in Consob's Issuers' Regulations. The complete list of appointments is published by Consob on its website pursuant to Art. 144-quinquiesdecies of the Issuer Regulations of Consob.*

In 2014, 4 meetings were held each lasting approximately 2 hours. Five meetings are scheduled for the current year, one has already been held.

The Board of Statutory Auditors assessed the independence of its members following their appointment. For its assessments, it based itself, among other criteria, also on those prescribed by the Corporate Governance Code regarding independence of directors. In any event, auditors who, either or on their own behalf or of third parties, may have an interest in a specific transaction involving the Issuer, shall promptly and fully inform the other auditors and the Chairman of the Board of Directors as to the nature, terms, origin and extent of their interest.

The Board of Statutory Auditors also oversaw the independence of the Audit Firm, verifying the respect of relevant regulatory requirements in terms of the nature and overall service provided other than the audit services provided to the Company and its subsidiaries by the same Audit Firm and the entities forming part of its network.

In the performance of its duties, the Board of Statutory Auditors coordinated its activities with the internal audit manager and with the Control and Risk Committee, also with the attendance of its Chairman or other statutory auditor delegated to the meetings of the Control and Risk Committee. Auditors who, either or on their own behalf or of third parties, has an interest in a specific transaction involving the Issuer, shall promptly and fully inform the other auditors and the Chairman of the Board of Directors as to the nature, terms, origin and extent of their interest.

Given the vast knowledge of the Company accumulated by the statutory auditors and their wealth of experience in the specific areas of operation of the Cairo Communication Group, as well as the specific personal and professional background of each member of the Board of Statutory Auditors, it was not deemed necessary to have them attend (induction program), following appointment and during their term of office, initiatives to provide them with adequate knowledge of the area of operation of the Issuer, of company dynamics and evolution, as well as the relevant regulatory framework.

15 Investor Relations

Cairo Communication has set up an appropriate section in its website, which is easy to find and easily accessible, in which all important company information of interest to shareholders is made available.

To put a communication flow in place with the general body of shareholders, also taking account of the size of the Company and Group, an appropriate “investor relations” function has been set up, managed by Mario Cargnelutti, who is supported by top management, particularly in relation to dealings with institutional investors.

16 Shareholders’ Meetings

The functioning of the Shareholders’ Meeting, its main powers, shareholders’ rights and terms of their exercise are those prescribed by the applicable provisions of law and regulations.

Multiple-voting shares or increased voting rights are not envisaged.

The By-laws contain no provisions that reserve shareholders the authorization of specific actions taken by the directors. As already mentioned, pursuant to art. 21, paragraph 2 of the bylaws, without prejudice to the competence of the Shareholders at their Extraordinary Meeting, who have the authority to decide on the matter, pursuant to art. 2365 of the Italian Civil Code, the Board of Directors is authorized, inter alia, to adopt resolutions concerning merger, in the cases set forth in articles 2505 and 2505 bis of the Italian Civil Code, capital reduction in the event of shareholder withdrawal, harmonization of the bylaws to mandatory provisions of law, relocation of the registered office to other premises in Italy.

Shareholders’ voting rights and representation at meetings is governed by the provisions of law and regulations. Art. 12 of the bylaws states as follows: “*Shareholders entitled to vote at meetings and their representation is governed by the provisions of law and regulations. In particular, shareholders authorized to cast a vote may send notice by electronic means of the proxies issued pursuant to the prevailing laws, by accessing a specific section on the*

Company's website according to the procedures to be indicated in the notice of call of shareholders' meetings."

Voting by correspondence, e-voting and/or voting using audiovisual links has not been established.

Given the number of attendants at Company ordinary and extraordinary shareholders' meetings, which has never posed any risk to the rights of expression of any member in relation to matters discussed, no regulations relating to the orderly and functional operation of the Meetings have been proposed for the approval of the Shareholders.

Shareholders' Meetings are an opportunity for information regarding the Issuer to be communicated to shareholders, as part of the code of practice relating to privileged information. In particular, at Shareholders' Meetings, the Board of Directors reports on activities completed and planned, and ensures that shareholders have appropriate information on all topics required in order to make decisions at the meeting with full knowledge of the facts. All members of the Board of Directors attended the Meeting held on 29 April 2014.

In order to meet this objective, the Board of Directors makes available to shareholders all company information they deem relevant, in a timely manner, in accordance with the code of practice relating to privileged information. For such purpose, a dedicated section of the Company website has been set up where this type of information is displayed, with particular detail on attendance at Shareholders' Meetings, the exercise of voting rights and documentation relating to items on the agenda.

No proposals were made at the Shareholders' Meeting to vote on items on which a proposal had not been made in advance by the Board of Directors.

At the last Shareholders' Meeting, the President (or other member) of the Remuneration Committee was not required to report to the shareholders on the manner of exercising the functions of the Committee, which are appropriately explained in the Remuneration Report and Corporate Governance Report.

In 2014, no significant changes were reported in the market capitalization of the Issuer's shares or in the composition of its corporate structure.

17 Further corporate governance practices

There are no corporate governance practices further to the ones mentioned above applied by the Company, aside from the legal or regulatory requirements.

18 Changes after year end

There were no changes in the Corporate Governance structure after year end.

Treasury shares

Movements in treasury shares are disclosed in Note 19 to the separate financial statements of the Parent Company.

Stock Options

Cairo Communication has no current stock option plans at this time.

Shares held by directors, statutory auditors and general managers

Shares held directly by Directors, Statutory Auditors and General Managers are illustrated in the Remuneration Report prepared pursuant to art. 123-ter of the TUF.

Other information

Research and development activities

There are no research and development activities to report having a significant effect on the performance of the Company or the Group.

Human resources

By the nature of the activities it carries out, human resources form a critical factor for the success of the Group. The evaluation of staff, the development of their abilities and the recognition of their achievements and responsibilities are the principles which govern personnel management, from the selection phase, which is facilitated by the high degree of the Group's visibility and its ability to attract personnel.

Staff turnover during 2014 and its composition at 31 December 2014 can be analyzed as follows:

Description	31/12/2013	Recruitments	Terminations	Advancements	31/12/2014
<i>Open-ended contracts</i>	698	25	(16)	4	711
Senior managers	24	1	(2)	0	23
Managers	82	2	(2)	1	83
Employees	371	21	(9)	1	384
Journalists and freelance	221	1	(3)	2	221
<i>Fixed-term contracts</i>	39	81	(90)	(4)	26
Senior managers	0	1	0	0	1
Managers	0	0	0	0	0
Employees	31	58	(75)	(2)	12
Journalists and freelance	8	22	(15)	(2)	13
Grand total	737	106	(106)	0	737

Personnel can also be analyzed by average age, sex, education and seniority:

	Senior managers	Managers	Employees	Journalists and freelance
Men (number)	24	50	196	102
Women (number)	0	33	199	133
Average age	50	49	44	32
Seniority	12	13	12	9
Open-ended contracts	23	83	384	221
Fixed-term contracts	1	0	11	14
Graduates	20	36	86	111
Diploma holders	4	46	285	122
Middle school graduates	0	1	24	2

Most of the employees (438) work in the TV segment, followed (225) by the magazine and book publishing segment. The advertising segment employs 74 people and draws on a sales force of approximately 100 agents (direct and indirect) who are coordinated by senior sales managers and staff who, together with their staff, also ensure coordination with the editors and the promotion of special initiatives.

The Group is committed to pursue health and safety objectives at the workplace. There were no accidents in the workplace or charges for occupational diseases during the year.

Environment

The Cairo Communication Group has outsourced its production processes. There are no major environmental aspects which could affect the financial position or results of operations of the company.

Privacy

Regarding privacy regulations, Cairo Communication and Group companies update the Personal Data Policy Document, which establishes treatment followed, resources subject to security measures, risks, rules (physical and logical measures, and security organizational measures) and the relating training plan.

In previous years, technical and organizational measures and methods had been put in place - integrating those already operational where necessary – regarding storage of the identifying details of system administrators and verification of work performed, in order to guarantee the monitoring of their work.

EVENTS AFTER THE REPORTING PERIOD AND BUSINESS OUTLOOK

In January 2015, Cairo Network and EI Towers S.p.A. entered into the agreements for the realization and subsequent long-term technical management in full service mode (hospitality, service and maintenance, use of broadcasting infrastructure, etc.) of the Mux, operating on TV frequencies for digital terrestrial broadcasting systems. The company acquired the rights of use in 2014, in the frame of the tender procedure opened by the Ministry of Economic Development.

The agreements with EI Towers provide, among other things, for:

- a transitional phase, which will see the realization and start-up of the Mux and the initial operations, which will run from the date the agreements were signed to 31 December 2017, and an operational phase of the Mux lasting 17 years (from 2018 to 2034);
- the right to free withdrawal of Cairo Network starting from 1 January 2025;
- guaranteed coverage at full performance of at least 94% of the population, in line with national Muxs with greater coverage;
- consideration to EIT:
 - o during the transitional phase (2015-2017), amounting to a total of Euro 11.5 million for the full three-year period;
 - o at full performance (starting from 2018), amounting to Euro 16.3 million per year.

These amounts include compensation for the availability of the transmitters;

-
- an annual consideration from El Towers to Cairo Network, starting from 2018, ranging between Euro 0 up to Euro 4 million, in the event that the available bandwidth on the Mux is not fully used by Cairo Network

With the acquisition and realization of the Mux, the Cairo Communication Group will start activities as a network operator and have at its autonomous disposal a broadcasting capacity of about 22.4 Mbps versus the current 7.2 Mbps leased, which can be used to broadcast the La7 and La7d channels from 2017, to broadcast new channels if the Company were to launch any, or even lease them to third parties as early as 2016.

In 2014, despite facing a challenging relevant market, the Cairo Communication Group:

- strengthened the results of the cost rationalization measures in the TV publishing segment (La7) implemented during the eight months of activity in 2013, succeeding in achieving also in 2014 a positive gross operating profit (EBITDA) of Euro 9 million, while in the January-December twelve-month period of 2013, gross operating loss of La7 had amounted to Euro 25.4 million;
- strengthened the results of “F”, “Settimanale Nuovo” and “Settimanale Giallo”, confirmed the high circulation levels of the other publications, and worked on improving the levels of efficiency reached in containing costs in the magazine publishing segment (production, publishing and distribution);
- kept advertising revenue levels high, despite the general market trend;
- achieved highly positive results in its traditional segments (magazine publishing and advertising), despite the general economic and financial context and relevant market trend;
- took part with the subsidiary Cairo Network in the tender procedure opened by the Ministry of Economic Development for the assignment of rights to use TV frequencies for digital terrestrial broadcasting systems, submitting its binding bid and winning the rights to use a lot of frequencies ("Mux") for a period of 20 years.

In 2015, the Cairo Communication Group will continue to develop its traditional businesses (magazine publishing and advertising). Despite the current economic and competitive context, and given the high quality of the publications and the media under concession, the Group considers it a feasible target to continue to achieve positive operating results.

Looking at the TV publishing segment, in 2015, the Group will continue to work on strengthening the results of the rationalization and cost-curbing measures achieved in 2013 and 2014.

However, the evolution of the general economic situation could affect the full achievement of these targets.

For the Board of Directors
Chairman Urbano Cairo

Dear Shareholders,

at the meeting held on 13 March 2015, the Board of Directors resolved to submit the financial statements as at and for the year ended 31 December 2014 to the approval of the Shareholders and to propose the distribution of a dividend of 0.27 Euro per share, inclusive of tax.

Shareholders are invited:

- to approve the financial statements as at and for the year ended 31 December 2014;
- to resolve on the proposal to distribute to shareholders a dividend of 0.27 Euro per share, inclusive of tax, with the exception of treasury shares held the evening prior to the record date pursuant to art. 83-*terdecies* of Legislative Decree 58/1998:
 - distributing profit for the year of Euro 10,585,866
 - drawing the difference from the share premium reserve.

If approved by the Shareholders, the dividend of Euro 0.27 per share will be made payable from 13 May 2015 (record date pursuant to art. 83-*terdecies* Legislative Decree 58/1998: 12 May 2015), prior to detachment of coupon n. 9 on 11 May 2015.

For the Board of Directors
Chairman Urbano Cairo



CAIRO COMMUNICATION

Consolidated Financial Statements and notes thereto

Consolidated income statement for the year ended 31 December 2014

€ thousands	Notes	31 December 2014	31 December 2013
Revenue	1	240.266	249.514
Other revenue and income	2	11.927	7.985
Change in finished products	3	(28)	(61)
Raw materials, consumables and supplies	4	(24.589)	(28.287)
Services	5	(113.827)	(134.121)
Non-recurring costs for services	10	0	(1.917)
Use of third-party assets	6	(22.811)	(17.828)
Personnel expense	7	(60.634)	(48.789)
Amortization, depreciation, provisions and impairment losses	8	(5.221)	(5.606)
Other operating costs	9	(2.121)	(1.728)
Operating profit		22.962	19.162
Income / (loss) on investments	11	(2)	699
Non-recurring income from acquisition of La7 S.r.l.	10	0	57.066
Net financial income	12	1.829	2.901
Pre-tax profit		24.789	79.828
Income tax	13	(973)	(5.620)
Profit from continuing operations		23.816	74.208
Loss from discontinued operations	14	(1)	(6)
Profit for the year		23.815	74.202
- Owners of the parent		23.791	74.194
- Non-controlling interests - discontinued operations		0	0
- Non-controlling interests - continuing operations		24	8
		23.815	74.202
Earnings per share (€)			
- Earnings per share - continuing and discontinued operations	16	0,304	0,949
- Earnings per share - continuing operations	16	0,304	0,949

Consolidated statement of comprehensive income for the year ended 31 December 2014

		31 December 2014	31 December 2013
Profit for the year		23.815	74.202
<i>Other non-reclassifiable items of the comprehensive income statement</i>			
Actuarial gains (losses) from defined benefit plans	21	(1.367)	(510)
Tax effect		376	140
Total comprehensive income for the year		22.824	73.832
- Owners of the parent		22.800	73.824
- Non-controlling interests - discontinued operations		0	0
- Non-controlling interests - continuing operations		24	8
		22.824	73.832

Consolidated statement of financial position at 31 December 2014

€ thousands			
Assets	Notes	31 December 2014	31 December 2013
Property, plant and equipment	17	3.069	2.829
Intangible assets	18	56.871	12.986
Investments	19	62	72
Non-current financial assets	19	1.113	483
Deferred tax assets	20	3.983	4.589
Total non-current assets		65.098	20.959
Inventories	21	3.296	4.104
Trade receivables	22	79.957	90.065
Receivables from parents	32	6.539	5.583
Other receivables and other current assets	23	8.430	8.369
Cash and cash equivalents	25	149.061	172.915
Total current assets		247.283	281.036
Total assets		312.381	301.995
Equity and liabilities		31 December 2014	31 December 2013
Share capital		4.027	4.027
Share premium reserve		42.361	45.452
Prior-year earnings (losses) and other reserves		56.132	985
Profit for the year		23.791	74.194
Equity attributable to the owners of the parent		126.311	124.658
Non-controlling interests share capital and reserves		36	12
Total shareholders' equity	26	126.347	124.670
Non-current financial payables and liabilities	28	20.000	0
Post-employment benefits	27	13.398	11.832
Provisions for risks and charges	29	30.343	34.982
Total non-current liabilities		63.741	46.814
Current financial payables and liabilities	30	5.000	0
Trade payables	31	87.884	105.926
Payables to parents	32	156	11
Tax liabilities	33	5.487	3.752
Other current liabilities	34	23.766	20.822
Total current liabilities		122.293	130.511
Total liabilities		186.034	177.325
Total equity and liabilities		312.381	301.995

Consolidated statements of cash flows

€ thousands	31 December 2014	31 December 2013
CASH AND CASH EQUIVALENTS	172.915	61.234
OPERATING ACTIVITIES		
Profit for the year	23.815	74.202
Non-recurring income from the acquisition of La7 S.r.l. (Note 10)	0	(57.066)
Amortization and depreciation	3.609	1.628
Income / (loss) on investments	2	(699)
Net financial income	(1.829)	(2.901)
Income tax	973	5.620
Change in post-employment benefits	1.439	108
Change in provisions for risks and charges	(4.639)	527
Cash flow from operating activities before changes in working capital	23.370	21.419
(Increase) decrease in trade and other receivables	10.047	9.893
Increase (decrease) in trade and other payables	(15.098)	(14.922)
(Increase) decrease in inventories	808	1.310
TOTAL CASH FLOW FROM OPERATING ACTIVITIES	19.127	17.700
Income tax paid	557	(4.529)
Financial expense paid	(512)	(27)
TOTAL NET CASH FROM OPERATING ACTIVITIES (A)	19.172	13.144
INVESTING ACTIVITIES		
(Acquisition) disposal net of PPE and intangible assets	(47.734)	(5.394)
Cash and cash equivalents acquired net of purchase price of La7 S.r.l. (*)	0	109.199
Interest and financial income received	2.468	3.391
Net increase in other non-current assets	(622)	1.235
NET CASH USED IN INVESTING ACTIVITIES (B)	(45.888)	108.431
FINANCING ACTIVITIES		
Dividends paid	(21.152)	(10.905)
(Acquisition) disposal of treasury shares	0	1.382
Re-measurement of defined benefit plans inclusive of tax effect	(991)	(370)
Increase in financial payables	25.000	0
Other changes in equity	5	(1)
NET CASH USED IN FINANCING ACTIVITIES (C)	2.862	(9.894)
CASH FLOW OF THE YEAR (A)+(B)+(C)	(23.854)	111.681
NET CASH AND CASH EQUIVALENTS CLOSING BALANCE	149.061	172.915

(*) Main items of the consolidation of La7 S.r.l. at 30 April 2013:

Other non-current assets	(1.013)
Inventories	(1.557)
Trade and other current receivables	(59.707)
Trade and other current payables	75.053
Provisions for risks and charges	32.176
Post-employment benefits	7.181
Non-recurring income from the acquisition of La7 S.r.l.	57.066
Cash and cash equivalents acquired net of purchase price of La7 S.r.l.	109.199

Statement of changes in consolidated equity

	Share capital	Share premium reserve	Prior-year earnings (losses) and other reserves	Available-for-sale financial assets	Interim dividend	Profit for the year	Equity attributable to owners of the parent	Non-controlling interests share capital and reserves	Total
€ thousands									
Balance at 31 December 2011	4.074	49.586	(1.683)	0	(11.696)	23.446	63.727	3	63.730
Effects from application of amended IAS 19			(2)			2	0		0
Balance at 1 January 2012	4.074	49.586	(1.685)	0	(11.696)	23.448	63.727	3	63.730
Allocation of profit			23.448			(23.448)	0		0
Dividend distribution		(4.134)	(19.257)		11.696		(11.695)		(11.695)
Interim dividend					(10.126)		(10.126)		(10.126)
Purchase of treasury shares			(214)				(214)		(214)
Other movements			(5)				(5)		(5)
Total comprehensive income for the year						18.663	18.663	1	18.664
Balance at 31 December 2012	4.074	45.452	2.287	0	(10.126)	18.663	60.350	4	60.354
Effects from application of amended IAS 19			(94)			94	0		0
Balance at 1 January 2013	4.074	45.452	2.193	0	(10.126)	18.757	60.350	4	60.354
Allocation of profit			18.757			(18.757)	0		0
Dividend distribution			(21.031)		10.126		(10.905)		(10.905)
Disposal of treasury shares			1.382				1.382		1.382
Actuarial gains (losses) from defined benefit plans			(370)			370	0		0
Other movements			7				7		7
Total comprehensive income for the year						73.824	73.824	8	73.832
Balance at 31 December 2013	4.074	45.452	938	0	0	74.194	124.658	12	124.670
Allocation of profit			74.194			(74.194)	0		0
Dividend distribution		(4.390)	(16.762)				(21.152)		(21.152)
Actuarial gains (losses) from defined benefit plans			(991)			991	0		0
Other movements		5					5		5
Total comprehensive income for the year						22.800	22.800	24	22.824
Balance at 31 December 2014	4.074	41.067	57.379	0	0	23.791	126.311	36	126.347

Consolidated income statement pursuant to Consob Resolution no. 15519 of 27 July 2006

€ thousands

	31 December 2014	related parties (*)	% of total	31 December 2013	related parties	% of total
Revenue	240.266	165	0,1%	249.514	176	0,1%
Other revenue and income	11.927	51	0,4%	7.985	42	0,5%
Change in finished products	(28)			(61)		
Raw materials, consumables and supplies	(24.589)			(28.287)		
Services	(113.827)	(2.111)	1,9%	(134.121)	(2.120)	1,6%
Non-recurring costs for services	0			(1.917)		
Use of third-party assets	(22.811)			(17.828)		
Personnel expense	(60.634)			(48.789)		
Amortization, depreciation, provisions and impairment losses	(5.221)			(5.606)		
Other operating costs	(2.121)			(1.728)		
Operating profit	22.962			19.162		
Income / (loss) on investments	(2)			699		
Non-recurring income from acquisition of La7 S.r.l.	0			57.066		
Net financial income	1.829			2.901		
Pre-tax profit	24.789			79.828		
Income tax	(973)			(5.620)		
Profit from continuing operations	23.816			74.208		
Loss from discontinued operations	(1)			(6)		
Profit for the year	23.815			74.202		

(*) Related party transactions are analyzed in Note 36

Consolidated statement of financial position pursuant to Consob Resolution no. 15519 of 27 July

2006

€ thousands							
Assets	31 December 2014	related parties (*)	% of total	31 December 2013	related parties (*)	% of total	
Property, plant and equipment	3.069			2.829			
Intangible assets	56.871			12.986			
Investments	62			72			
Non-current financial assets	1.113			483			
Deferred tax assets	3.983			4.589			
Total non-current assets	65.098			20.959			
Inventories	3.296			4.104			
Trade receivables	79.957	471	0,6%	90.065	445	0,5%	
Receivables from parents	6.539	6.539	100,0%	5.583	5.583	100,0%	
Other receivables and other current assets	8.430	47	0,6%	8.369	47	0,6%	
Cash and cash equivalents	149.061			172.915			
Total current assets	247.283			281.036			
Total assets	312.381			301.995			
Equity and liabilities	31 December 2014			31 December 2013			
Share capital	4.027			4.027			
Share premium reserve	42.361			45.452			
Prior-year earnings (losses)	56.132			985			
Profit for the year	23.791			74.194			
Equity attributable to the owners of the parent	126.311			124.658			
Non-controlling interests share capital and reserves	36			12			
Total equity	126.347			124.670			
Non-current financial payables and liabilities	20.000			0			
Post-employment benefits	13.398			11.832			
Provisions for risks and charges	30.343			34.982			
Total non-current liabilities	63.741			46.814			
Current financial payables and liabilities	5.000			0			
Trade payables	87.884	1.428	1,6%	105.926	181	0,2%	
Payables to parents	156	156	100,0%	11	11	100,0%	
Tax liabilities	5.487			3.752			
Other current liabilities	23.766			20.822			
Total current liabilities	122.293			130.511			
Total liabilities	186.034			177.325			
Total equity and liabilities	312.381			301.995			

(*) Related party transactions are analyzed in Note 36

Consolidated statement of cash flows pursuant to Consob Resolution no. 15519 of 27 July 2006

€ thousands	31 December 2014	related parties	31 December 2013	related parties
CASH AND CASH EQUIVALENTS	172.915		61.234	
OPERATING ACTIVITIES				
Profit for the year	23.815	(1.895)	74.202	(1.902)
Non-recurring income from the acquisition of La7 S.r.l.	0		(57.066)	
Amortization and depreciation	3.609		1.628	
Income / (loss) on investments	2		(699)	
Net financial income	(1.829)		(2.901)	
Income tax	973		5.620	
Change in post-employment benefits	1.439		108	
Change in provisions for risks and charges	(4.639)		527	
Cash flow from operating activities before changes in working capital	23.370	(1.895)	21.419	(1.902)
(Increase) decrease in trade and other receivables	10.047	(982)	9.893	(817)
Increase (decrease) in trade and other payables	(15.098)	1.392	(14.922)	(1.120)
(Increase) decrease in inventories	808		1.310	
TOTAL CASH FLOW FROM OPERATING ACTIVITIES	19.127	(1.485)	17.700	(3.839)
Income tax paid	557		(4.529)	
Financial expense paid	(512)		(27)	
TOTAL NET CASH FROM OPERATING ACTIVITIES (A)	19.172	(1.485)	13.144	(3.839)
INVESTING ACTIVITIES				
(Acquisition) disposal net of PPE and intangible assets	(47.734)		(5.394)	
Cash and cash equivalents acquired net of purchase price of La7 S.r.l.	0		109.199	
Interest and financial income received	2.468		3.391	
Net increase in other non-current assets	(622)		1.235	
NET CASH USED IN INVESTING ACTIVITIES (B)	(45.888)	0	108.431	0
FINANCING ACTIVITIES				
Dividends paid	(21.152)		(10.905)	
(Acquisition) disposal of treasury shares	0		1.382	
Re-measurement of defined benefit plans inclusive of tax effect	(991)		(370)	
Increase in financial payables	25.000			
Other changes in equity	5		(1)	
NET CASH USED IN FINANCING ACTIVITIES (C)	2.862	0	(9.894)	0
CASH FLOW OF THE YEAR (A)+(B)+(C)	(23.854)	(1.485)	111.681	(3.839)
NET CASH AND CASH EQUIVALENTS CLOSING BALANCE	149.061		172.915	

NOTES TO THE CONSOLIDATED FINANCIAL STATEMENTS AS AT AND FOR THE YEAR ENDED 31 DECEMBER 2014

Main activities

Cairo Communication S.p.A. (the Parent) is a joint-stock company listed in the Milan Company Register. The Cairo Communication Group operates as a publisher of magazines and books (Cairo Editore – and its division Editoriale Giorgio Mondadori – and Cairo Publishing), as a television editor (La7), as a multimedia advertising broker selling advertising time and space on television, in print media and in stadiums (Cairo Communication and Cairo Pubblicità), as a publisher of electronic content (Il Trovatore) and network operator (Cairo Network S.r.l.).

As explained in the Directors' Report, in 2014 the subsidiary Cairo Network S.r.l. (former Cairo Sport S.r.l.) took part in the tender procedure opened by the Ministry of Economic Development for the assignment of rights to use TV frequencies for digital terrestrial broadcasting systems, submitting its binding bid and winning the rights to use a lot of frequencies ("Mux") for a period of 20 years. In January 2015, Cairo Network and EI Towers S.p.A. entered into the agreements for the realization and subsequent long-term technical management in full service mode (hospitality, service and maintenance, use of broadcasting infrastructure, etc.) of the Mux. With the acquisition and realization of the Mux, the Cairo Communication Group started operations as a network operator.

The registered offices are at 56 Via Tucidide, Milan, home also to the administrative offices, the advertising brokerage services and Il Trovatore and Cairo Network. The publishing business is managed at Cairo Editore, at 55 Corso Magenta, Milan. The publishing business of La7 is managed mainly in Rome at the registered offices and the TV studios of La7 S.r.l. at 229 Via della Pineta Sacchetti and 32 Via Novaro, respectively.

Figures are shown in thousands of Euro.

Basis of preparation

Structure, form and content of the consolidated financial statements

The consolidated financial statements at 31 December 2014 have been prepared in accordance with IFRS issued by the International Accounting Standard Board ("IASB") and endorsed by the European Union, as well as with the provisions arising from art. 9 of Legislative Decree no. 38/2005. The term IFRS is used to mean all the international accounting standards ("IAS") and all the interpretations of the International Financial Reporting Interpretations Committee ("IFRIC"), formerly the Standing Interpretations Committee ("SIC").

The **consolidated income statement** is presented by nature, highlighting interim operating results and pre-tax results, and in order to allow a better measure of ordinary operating management performance.

Furthermore, cost and revenue components deriving from events or transactions which, by their nature or size are considered non-recurring, are also separately identified in the financial statements and the notes in accordance with the definition of non-recurring events and transactions held in Consob Communication No. 6064293 of 28 July 2006.

The economic effects of discontinued operations are shown in a single line of the income statement entitled “profit/loss from discontinued operations”, under IFRS 5.

The **consolidated statement of comprehensive income** also reflects the “changes arising from transactions with non-owners”- separately showing the relevant tax effects, that is:

- profit and loss that could be directly recognized in equity (for instance actuarial gains and losses from the measurement of defined benefit plans);
- the effects of the measurements of derivative instruments hedging future cash flows;
- the effects of the measurements of available-for-sale financial assets;
- the effects arising from any change in accounting standards.

The consolidated statement of comprehensive income presents the items relating to the amounts of the components of other comprehensive income for the period by nature and grouped into those which, in accordance with the provisions of other IAS/IFRS:

- will not be subsequently reclassified to profit (loss) for the year;
- will be subsequently reclassified to profit (loss) for the year, when certain conditions are met.

In 2013, the economic effects of the acquisition of the equity interest in La7 S.r.l. were shown in the income statement under "non-recurring income from the acquisition of La7 S.r.l.", following completion of the Purchase Price Allocation process, in accordance with IFRS 3 and explained in Note 10.

The **consolidated statement of financial position** presents separately assets and liabilities divided in current and non-current, indicating, on two separate lines, “Assets held for sale” and “Liabilities associated with discontinued operations”, in accordance with IFRS 5. Specifically, an asset or a liability is classified as current when it satisfies one of the following criteria:

- it is expected to be realized or settled or it is expected to be sold or utilized in the normal operating cycle of the company;
- it is held principally to be traded;
- it is expected to be realized or settled within 12 months of the reporting date.

Otherwise, the asset or liability is classified as non-current.

The **consolidated statements of cash flows** have been prepared applying the indirect method in which operating performance is adjusted to reflect transactions of a non-monetary nature, for whatever deferral or accrual of previous or future operating receipts or payments and for revenue or cost components connected to cash flows arising from investing or financing activities. Income and expense relating to medium or long-term financial operations and those relating to hedging instruments, and dividends paid are included in financing activities.

The **statement of changes in consolidated equity** shows the variations in equity relating to:

- allocation of profit for the year;
 - amounts relating to transactions with owners (purchase and sale of treasury shares);
- and separately income and expense defined as “*changes arising from transactions with non-owners*”, also shown in the consolidated statement of comprehensive income.

Furthermore in order to comply with Consob Resolution No. 15519 of 27 July 2006 relating to financial statements schedules, specific additional consolidated income statement, consolidated statement of financial position and consolidated statement of cash flows have been added highlighting significant related party transactions in order not to compromise the overall readability of financial statements schedules.

The consolidated financial statements are prepared on a going concern basis. The Cairo Communication Group believes that even in the presence of a difficult economic and financial situation, significant uncertainties do not exist (as defined by paragraphs 25 and 26 of IAS 1) on the Company’s ability to continue as a going concern, given both the profitability outlook of Group companies and the Company’s financial position.

The main accounting policies adopted are unchanged versus those used last year, and are explained below.

Basis and scope of consolidation

The scope of consolidation, based on the full method, includes consolidated subsidiaries (control is defined as the power of the Parent to determine the financial and operational policies of the company in order to derive benefits from its operations) and, based on the single line method, consolidated associates, over which significant influence is exercised.

The consolidated financial statements at 31 December 2014 include the financial statements of the Parent Cairo Communication S.p.A. and the following direct or indirect subsidiaries and associates:

Company	Head office	Share capital at 31/12/14	% of investment	Reporting date	Business	Consolidation method
Cairo Communication S.p.A.	Milan	4,074		31/12	Advertising	Full
Cairo Editore S.p.A.	Milan	1,043	99.95	31/12	Publishing	Full
Diellesei S.r.l. in liquidation	Milan	10	60	31/12	In liquidation	Full re assets and liabilities (*)
La 7 S.r.l.	Rome	1,020	100	31/12	TV publishing	Full from 30 April 2013
Cairo Pubblicità S.p.A.	Milan	2,818	100	31/12	Advertising	Full
Cairo Network S.r.l. (former Cairo Sport S.r.l.)	Milan	5,500	100	31/12	Network operator	Full
Cairo Publishing S.r.l.	Milan	10	100	31/12	Publishing	Full
Il Trovatore S.r.l.	Milan	25	80	31/12	Internet	Full
Edizioni Anabasi S.r.l.	Milan	10	99.95	31/12	Publishing	Full

(*) the income statement is consolidated on a single line basis in profit/(loss) from discontinued operations

In 2014, the subsidiary Cairo Network S.r.l. (former Cairo Sport S.r.l.) was consolidated. Its financial statements had not been previously consolidated, as the company was not significant because it was not operational.

There were no other changes to the scope of consolidation from the consolidated financial statements for the year ended 31 December 2013.

The financial results of subsidiaries acquired or sold during the year are included in the consolidated income statement from the actual acquisition date until the actual date of sale. Where necessary, adjustments to subsidiary financial statements are made in order to harmonize them with the Group accounting policies.

The full consolidation method has been used for the consolidation of subsidiary financial statements, assuming the total of assets, liabilities, income and expense of individual companies, regardless of the share owned, eliminating the carrying amount of the Parent investment against the subsidiary's equity.

Non-controlling interests in the net assets of consolidated subsidiaries are disclosed separately from equity attributable to owners of the parent. This stake is calculated on the basis of the percentage stake of the fair value of the asset or liability on the original purchase date and subsequent changes in equity after such date.

Unrealized gains and losses, provided they are not minor, deriving from transactions between companies included in the scope of consolidation, are eliminated, as are all significant transactions which give rise to intra-Group receivables and payables, income and expense. These adjustments, like other consolidation adjustments, where applicable, take account of the related deferred tax effect.

Dividends distributed by consolidated companies are eliminated from the income statement and added to prior-year profits if and to the extent they were paid out of such profit.

Business combinations

The acquisition of subsidiaries is recognized using the acquisition method. The acquisition price is calculated by the sum of current values, at the exchange date, of the assets acquired, liabilities assumed, financial instruments issued by the Group in exchange for the control of the acquired company.

The subsidiary's assets, liabilities and identifiable contingent liabilities that meet the conditions of IFRS 3 are recognized at their current value on the acquisition date.

Goodwill arising from the purchase is recognized as an intangible asset and is initially measured at cost, corresponding to that portion of the acquisition price paid by the Group exceeding the carrying amount of the recognized assets, liabilities and identifiable contingent liabilities.

The positive difference between assets and liabilities measured at fair value at the acquisition date and the price paid is recognized in the consolidated income statement as non-recurring income. It may be subject to further adjustment within twelve months from the date of acquisition.

Equity attributable to non-controlling interests can be measured at fair value or in proportion to the net assets recognized for the acquired company, at the acquisition date. The measurement method is chosen based on type of transaction.

Non-controlling interests, investments in inactive subsidiaries and investments in subsidiaries of small value are measured using the cost at the subscription method, reflecting any impairment losses.

Investments

Associates

Associates are those over which the Group can exercise significant influence through participation in decisions regarding financial and operating policies, but holds neither control nor joint control.

The financial results, assets and liabilities of associates are consolidated using the equity method.

Using this method, investments in associates are recognized in the statement of financial position at cost, adjusted for changes subsequent to the acquisition of the net assets of associates, net of any impairment losses on individual investments. Any losses exceeding the Group share therein are not recognized, unless the Group has a commitment relating to loss coverage. The excess of acquisition cost over the Group share of carrying amount of assets, liabilities and identifiable contingent liabilities of the associate at the acquisition date is recognized as goodwill. Every year, goodwill is tested for impairment.

With regard to transactions between Group companies and associates, unrealized profits and losses are eliminated in a proportion equal to the Group investment in the associate, except when unrealized losses are evidence of an impairment loss on the business acquired.

Goodwill

Goodwill arising from the acquisition of a subsidiary corresponds to that portion of the acquisition price paid by the Group that exceeds the Group share of the fair value of the assets, liabilities and identifiable

contingent liabilities of a subsidiary, at the acquisition date. Goodwill is recognized as an intangible asset with an indefinite life and is not amortized. It is reviewed annually to identify any impairment loss. Impairment losses are recognized directly in profit and loss and are not subsequently reversed. In the absence of a standard or a specific interpretation on the subject, in the case of the acquisition of a non-controlling interest in an existing subsidiary, up to 31 December 2009, the difference between the cost of acquisition and the carrying amount of the assets and liabilities acquired is recognized as goodwill. Goodwill arising from acquisitions carried out before transition to IFRS is maintained at the amounts derived from the application of Italian GAAP at that date and is tested for impairment from that date.

Translation of foreign currency items

Transactions in foreign currency are initially recognized at the exchange rate in force on the transaction date. Monetary assets and liabilities denominated in foreign currency are translated at the exchange rate in force at year end.

Non-monetary items valued at historical cost in foreign currency are converted at the exchange rate ruling on the transaction date. Non-monetary items recognized at fair value in foreign currency are converted at the exchange rate ruling on the fair value measurement date.

If a designated fair value hedging relationship has been set up between a hedging instrument and an element being hedged in foreign currency, the accounting treatment applied is the same as for hedges, as explained under “Hedging instruments”.

Revenue and cost recognition

Revenue and cost and income and expense are recognized on an accruals basis, specifically:

- Revenue is recognized based on the probability with which the company will enjoy the economic benefits and in the extent to which the amount can be reliably determined. Revenue is stated net of any adjustments.
- Advertising revenue is recognized at the moment the advertisement is broadcast or published. Revenue from publications is recognized at the date of publication, net of reasonably estimated returns.
- Revenue from the sale of magazine subscriptions is recognized on the basis of the magazines published and distributed during the period.
- Pre-publication and launch costs are recognized in profit and loss when incurred.
- Interest income and expense are recognized on an accruals basis.
- Dividends are recognized when the right of the shareholders to receive the payment is established.
- Costs incurred on behalf of third parties are recharged against the cost to which they relate.

Taxes

Taxes for the year correspond to the sum of current and deferred taxes.

Current taxes are based upon taxable income for the year. Taxable income differs from the results shown in the income statement as it excludes both positive and negative entries which would be taxable or deductible in other tax years and excludes components which are not taxable or deductible at any time.

Current taxes are calculated using the rates in force at the reporting date.

Cairo Communication and its subsidiaries Cairo Editore S.p.A., Cairo Pubblicità S.p.A., Diellesei S.r.l. in liquidation, Cairo Publishing S.r.l., La7 S.r.l. and Cairo Network S.r.l. (former Cairo Sport S.r.l.) participate in the national tax consolidation scheme of UT Communications S.p.A., in accordance with art. 117/129 of the Consolidated Income Tax Act.

The consolidation scheme, which regulates economic aspects pertaining to the sums deposited or received against the advantages or disadvantages arising from the national tax consolidation scheme, also allows for any increased costs or decreased benefits incurred by the companies, by participating in this procedure, to be repaid by the parent.

UT Communications S.p.A. acts as the tax parent and determines a single taxable base for the group of companies that participate in the national tax consolidation scheme, which thereby benefits from the ability of offsetting taxable profits against taxable losses in one tax return.

Each company that participates in the national tax consolidation scheme transfers its taxable profit or loss to the tax parent. For any such taxable profit reported by a subsidiary, UT Communications S.p.A. recognizes receivables equal to the IRES payable. Conversely, for any such taxable loss, reported by a subsidiary, UT Communications recognize a payable equal to IRES due on the loss that has been contractually transferred at Group level.

Deferred tax liabilities are generally recognized for all taxable temporary differences, while deferred tax assets are recognized to the extent of the probability that there will be future taxable profits which will allow for the utilization of the deductible temporary differences. Deferred taxes are calculated on the basis of the tax rates that are foreseen will be in force at the moment of realization of the asset or of the liability, based on tax legislation in force at the reporting date. Where relevant, the effects of any changes in tax rate or tax legislation are disclosed in the notes. Deferred tax assets and liabilities are shown at their net value when there is a legal right to offset current tax liabilities against tax receivable assets and when taxes relate to the same taxation authority.

Post-employment benefits

Post-employment benefit, mandatory for all Italian companies under art. 2120 of the Civil Code, are deferred remuneration and are directly related to the employee's length of service in the company, and to the employee's actual remuneration received during their period of service.

For Italian companies with at least 50 employees, post-employment benefits take the form of a defined benefit plan, solely for the amounts accrued prior to 1 January 2007 (and not yet paid at the reporting date), whereas subsequent to such date, they are recognized as a defined contribution plan. For Italian companies with less than 50 employees, post-employment benefits are considered as a defined benefit plan. All defined benefit plans are discounted. The discounting process, based on demographic and financial assumptions, is performed by independent actuaries. Following the Amendment to IAS 19 - *Employee Benefits*, the recognition of expenses related to work performed and net financial charges are recognized in the income statement, while the recognition of actuarial gains and losses arising from the re-measurement of liabilities and assets are recognized in the statement of comprehensive income.

Non-current assets

Intangible assets

Costs, including ancillary costs incurred for the acquisition of resources with no physical substance, are recognized under intangible assets when the cost is quantifiable and the asset is clearly identifiable and controlled by the Group, and where the use of the asset will generate probable future benefits to the Group. These are valued at their acquisition or production cost, including related costs – to the extent to which they are considered to have a finite life – and they are amortized to reflect their remaining useful economic lives. The amortization periods of intangible assets of various types are as follows:

Concessions, licenses, trademarks and similar rights 3 to 5 years for application software licenses

Other:

Software 3 to 5 years

Publication titles 20 years

Television rights Based on their availability period

Publication titles are amortized over a period of 20 years from the date of their acquisition based on their remaining useful lives. This amortization period is regularly reviewed to take account of the financial performance of the subsidiaries that own the title.

Registration rights (with a duration of more than 12 months) for the broadcasting of films, series, soaps, cartoons, classical concerts, short films, and the like, including ancillary charges (dubbing, editing and materials), and contributions to productions purchased under license agreements, are carried under "media rights" and amortized on an annual straight-line basis throughout the contractual term of the rights, as from the year they are available and ready for use.

If the rights have used up their airing time, regardless of the amortization already charged, the residual amount is fully expensed during in the period of the last airing.

The remaining useful life and the amortization criteria applied are reviewed on a regular basis and where change is deemed necessary, the amortization rate is restated in accordance with the "prospective" method.

Assets under development include the costs incurred for the acquisition or internal production of intangible assets, to which title has not been fully acquired or for projects to be completed. Assets under development continue to be accounted for in this item up to the time of their economic use, when they are reclassified under the relevant items of intangible assets and amortized.

Property, plant and equipment

Property, plant and equipment (PPE) are recognized when their cost can be reliably determined and when related future economic benefits can be enjoyed by the Group.

They are recognized at acquisition price or production cost, including directly associated expenses and costs, plus the share of indirect costs which can be reasonably attributed to the asset.

These assets are systematically depreciated on a straight-line basis each year at rates consistent with the remaining useful life of the asset. Depreciation rates applied are as follows

Property	3%
General equipment	20%
Motor vehicles	20%-25%
Plant and machinery	10%
Office equipment and furniture	10%-12%
Electronic equipment	20%

Land is not depreciated.

The above PPE depreciation rates are reduced by 50% during their first year of use, this percentage representing the weighted average of the entry to use of new assets, on an annual basis. Depreciation begins when the asset is ready for use.

The remaining useful life and the amortization criteria applied are reviewed on a regular basis and where change is deemed necessary, the amortization rate is restated in accordance with the “prospective” method.

The remaining useful lives of assets are reviewed annually and if incremental maintenance or other work has been carried out which changes the remaining useful life of the investment, these are adjusted accordingly.

Incremental and maintenance costs producing a significant and tangible increase in the productive capacity or security of assets, or lengthening their remaining useful life, are capitalized and recognized as an increase in the carrying amount of the asset. Ordinary maintenance costs are taken directly to profit and loss.

Leasehold improvements are recognized as PPE, on the basis of the cost incurred. The depreciation period corresponds to the lower of the remaining useful life of the asset and the term of the contract.

Impairment of assets

At least once a year, the Group reviews the recoverability of the intangible assets with an indefinite useful life, and of investments and publication titles, and whenever there are potential indicators of an impairment loss on PPE and intangible assets with a finite useful life, in order to determine whether such assets may have suffered an impairment loss. When such indicators are present, the carrying amount of the asset is reduced to reflect recoverable amount. The recoverable amount of an asset is the greater of its fair value less costs to sell, and its value in use. The fair value of a listed investment is determined according to its market price at the reporting date, in case the Stock Market price is considered to represent the effective value of the investment. In the absence of market values, estimates and valuation methods are applied based on data which is in any case evident on the market. To determine an asset's value in use, the Group calculates the present value of future estimated cash flows, inclusive of tax, by applying a pre-tax discount rate which reflects the current market valuation, including the time value of money and the specific risks inherent to the asset.

Excluding goodwill, when the impairment loss on the value of an asset no longer applies or is reduced, the carrying amount of the asset is increased up to the new estimated recoverable amount, and may not exceed the amount which would have been determined had no impairment loss been recognized.

Current assets and liabilities

Inventories

Inventories are measured at the lower of the purchase or production cost, including all directly attributable expenses, net of discounts and allowances, calculated using the weighted average cost method, and estimated realizable value. Estimated realizable value takes into account any production and direct sales costs. Inventories are adjusted for obsolete and slow moving items through a specific write-down provision.

Receivables

Trade and other current assets are recognized at their estimated realizable value.

Financial assets

They are initially recognized at fair value, which basically corresponds to consideration paid and direct expenses associated with their acquisition. Financial assets acquired and sold are recognized at their trading date, when the Group intends to acquire/sell these assets.

At the subsequent reporting dates, the financial assets that the Company has the intention and the ability to hold to maturity (held-to-maturity investments) are recognized at amortized cost, net of any impairment losses, to reflect write-downs, if any.

Investments other than those held to maturity are classified as held for trading or available for sale and are measured at the end of each reporting period at their fair value. When financial assets are held for trading, gains and losses arising from fair value changes are recognized in profit and loss. In the case of available-for-sale financial assets, gains and losses arising from fair value changes are recognized in comprehensive income. When available-for-sale financial assets are sold, redeemed or transferred, cumulative gains or losses previously recognized in comprehensive income must be reclassified from equity to profit/ (loss) for the year. This reserve is also used if alignment to fair value results in subsequent impairment of the asset until the reserve is used up. Any additional loss exceeding the reserve, should it result in an impairment loss, is taken to profit and loss.

Regarding measurement of available-for-sale assets, the directors have chosen as impairment indicators, the decline in fair value below cost of over 50%, or for a period exceeding 24 months.

Cash and cash equivalents

This item comprises cash, bank current accounts and deposits on demand, and other short-term highly liquid financial investments which are easily convertible to cash and not subject to the risk of significant value changes.

Cash and cash equivalents are recognized at their nominal amount.

Borrowings, bank loans and overdrafts

Borrowings, interest-bearing bank loans and bank overdrafts are recognized based on the amount cashed net of transaction costs, and subsequently measured at amortized cost using the current interest rate method.

Trade payables

These are recognized at their nominal amount.

Equity

Treasury shares

Treasury shares are measured at historical cost and are recognized as a reduction in equity. The result of the subsequent sale of treasury shares is recognized directly as a change in equity.

Dividends paid

Dividends payable are recognized as a change in equity in the year they are approved by the Shareholders' Meeting or by the Board of Directors in the event of an interim dividend, pursuant to art. 2433 bis of the Italian Civil Code.

Provisions for risk and charges

Provisions for risk and charges are recognized when the Group has a legal or constructive obligation resulting from a past event and for which a probability exists for the fulfillment of that obligation. The provisions reflect the best estimate of costs based on information currently available in order to fulfill the obligation at the reporting date, and are discounted when the effect is significant.

Derivative financial instruments

Hedges, recognized as "Financial assets held for trading", hedge foreign exchange risk relating to foreign currency payables (forward currency purchases coinciding with schedules of contractual payments).

Initial measurement of derivatives is made at fair value at the date of initial recognition. Fair value changes are recognized in profit or loss.

Use of estimates

The preparation of the financial statements and the notes thereto, in application of IFRS, requires that the Group carry out estimates and assumptions which affect the carrying amount of assets and liabilities and disclosure about assets and contingent liabilities at the reporting date. Estimates and assumptions used are based on experience and on other factors considered significant. Actual results could differ from these estimates. Estimates mainly relate to provisions for risks relating to receivables, obsolete inventory, publishing returns, investment measurements, amortization, depreciation, impairment of assets, taxation, provisions for risk and charges, and contingent liabilities.

Estimates and assumptions are reviewed regularly and the effects of each variation therein are recognized in the profit and loss in the period in which the estimate was revised. The effects of such revisions are reflected in the periods on which they have effect, i.e. both in the current period, and in future periods, if relevant. In this context, the persisting uncertainty factors in the short and medium economic term, which make it hard to predict a return to normal market conditions, have led to the need to make assumptions regarding future performance which are influenced by significant uncertainty, and the possibility of achieving results different from those estimated cannot be excluded for the next year, and which could therefore require adjustments to the carrying amount, even significant, although these are obviously neither currently quantifiable nor foreseeable.

The items most susceptible to these uncertainties are the allowance for impairment, inventory write-downs, non-current assets (intangible assets and investments), deferred tax assets, post-employment benefits and the provisions for risk and charges.

A summary follows of all critical measurement processes used and key assumptions made by management regarding the future in the process of applying accounting policies and that could have a significant effect on the amounts recognized in the consolidated financial statements and for which there is a risk that

significant adjustments to the carrying amount of assets and liabilities could arise in the next financial period.

Allowance for doubtful accounts

The allowance for doubtful accounts reflects management's estimate regarding the losses on the portfolio of receivables from end customers. The allowance is estimated based on the losses expected by the Group, according to past experience for similar receivables, current and past due dates, losses and receipts arising from the careful monitoring of receivable management and from projections on market and economic conditions.

The persisting uncertainty factors in the short and medium economic term, along with the resulting credit squeeze, could result in further deterioration of the financial conditions of Group debtors compared to deterioration already considered in the quantification of the recognized allowance for impairment.

Deferred tax assets

Deferred tax assets are recognized to the extent to which it is considered probable that future taxable income will be generated to allow the utilization of deductible temporary differences. The realizable value of deferred tax assets is periodically reviewed according to the future taxable income foreseen in the Group's most recent plans.

Recoverable amount of non-current assets (including goodwill)

Non-current assets include property, plant and equipment, intangible assets (including goodwill), investments and other financial assets. Management periodically reviews the carrying amount of the non-current assets held and used, and those of assets held for sale, as and when circumstances require such revision. This is performed by the comparison of the carrying amount of the asset and the greater of the fair value, less costs to sell, and value in use. Fair value is determined according to market prices. In the absence of market value, estimates and valuation models are used based on data available on the market. Value in use is determined based on the estimate of expected cash flows from the use or sale of the asset and is discounted using appropriate discount rates. When the carrying amount of a non-current asset has suffered an impairment loss, the Group recognizes an impairment loss equal to the positive difference between the greater of carrying amount of the asset and its recoverable amount from its use or sale, as determined according to the Group's most recent plans.

For the preparation of the consolidated financial statements at 31 December 2014, and in particular in the performance of impairment tests on intangible assets and property, plant and equipment, the different segments of the Group have taken into account the expected 2015 performance, whose assumptions and results are in line with the information disclosed in the section on "*significant events after the reporting period and business outlook*" in the Directors' Report. In addition, for the subsequent years of the plan,

necessary adjustments have been cautiously made to take account of the deep market changes resulting from the current economic and financial crisis. No significant impairment was required based on such figures in the plan.

Provisions for risks and charges

The provisions for risk and charges relating to contingent liabilities of a legal or fiscal nature are made on the basis of estimates made by the Directors, on the basis of valuations made by the Company's legal and fiscal advisors on the probable charge that can be reasonably expected to fulfill the obligation.

Risk management

The main fiscal, legal and financial risks to which the Cairo Communication Group is exposed, as well as the policies put in place by Management for their management, are explained in Note 35 and Note 37. Reference is made to the Directors' Report for operational and business risks.

Accounting standards, amendments and interpretations applied from 1^o January 2014

The following accounting standards, amendments and interpretations, revised also following IASB's yearly improvement process, were applied for the first time starting from 1 January 2014:

- **IFRS 10 – Consolidated Financial Statements** - The standard, issued by the IASB in May 2011, supersedes SIC 12 - *Consolidation: special purpose entities (vehicles)* and parts of IAS 27 – *Consolidated and separate financial statement*, renamed *Separate financial statements*. It sets out the accounting requirements of equity investments in the separate financial statements. IFRS 10 introduces a new control model that is applied to all entities, including vehicles, based on the power exercised by the Group over these entities, exposure or rights to variable returns from its involvement with these entities, and the ability to use its power to influence these variable returns. The IASB requires retrospective application of the standard from 1 January 2013. The competent EU bodies have completed the approval process of the standard, deferring the date of application to 1 January 2014, allowing however early adoption beginning from 1 January 2013.

The adoption of the new standard did not require the redefinition of the scope of consolidation.

- **IFRS 11 – Joint arrangements** – The standard, issued by the IASB in May 2011, supersedes IAS 31 – *Interests in Joint Ventures* and SIC 13 – *Jointly controlled entities - Nonmonetary contributions by venturers*. IFRS 11 provides criteria to identify joint arrangements based on the rights and obligations arising from the agreements, rather than on their legal form. It uses only the equity method to account for interests in joint ventures in the consolidated financial statements. Following issue of this standard, IAS 28 – *Investments in associates* was amended to include within its framework, from the effective date of the standard, interests in joint ventures. The IASB requires retrospective application

of the standard from 1 January 2013. The competent EU bodies have completed the approval process of the standard, deferring the date of application to 1 January 2014, allowing however early adoption beginning from 1 January 2013. The adoption by the Cairo Communication Group of this standard had no impact on the data in the Annual Financial Report.

- **IFRS 12 – Disclosure of interests in other entities** – The standard, issued by the IASB in May 2011, establishes the disclosure of additional information to provide on all types of interests, including those in subsidiaries, joint arrangements, associates, special purpose entities and other unconsolidated structured entities. The IASB requires retrospective application of the standard from 1 January 2013. The competent EU bodies have completed the approval process of the standard, deferring the date of application to 1 January 2014, allowing however early adoption beginning from 1 January 2013. The effects of the adoption of the new standard are limited to disclosure relating to interests in other entities, to provide in the notes to the annual consolidated financial statements.
- **IAS 27 (2011) - Separate financial statements** – Following issue of IFRS 10 in May 2011, the IASB narrowed the scope of application of IAS 27 only to the separate financial statements. The standard specifically governs the accounting treatment of investments in the separate financial statements and is applicable from 1 January 2014. The adoption by the Cairo Communication Group of this standard had no impact on the data in the Parent’s Financial Statements.
- **IAS 28 (2011) - Investments in associates and joint ventures** - Following issue of IFRS 11 in May 2011, the IASB amended the existing standard to include in its framework investments in joint ventures, and to govern the reduction of the interest which does not result in ceasing to apply the equity method. The standard is applicable from 1 January 2014. The adoption by the Cairo Communication Group of this standard had no impact on the data in the Annual Financial Report.
- **Amendments to IAS 32 – Financial Instruments: Presentation** – The amendments issued by the IASB in December 2011 clarify the application of criteria for the offsetting of financial assets and liabilities appearing in IAS 32. The amendments must be applied retrospectively from 1 January 2014. The adoption by the Cairo Communication Group of this standard had no impact on the data in the Annual Financial Report.
- **Amendments to IFRS 10, IFRS 11 and IFRS 12 – Transition guidance amendments** – On 28 June 2012, the IASB published the amendments to IFRS applicable, together with the relevant standards, from financial periods beginning on or after 1 January 2013, unless applied earlier. The document introduces amendments to IFRS 10, 11 and 12 to clarify how an investor should adjust only the previous comparative period retrospectively and provide the information under IAS 8, paragraph 8, letter f, exempting from the provisions of the other letters of the same paragraph. IFRS 12 was further amended, in derogation of the request of adjusted comparative information, by limiting the

request of presenting comparative information for disclosures regarding unconsolidated "structured entities" in periods prior to the date of application of IFRS 12.

- ***Amendments to IFRS 10, IFRS 12 and IAS 27 – Investment entities*** – The amendment, issued by the IASB in October 2012, integrates IFRS 10 by clarifying the definition of investment entities and clarifies its consolidation methods. The amendment to IFRS 12 integrates the standard by clarifying the disclosures to provide and the assessments on how to determine investment entities. The amendment to IAS 27 integrates the standard by establishing the disclosures that the investment entity is required to provide if it is also a controlling entity. The adoption by the Cairo Communication Group of this standard had no impact on the data in the Annual Financial Report.
- ***Amendments to IAS 36 – Recoverable amount disclosures on non-financial assets*** – The standard, issued by the IASB in May 2013, governs the disclosures to provide on the recoverable amount of impaired assets, if the amount is based on the fair value less costs of disposal. The amendments must be applied retrospectively to financial periods beginning on or after 1 January 2014. Early application is allowed for periods in which the entity has already applied IFRS 13.
- ***Amendments to IAS 39 – Novation of derivatives and continuation of hedge accounting*** – The standard, issued by the IASB in June 2013, clarifies that the amendments allow continuation of hedge accounting in the circumstance in which the derivative, which has been designated as an hedging instrument, is novated as a consequence of laws or regulations in order to replace the original counterparty to ensure performance of the obligation if certain conditions are met. The same amendment will also be included in IFRS 9 *Financial instruments*. These amendments must be applied retrospectively to financial periods beginning on or after 1^o January 2014. The adoption by the Cairo Communication Group of this standard had no impact on the data in the Annual Financial Report.
- ***IFRIC 21 – Levies*** - The interpretation, issued by the IASB in May 2013, provides guidance on when to recognize liabilities for a levy imposed by a government, with the exception of those governed by other standards (i.e. IAS 12 – *Income tax*). IAS 37 establishes the recognition criteria of liabilities, one of which is the existence of a present obligation on an entity resulting from past events (obligating event). The interpretation clarifies that the obligating event that gives rise to liability for payment of a levy is explained by the relevant legislation that gives rise to its payment. IFRIC 21 is applicable according to the IASB for financial years beginning on or after 1 January 2014, while, according to the EU Regulation, from 17 June 2014. The adoption by the Cairo Communication Group of this standard had no impact on the data in the Annual Financial Report.

Accounting standards, amendments and interpretations approved by the European Union, yet to be enforced, and not adopted in advance by the Group

- ***Amendments to IAS 19 - Employee contributions to defined-benefit plans*** - The amendment, issued by the IASB in November 2013, applies to employee contributions or to defined benefit plans. The purpose of the amendments is to simplify the accounting of contributions that are independent of the number of years of service. The amendments are effective for financial periods beginning on or after 1 July 2014; early application is allowed.
- ***Improvements to IFRS: 2010-2012 Cycle*** - On 12 December 2013, the IASB published “*Annual Improvements to IFRSs: 2010-2012 Cycle*”, which acknowledges the amendments to the standards as part of their annual improvement process. The amendments are applied to financial periods beginning on or after 1 July 2014. Early application is allowed. The main amendments regard:
 - IFRS 2 Share-based payments*** – Amendments have been made to the definitions of "vesting condition" and "market condition", while further definitions have been added of "performance condition" and "service condition" (previously included in the definition of "vesting condition").
 - IFRS 3 Business combinations***- The amendments clarify that a contingent consideration classified as an asset or liability should be measured at fair value at each balance sheet date, regardless of whether the contingent consideration is a financial instrument to which IFRS 9 or IAS 39 applies or a non-financial asset or liability. Changes in fair value (other than period measurement adjustments) are presented in profit and loss.
 - IFRS 8 Operating segments*** - The amendments require an entity to disclose those factors used by management to identify the entity's reportable segments when operating segments have been aggregated, including a description of the aggregated operating segments and economic indicators considered in determining whether these operating segments have "similar economic characteristics". The amendments also clarify that the reconciliation between total assets of the operating segments and the total assets of the entity is provided only if the total assets of the operating segments are regularly provided to the chief operating decision-maker.
 - IFRS 13 Fair Value Measurement*** – Amendments have been made to the *Basis for Conclusions* in order to clarify that short-term receivables and payables are still able to be measured on an undiscounted basis where the effect of discounting is immaterial.
 - IAS 16 Property, plant and equipment and IAS 38 Intangible assets*** – The amendments have eliminated inconsistency in the measurement of accumulated depreciation when a tangible or intangible asset is being revalued. The new requirements clarify that the gross carrying amount is adjusted in a manner consistent with the revaluation of the carrying amount of the asset, and that accumulated depreciation is equal to the difference between gross carrying amount and carrying amount, less subsequent depreciation.

IAS 24 Related party disclosures - It clarifies the provisions that apply in the identification of related party transactions and disclosure to provide when the activities of key management personnel are provided by a management entity (not by natural persons). In this case, the management entity is considered a related party and separate disclosure should be given on the provision of services of the management entity; as part of the disclosure on compensation to key management personnel, the components of compensation paid to the management entity need not be disclosed.

- **Improvements to IFRS: 2011-2013 Cycle** - On 12 December 2013, the IASB published “*Annual Improvements to IFRSs: 2011-2013 Cycle*”, which acknowledges the amendments to the standards as part of their annual improvement process. The amendments are applied to financial periods beginning on or after 1 July 2014. Early application is allowed. The main amendments regard:

IFRS 1 First-time Adoption of International Financial Reporting Standards – It clarifies that a first-time adopter, as an alternative to the application of a principle currently in force on the date of the first IAS/ IFRS financial statements, may opt for early application of a new standard intended to replace the principle in force. The option is admitted when the new standard allows early application. The entity is required to apply the same version of the standard in all periods presented in the first IAS/IFRS financial statements.

IFRS 3 Business combinations – The amendments aim to clarify the exclusion from the application scope of IFRS 3 of all types of joint arrangement.

IFRS 13 Fair Value Measurement – IFRS 13, paragraph 52 (*portfolio exception*), in its current version, restricts to financial assets and liabilities included in the application scope of IAS 39 the possibility of fair value measurement on a net basis. The amendment clarifies that the possibility of fair value measurement on a net basis also applies to contracts within the application scope of IAS 39 (or IFRS 9), but that do not meet the definition of financial assets and liabilities in IAS 32, such as contracts to buy and sell non-financial items that can be settled net in cash.

IAS 40 – Investment Property - The amendment clarifies that IFRS 3 and IAS 40 are not mutually exclusive and that, in order to determine whether the purchase of a property falls within the scope of IFRS 3, it is necessary to refer to the specific indications in IFRS 3; instead, to determine whether the purchase of such property falls within the scope of IAS 40, it is necessary to refer to the specific indications in IAS 40.

Accounting standards, amendments and interpretations not approved by the European Union, yet to be enforced, and not adopted in advance by the Group

- **IFRS 14 Regulatory Deferral Accounts** – IFRS 14, published by the IASB in January 2014, allows only first-time adopters of IFRSs to continue to recognize the amounts relating to rate regulation according to previously adopted accounting standards. In order to improve comparability with the entities that already apply the IFRSs and do not recognize these amounts, the standard requires that

the effect of rate regulation should be presented separately from the other items. The principle applies from 1 January 2016; early application is allowed.

- ***Amendments to IFRS 11 Joint arrangements*** - The amendments, issued by the IASB in May 2014, provide clarification on the accounting of purchases of interests in a joint operation whose activity constitutes a business. The amendments are effective retrospectively for annual periods beginning on or after 1 January 2016; early application is allowed.
- ***Amendments to IAS 16 Property, plant and equipment and IAS 38 Intangible assets*** - The amendments, issued by the IASB in May 2014, aim to clarify that depreciation criteria determined in accordance with revenue are not appropriate, as the revenue generated by an activity that includes the use of an asset generally reflect factors other than the consumption of economic benefits of the asset. The IASB also clarified the presumption that revenue is not appropriate to measure the consumption of the economic benefits generated by an intangible asset. This presumption may, however, be overcome in limited circumstances. These amendments are effective for annual periods beginning on or after 1 January 2016; early application is allowed.
- ***IFRS 15 - Revenue from contracts with customers*** - The standard, published by the IASB in May 2014, introduces a general model to determine whether, when and to what extent will revenue be recognized. The standard replaces the recognition criteria set out in IAS 18 - *Revenue*, IAS 11 - *Work in progress* and IFRIC 13 - *Customer Loyalty Programmes*. IFRS 15 applies to financial periods beginning on or after 1 January 2017; early application is allowed.
- ***IFRS 9 – Financial instruments***. The standard, published by the IASB in July 2014, supersedes IAS 39 - *Financial Instruments: Recognition and Measurement*. IFRS 9 introduces new provisions for the classification and measurement of financial instruments, including a new model for expected losses in the calculation of impairment losses on financial assets, and new general provisions for hedge accounting. It also includes provisions for the recognition and derecognition of financial instruments in accordance with the current IAS 39. The new standard will be applicable retrospectively from 1 January 2018; early application is allowed.
- ***Amendment to IAS 27 Separate financial statements***. In August 2014, the IASB published Equity Method in Separate Financial Statements; the amendments to IAS 27 will allow entities to use the equity method to account for investments in subsidiaries, joint ventures and associates in the separate financial statements. The amendments are effective for financial periods beginning on or after 1 January 2016; early application is allowed.
- ***Amendment to IFRS 10 Consolidated financial statements and IAS 28 Investments in associates and joint ventures***. The amendment issued by the IASB in September 2014 highlights the changes to address an inconsistency in dealing with the sale or contribution of assets between an investor and its associate or joint venture. The main consequence of the changes is that a full gain or loss is

recognized when a transaction involves a business. The amendments are applied to financial periods beginning on or after 1 January 2016.

- **Improvements to IFRS: 2012-2014 Cycle.** In September 2014, the IASB published “Annual Improvements to IFRSs: 2012-2014 Cycle”, which acknowledges the amendments to the standards as part of their annual improvement process. The amendments are applied to financial periods beginning on or after 1 January 2016. Early application is allowed. The main amendments regard:

IFRS 5 Non-current assets held for sale and discontinued operations – The amendment introduces specific guidance to IFRS 5 in case an entity reclassifies an asset (or disposal group) from held for sale to held-for-distribution (or vice versa), or when recognition of an asset held-for-distribution ceases.

IAS 19 Employee benefits - The amendment to IAS 19 clarifies that high quality corporate bonds used to determine the discount rate of post-employment benefits must be issued in the same currency used in the payment of the benefits.

IAS 34 Interim financial reporting - The document clarifies the requirements in the event that the disclosures required are presented in the interim financial report but not in the interim financial statements. The amendment requires that the disclosures be incorporated by cross-reference between the interim financial statements and wherever they are included within the interim financial report and that the document be available to users of the financial statements on the same terms as the interim financial statements and at the same time.

IFRS 7 Financial instruments: disclosures- The document introduces additional guidance to clarify whether a servicing contract constitutes a continuing involvement in a transferred asset for the purposes of applying these disclosure requirements to the transferred assets.

- **Amendment to IAS 1.** In December 2014, the IASB published “Disclosure Initiative” The main amendments regard: Materiality and aggregation: An entity must not reduce the understandability of its financial statements by obscuring useful information with irrelevant information or by aggregating relevant information that has different characteristics or functions. Additional subtotals must be reconciled to the subtotal and totals required.

Information to be presented in the statement of financial position and of comprehensive income: specific items of profit or loss, other comprehensive income and the statement of financial position can be disaggregated. Subtotals must: be made up of items recognized and measured in accordance with IFRS, be presented and labeled in order to make the components of the subtotal clear and understandable; be consistent from period to period. Statement of other comprehensive income for the year: the share of other comprehensive income of associates and joint ventures accounted for using the equity method must be presented in aggregate form but separately from other comprehensive income, as a single item, based on whether the items will or will not subsequently

be reclassified to profit or loss. Notes – Structure: the entity is free to decide the order of presentation in the financial statements, but must consider the effect on the understandability and comparability of its financial statements, emphasizing the most relevant operating segments for the understanding of its financial performance and financial position.

The amendments are applied to financial periods beginning on or after 1 January 2016. Early application is allowed.

- ***Amendment to IFRS 10, IFRS 12 and IAS 28 - Investment entities: consolidation exceptions*** - In December 2014, the IASB published "Investment Entities: Applying the Consolidation Exception". The main amendments regard:

IFRS 10 Consolidated financial statements – The amendments to the IFRS clarify that the exemption from presenting consolidated financial statements applies to a parent entity that is a subsidiary of an investment entity, when the investment entity measures all of its subsidiaries at fair value.

IAS 28 Investments in Associates - The amendment to IAS 28 allows a non-investment entity, when applying the equity method of accounting for its investment in an associate or a joint venture that is an investment entity, to retain the fair value measurement that is applied by that associate or joint venture to its subsidiaries.

IAS 12 Disclosure of interests in other entities - the amendment clarifies that this principle does not apply to an investment entity that prepares the financial statements in which all of its associates are measured at fair value through profit and loss.

The amendments are applied retrospectively to financial periods beginning on or after 1 January 2016. Early application is allowed.

NOTES TO THE CONSOLIDATED INCOME STATEMENT

Regarding the items of the consolidated income statement, following is the analysis of the main items of cost and revenue for the year ended 31 December 2014.

Comparative figures refer to the annual financial report at 31 December 2013. To provide a better understanding of the figures, it should be noted that the 2013 income statement included the costs and revenue of La7 S.r.l., which was consolidated on 1 May 2013, with regard only to the May-December eight-month period.

1. Revenue

The following table shows gross operating revenue, agency discounts and net operating revenue:

(€ thousands)	31/12/2014	31/12/2013
Gross operating revenue	266,014	276,704
Advertising agency discounts	(25,748)	(27,190)
Net operating revenue	240,266	249,514

Revenue is generated exclusively in Italy and an analysis by geographical area is pointless. An analysis of revenue by business segment is provided in [Note 15](#).

Gross revenue can be analyzed as follows:

Description	31/12/2014	31/12/2013
TV advertising	155,215	163,213
Print media advertising	27,977	29,229
Stadium signage	2,537	2,536
Internet advertising	1,244	966
Revenue from concession of programming schedule spaces	982	1,295
Other TV revenue	2,180	2,070
Magazine over-the-counter sales	73,400	74,791
Subscriptions	2,883	2,992
Books and catalogues	981	910
VAT relating to publications	(1,486)	(1,398)
Other	100	100
Total gross operating revenue	266,014	276,704

The consolidation of La7 S.r.l. for the entire twelve months (as compared to the May-December eight-month period of 2013 included in the same period last year) brought no significant change to revenue, since over 90% of La7 S.r.l. revenue comes from advertising sales generated by Cairo Communication under the advertising concession contract in effect before the acquisition.

As explained more in detail in the Directors' Report, in 2014:

- it confirmed the excellent circulation results, with revenue at Euro 73.4 million versus Euro 74.8 million in 2013,
- Group gross print advertising revenue, which reached Euro 27.2 million, dropped by 3.9% versus 2013 (*ACNielsen*, -6.5% the magazine advertising market in 2014),
- gross advertising sales on La7 and La7d channels amounted to Euro 152.9 million (Euro 157.5 million in 2013).

2. Other revenue and income

“Other revenue and income”, amounting to Euro 11,927 thousand (Euro 7,985 thousand in 2013), consist of revenue from pulp and paper sales, prior-year income and release of risk provisions also as a result of settlement agreements defined during the year, charging of technical advertising costs and other items of revenue other than operating revenue. The increase versus 2013 is due mainly to the consolidation of La7 for the entire twelve months (versus the May-December eight-month period included in 2013).

3. Changes in finished goods

The item amounts to a negative Euro 28 thousand (a negative Euro 61 thousand in 2013), arising from the use of the magazine sales during the ordinary course of business relating to Cairo Editore S.p.A. and Cairo Publishing S.r.l.

4. Raw materials, consumables and supplies

Raw materials mainly relate to the activities of Cairo Editore, Cairo Publishing and La7 and include the main items:

Description	31/12/2014	31/12/2013
Paper	21,973	25,528
Set design materials	160	299
Equipment and sundry materials	1,678	1,211
Change in inventories of paper, equipment and sundry materials, TV programmes and the like	778	1,249
Total raw materials, consumables and supplies	24,589	28,287

The change in inventories, amounting to Euro 778 thousand, refers to:

- Euro 88 thousand for the change in inventories of in-house TV programmes of La7 S.r.l. or programmes purchased externally and yet to be aired, rights on films, soaps and the like and related ancillary costs within one year and yet to be aired;
- Euro 690 thousand for the change in inventories of paper and other consumables of Cairo Editore S.p.A.

5. Services

As shown in the following chart, this item mainly comprises publishers' fees, agents' commissions, external processing, consultancies and collaborations, general and administrative costs, and can be analyzed as follows:

Description	31/12/2014	31/12/2013
Direct brokerage costs	13,874	51,824
Technical costs	857	410
Administrative costs	4,706	4,806
Consultancies and collaborations	14,309	18,370
External processing	17,098	17,618
Sub-contracted TV programmes	17,794	8,460
Professional and artistic services and other TV consulting	10,510	5,023
Shooting, crew, editing, and outdoor TV activities	1,904	2,027
News and sport information services and TV news agency	1,994	1,561
TV broadcasting services	11,806	6,475
TV artwork	523	451
Outdoor TV links	612	697
Advertising and launch promotion costs	-	965
Advertising and promotion	6,655	6,581
Organizational costs and overheads	11,185	8,853
Total services	113,827	134,121

The drop in costs for services was mainly due to the decrease versus 2013 in "direct brokerage costs", which includes publishers' fees and agents' commissions. This decrease is related to the consolidation of La7 S.r.l. for the entire twelve months (versus the May-December eight-month period included in 2013), and the resulting reversal of intercompany publishers' fees, replaced by the direct costs incurred by La7. The consolidation produced the concurrent increase in costs for services related to TV activities, in costs for leased assets and in personnel expense, as explained below.

The increases versus 2013 in "sub-contracted TV programmes", "professional and artistic services and other TV consulting", "costs for shooting, crew, editing, and outdoor TV activities", "news and sport information services and TV news agency", "TV broadcasting services", "TV artwork", and "outdoor TV links", are explained by the fact that the 2013 income statement included La7 S.r.l. costs for only the May-December eight-month period.

In 2013, "advertising and launch costs" referred to the advertising and promotional costs incurred for the new magazine "Settimanale Giallo".

"Publishers' fees" also include Euro 2,002 thousand of Torino Football Club S.p.A., a subsidiary of U.T. Communications S.p.A., under the advertising concession agreement with Cairo Pubblicità S.p.A. as explained in [Note 36](#) to related-party transactions.

6. Use of third-party assets

The item amounts to Euro 22,811 thousand (Euro 17,828 thousand at 31 December 2013) and mainly includes costs for journalistic, sport and TV programme rights, lease payments for property, office equipment and royalties for copyrights.

Description	31/12/2014	31/12/2013
Lease payments for property	3,660	3,291
Rental of TV studios	660	607
Rental fees for TV studio equipment	1,454	1,129
TV programme rights	8,464	7,293
Sport rights	209	340
Journalistic rights	2,553	1,529
Copyrights (SIAE, IMAIE, SCF, AFI)	3,933	2,390
Royalty expense and sundry rights	851	448
Other costs for use of third-party assets	1,027	801
Total costs for use of third-party assets	22,811	17,828

Increases versus 2013 in “rental of TV studios”, “rental fees for TV studio equipment”, “TV programme rights”, “journalistic rights”, “other copyrights” (SIAE, IMAIE, SCF, AFI) and “royalty expense and sundry rights”, are attributable to the fact that the 2014 income statement included La7 S.r.l. costs for the entire 12 months (versus the May-December eight-month period included in 2013)

7. Personnel expense

The item can be analyzed as follows:

Description	31/12/2014	31/12/2013
Wages and salaries	43,613	35,534
Social security charges	15,068	11,086
Post-employment benefits	1,087	1,102
Other expense	866	1,067
Total	60,634	48,789

The increase in “personnel expense” is also mainly attributable to the consolidation of La7 S.r.l. for the entire year (versus the May-December eight-month period included in 2013). In 2014, total “personnel

expense” of La7 S.r.l. amounted to Euro 34,221 thousand (Euro 23,107 thousand in the May-December eight-month period of 2013).

8. Amortization, depreciation, provisions and impairment losses

This item can be analyzed as follows:

Description	31/12/2014	31/12/2013
Amortization of intangible assets	3,155	1,065
Depreciation of property, plant and equipment	452	563
Allowance for impairment	1,344	2,857
Provisions for risk and charges	270	1,121
Total amortization, depreciation, provisions and impairment losses	5,221	5,606

The increase in “amortization of intangible assets” is mainly due to the consolidation of La7 S.r.l. for the entire year (versus the May-December eight-month period included in 2013).

It should be noted that, as a result of impairments made in the allocation of the purchase price of the investment in La7 S.r.l., explained in Note 10, lower levels of depreciation of "property, plant and equipment" - Euro 2,794 thousand - and amortization of intangible assets - Euro 15,442 thousand - were recognized in 2014.

9. Other operating costs

The item can be analyzed as follows:

Description	31/12/2014	31/12/2013
Deductible and non-deductible taxes during the year	219	255
Prior-year expenses	1,053	699
Other	849	774
Total other operating costs	2,121	1,728

10. Non-recurring income from the acquisition of La7 S.r.l.

At 31 December 2013, the item amounted to Euro 57,066 thousand and referred to the excess of the "fair value" of assets acquired and liabilities assumed of La7 S.r.l. at acquisition date (30 April 2013) over the price paid. The acquisition of La7 S.r.l. was accounted for under IFRS 3, applying the so-called "acquisition method", taking into account the future income capacity of La7 S.r.l. at the acquisition date. This approach determined:

-
- the full write-down of non-current assets at the date of acquisition of La7, consisting primarily of TV broadcasting rights, and specific technical equipment, whose value was deemed unrecoverable in view of the income prospects of La7 S.r.l. at the acquisition date. This resulted in the full write-down of these assets of Euro 53,124 thousand;
 - the recognition of “provisions for future risks and charges” of Euro 21,389 thousand, regarding certain contracts whose non-discretionary costs to fulfill obligations exceeded the assumed economic benefits, and specific risk situations related to existing and/or performed contracts and pending litigation,

Owing to the income prospects of the subsidiary La7 S.r.l. at the acquisition date, and the related uncertainties, no tax effect was considered in the purchase price allocation.

As shown in the cash flow statement, in 2013 the acquisition of La7 S.r.l. had generated an increase in consolidated cash of Euro 109.2 million, the difference between net cash acquired (Euro 115 million) and the purchase price paid, which includes the price adjustment of Euro 4.8 million agreed between Cairo Communication and Telecom Italia Media (Euro 5.8 million). As explained further in Note 35, under the contract to acquire the entire share capital of La7, for a period of 24 months following acquisition, Cairo Communication undertakes to use the financial resources resulting from the contribution received from Telecom Italia Media in the exclusive interest of La7 and to restructure the company, and to not distribute dividends or reserves of La7.

In 2013, the acquisition-related charges for the subsidiary La7 S.r.l., amounting to Euro 1,917 thousand, were recognized under "non-recurring costs for services" and were attributable to fees paid during the year to advisors and to legal and financial consultants in the due diligence, negotiation and dealing stages.

11. Profit/ (loss) on investments

At 31 December 2013, this item, amounting to Euro 699 thousand, referred to the gains from the sale of n. 153,000 shares held in Dmail Group.

12. Net financial income

This item refers to financial income totaling Euro 2,468 thousand (Euro 3,391 thousand at 31 December 2013), net of financial expense of Euro 639 thousand (Euro 490 thousand at 31 December 2013), analyzed as follows:

Description	31/12/2014	31/12/2013
Interest income on bank and postal accounts	2,452	3,344
Other	16	47
Total financial income	2,468	3,391
Bank interest expense	(113)	(2)
Other financial expense	(526)	(488)
Total financial expense	(639)	(490)
Net financial income	1,829	2,901

Financial income includes interest on fixed-term deposits in current accounts and on treasury bank accounts used to employ liquidity.

13. Income tax

This item can be analyzed as follows:

Description	31/12/2014	31/12/2013
IRES for the year	(2,010)	3,946
IRAP for the year	2,013	1,790
Deferred tax income and expenses	970	(116)
Total current and deferred income tax	973	5,620

In accordance with relevant IFRS, the deferred tax income of a number of Cairo Communication Group companies relates mainly to the accrual of provision pertaining to the year, but having deferred tax deductibility (allowance for impairment and provisions for risks and charges).

The tax charge for the period considers the benefit arising from the tax loss of La7 S.r.l.

The reconciliation of the effective and theoretical tax charge can be analyzed as follows:

	31/12/2014	31/12/2013
Pre-tax profit	24,789	79,828
Theoretical income tax charge (27.5%)	6,817	21,952
Tax effect of non-recurring income in the consolidated financial statements for the acquisition of La7	-	(15,693)
Other tax effects from the consolidation and the purchase price allocation of La7	(6,169)	(2,356)
Tax effects of other permanent differences	(1,688)	(72)
Irap	2,013	1,790
Current and deferred income tax for the year	973	5,620

For a clearer understanding of the reconciliation of the effective and theoretical tax charge, IRAP has not been taken into account as this is not based on pre-tax profit, and this would generate a distorting effect between one year and the other. However, the theoretical tax charge has been calculated using the current IRES tax rate of 27.5%.

14. Loss from discontinued operations

This includes the results of Diellesei S.p.A. in liquidation, which can be analyzed as follows:

Description	31/12/2014	31/12/2013
Other revenue and income	-	-
Cost of services	(1)	(1)
Amortization, depreciation, provisions and impairment losses	-	-
EBIT	(1)	(1)
Net financial income / (expense)	-	-
Pre-tax profit	(1)	(1)
Income tax	-	(5)
Loss from discontinued operations	(1)	(6)

With regard to the financial situation, cash absorbed by the liquidation proceedings of Diellesei in 2014 amounted to Euro 2 thousand (Euro 54 thousand in 2013).

15. Segment reporting

For a clearer understanding of the Group's economic performance, the analysis is focused on the results achieved during the year by each business segment, which has been identified, in compliance with IFRS 8 – *Operating segments*, based on internal reporting which is regularly examined by the directors.

The Group is organized in business units, each in turn structured around specific products and services, and has five reportable business segments:

- **magazine publishing**, the Group operates as a publisher of magazines and books through its subsidiaries Cairo Editore - which incorporated Editoriale Giorgio Mondadori in 2009 and publishes weeklies “Settimanale DIPIU”, “DIPIU’ TV”, “Diva e Donna”, “TV Mia” and supplements “Settimanale DIPIU’ e DIPIU’TV Cucina e Stellare”, “Settimanale Nuovo”, “F” “Settimanale Giallo” and monthlies “For Men Magazine”, “Natural Style”, “Bell’Italia”, “Bell’Europa”, “In Viaggio”, “Airone”, “Gardenia”, “Arte” and “Antiquariato” - and Cairo Publishing, publisher of books;
- **advertising**, the segment managed by Cairo Communication and Cairo Pubblicità, which work together in advertising sales in print media for Cairo Editore and Editoriale Genesis (“Prima Comunicazione”), on TV for La7 and La7d, and Turner Broadcasting (Cartoon Network,

- Boomerang, CNN), on the Internet and for the sale of stadium advertising spaces at the “Olimpico” football pitch in Turin for Torino FC;
- **TV publishing (La7)**, as mentioned earlier, since 1 May 2013 following the acquisition of La7 S.r.l., the Group has operated as a TV publisher of La7 and La7d broadcasters respectively on channel 7 and channel 29 on the digital terrestrial platform;
 - **network operator (Cairo Network)**, as previously explained, in 2014 the subsidiary Cairo Network S.r.l. (former Cairo Sport S.r.l.) took part in the tender procedure opened by the Ministry of Economic Development for the assignment of rights to use TV frequencies for digital terrestrial broadcasting systems, submitting its binding bid and winning the rights to use a lot of frequencies ("Mux") for a period of 20 years. With the acquisition and realization of the Mux, the Cairo Communication Group started operations as a network operator.
 - **Il Trovatore**, which manages its own search engine and provides technological services mainly within the Group.

No combinations were made for the definition of reportable business segments

2014 (€ thousands)	Magazine Publishing	Advertising	TV publishing La7 Current operations	Non- recurring items	Trovato- re	Network operator Cairo Network	Intra- group and unallocated	Total
Gross operating revenue	96,708	181,332	110,913	-	834	-	(123,773)	266,014
Advertising agency discounts	-	(25,748)	-	-	-	-	-	(25,748)
Net operating revenue	96,708	155,584	110,913	-	834	-	(123,773)	240,266
Change in inventories	(28)	-	-	-	-	-	-	(28)
Other income	1,321	919	9,323	-	62	2	-	11,627
Total revenue	98,001	156,503	120,236	-	896	2	(123,773)	251,865
Production cost	(65,098)	(144,026)	(77,016)	-	(673)	(8)	123,773	(163,048)
Personnel expense	(19,120)	(7,251)	(34,221)	-	(42)	-	-	(60,634)
Gross operating profit (EBITDA)	13,783	5,226	8,999	-	181	(6)	-	28,183
Amortization, depreciation, provisions and impairment losses	(1,261)	(1,181)	(2,778)	-	-	(1)	-	(5,221)
Operating profit (EBIT)	12,522	4,045	6,221	-	181	(7)	-	22,962
Income / (loss) on investments	-	(2)	-	-	-	-	-	(2)
Net financial income	17	390	1,423	-	(1)	-	-	1,829
Non-recurring income from acquisition of La7 S.r.l.	-	-	-	-	-	-	-	-
Pre-tax profit	12,539	4,433	7,644	-	180	(7)	-	24,789
Income tax	(4,502)	(1,795)	5,385	-	(61)	-	-	(973)
Profit from continuing operations attributable to the owners of the parent	8,037	2,638	13,029	-	119	(7)	-	23,816
Profit / (loss) from discontinued operations	-	-	-	-	-	-	(1)	(1)
Profit	8,037	2,638	13,029	-	119	(7)	(1)	23,815
Non-controlling interests	-	-	-	-	24	-	-	24

2013	Magazine Publishing	Advertising	TV publishing La7 (*)		Trovatore	Network operator	Intra-group	Total
(€ thousands)			Current operations	Non-recurring items		Cairo Network	and unallocated	
Gross operating revenue	99,063	191,681	77,019	-	485	-	(91,544)	276,704
Advertising agency discounts	-	(27,190)	-	-	-	-	-	(27,190)
Net operating revenue	99,063	164,491	77,019	-	485	-	(91,544)	249,514
Change in inventories	(61)	-	-	-	-	-	-	(61)
Other income	2,381	5,539	2,391	-	1	-	(2,327)	7,985
Total revenue	101,383	170,030	79,410	-	486	-	(93,871)	257,438
Production cost	(69,867)	(152,936)	(52,644)	(1,917)	(387)	-	93,871	(183,880)
Personnel expense	(19,117)	(6,531)	(23,107)	-	(34)	-	-	(48,789)
Gross operating profit (EBITDA)	12,399	10,563	3,659	(1,917)	65	-	-	24,768
Amortization, depreciation, provisions and impairment losses	(1,323)	(2,585)	(1,698)	-	-	-	-	(5,606)
Operating profit (EBIT)	11,076	7,978	1,961	(1,917)	65	-	-	19,162
Income / (loss) on investments	-	699	-	-	-	-	-	699
Net financial income	40	1,165	1,697	-	(1)	-	-	2,901
Non-recurring income from acquisition of La7 S.r.l.	-	-	-	57,066	-	-	-	57,066
Pre-tax profit	11,116	9,842	3,658	55,149	64	-	-	79,828
Income tax	(4,118)	(3,610)	2,131	-	(23)	-	-	(5,620)
Non-controlling interests	-	-	-	-	(8)	-	-	(8)
Profit from continuing operations attributable to the owners of the parent	6,998	6,232	5,789	55,149	41	-	-	74,208
Profit / (loss) from discontinued operations	-	-	-	-	-	-	(6)	(6)
Profit	6,998	6,232	5,789	55,149	41	-	(6)	74,202
Non-controlling interests	-	-	-	-	8	-	-	9

(*) Figures shown for the "TV publishing" segment refer to the eight-month period from 1 May 2013 to 31 December 2013.

A client in the publishing segment (the publications distributor) accounts for approximately 74% of net consolidated operating revenue.

Management monitors the operating results of business units separately in order to decide on the allocation of resources and the evaluation of results. Transfer prices between business sectors are established based on market conditions applicable in transactions with third parties.

Segment statement of financial position figures, specifically, total assets for each reportable segment, do not represent amounts regularly provided to the chief operating decision-maker. This detail, formerly prescribed also without such condition, is not provided in these explanatory notes in accordance with the amendment of IFRS 8 – *Operating segments*, effective as from 1 January 2010.

16. Earnings per share

Earnings per share are calculated dividing the financial results of the Group by the weighted average of outstanding shares, excluding the weighted average of treasury shares. Specifically:

Description	31/12/2014	31/12/2013
€ thousands		
Profit from continuing operations	23,816	74,208
Profit / (loss) from discontinued operations	(1)	(6)
Profit for the year	23,815	74,202
Weighted average number of shares outstanding	78,343,400	78,343,400
Weighted average number of treasury shares	(779)	(169,976)
Weighted average number of shares to calculate earnings per share	78,342,621	78,173,424
€ thousands		
Earnings per share attributable to continuing operations	0.304	0.949
Earnings / (loss) per share attributable to discontinued operations	(0.000)	(0.000)
Net earnings per share	0.304	0.949

Earnings per share in 2013, excluding non-recurring income and charges from the acquisition of La7 S.r.l., had amounted to Euro 0.244.

Diluted earnings per share are not calculated as there are no shares with a potential dilutive effect.

NOTES TO THE STATEMENT OF FINANCIAL POSITION

Asset and liabilities by category are analyzed in the following notes.

17. Property, plant and equipment

The movements in PPE can be analyzed as follows:

Description	Property	Plant and equipment	Other assets	Assets under development	Total
Carrying amount at 31/12/2013	1,324	195	1,310	-	2,829
Additions	-	531	161	-	692
Depreciation	(43)	(98)	(311)	-	(452)
Carrying amount at 31/12/2014	1,281	628	1,160	-	3,069

In 2014, due to the impairment of tangible assets made in 2013 in the allocation of the purchase price of the investment in La7 S.r.l. described in Note 10, lower depreciation was recognized on "property, plant and equipment" in the amount of Euro 2,794 thousand (Euro 2,208 thousand in 2013).

18. Intangible assets

The movements in intangible assets can be analyzed as follows:

Description	Television rights	Concessions, licenses and trademarks	Goodwill	Publication titles	Assets under development	Total
Net amount at 31/12/2013	992	1,087	7,198	1,277	2,432	12,986
Additions	9,752	716	-	-	36,572	47,040
Amortization	(2,215)	(675)	-	(265)	-	(3,155)
Net amount at 31/12/2014	8,529	1,128	7,198	1,012	39,004	56,871

In 2014, due to the impairment of intangible assets made in 2013 in the allocation of the purchase price of the investment in La7 S.r.l. described in Note 10, lower depreciation was recognized on "intangible assets" in the amount of Euro 15,442 thousand (Euro 14,329 thousand in 2013).

Television rights

This item includes the investments made by La7 S.r.l. in registration rights (with a duration of over 12 months) for the broadcasting of films, series and soaps.

Concessions, licenses and trademarks

At 31 December 2014, this item mainly regarded software.

Goodwill

This item refers to the excess of the purchase price over the percentage attributable to the Group of the fair value of assets, liabilities and identifiable contingent liabilities of a number of subsidiaries at their date of acquisition, net of related accumulated amortization at 30 September 2004, as the Group chose to adopt the exemption provided under IFRS 1 not to apply IFRS 3 retrospectively to transactions which took place prior to the date of transition to IFRS.

The movements in this item for each of the cash generating units (CGU), which the Group has identified for the business segments in which it operates, are described below:

Cash Generating Unit	31/12/13	Additions	Disposals	Impairment losses	31/12/14
Publishing	4,746	-	-	-	4,746
Advertising	2,289	-	-	-	2,289
Trovatore	163	-	-	-	163
Total	7,198	-	-	-	7,198

At 31 December 2014, goodwill underwent impairment testing as required by IAS 36. This test, carried out at least annually, was performed at the level of the cash generating units (CGUs) to which goodwill is allocated. The realizable value of goodwill was determined by estimating value in use calculated as the present value of the prospective cash flows from operations derived from the most recent company budgets and three-year plans.

The main assumptions made for the calculation of value in use are summarized as follows:

Cash Generating Unit	Growth rate of terminal values: 2014	Discount rate 2014	Growth rate of terminal values: 2013	Discount rate 2013
Publishing	1%	10.5%	1%	10.5%
Advertising	1%	10.5%	1%	10.5%
Trovatore	1%	10.5%	1%	10.5%

No evidence arose to indicate that the activities carried out by the CGUs subject to impairment testing could have suffered an impairment loss. Furthermore, the Group has developed a sensitivity analysis of the realizable values allocated to the three CGUs using the discount rate as the key parameter. No significant evidence of potential impairment arose from this analysis.

The estimates and the budget figures used for the determination of the recoverable amount of goodwill have been determined by Group management on the basis of both past experience and on the expectations of the development in the markets in which the Group operates, also taking account of the specific general economic environment. Management believes that the use of these estimates will have no significant impact in determining the carrying amount of goodwill, especially in the publishing and advertising sector, of which is already fully covered by the expected cash flows of 2015.

Titles

Titles include the following:

Description	31/12/13	Additions	Amortization	31/12/14
Bell'Italia	813	-	(165)	648
Bell'Europa	453	-	(89)	364
Other titles	11	-	(11)	0
Total	1,277	-	(265)	1,012

The time period deemed appropriate for the valuation of the remaining useful life of these titles has been set at 20 years for “Bell'Italia” and “Bell'Europa”. The carrying amount of the other titles, primarily “Arte” and “Antiquariato”, has also been amortized on a straight line basis over a 20 year period. The carrying amount of “Bell'Italia” and “Bell'Europa” underwent impairment testing to evaluate any impairment loss on realizable value, as defined by their value in use being cash flows based on the expected results of the titles. No evidence of impairment was identified. The main assumptions used in the calculation of value in use are the same as illustrated in the previous paragraph.

Assets under development

The increase in assets under development in 2014 is due primarily to the acquisition of the rights to use TV frequencies for digital terrestrial broadcasting systems (Euro 31.6 million plus accessory costs). On 12 April 2014, the Group company Cairo Network S.r.l. (former Cairo Sport S.r.l.) in fact applied for admission to bid in the auction opened by the Ministry of Economic Development for the awarding of the so-called L3 Lot, put up for tender with a starting price of Euro 31.6 million. This lot includes the granting of rights to use - for a period of 20 years - the 2-SFN multiplex on channels 25 and 59 ("Mux"). The L3 Lot frequencies have an estimated nominal coverage of 96.6% of the population. On 15 May 2014, the Ministry of Economic Development announced the admission of Cairo Network to the tender. On 13 June 2014, the Company submitted its binding bid and won the rights. The award was announced on 26 June 2014. On 25 July 2014, Cairo Network paid the amount of Euro 31.6 million. On 31 July 2014, the Ministry of Economic Development issued the rights of use.

The amortization of the rights to use the frequencies will start once the Mux will be ready for use. The Network Plan is expected to be completed in 12/18 months' time. As a result, at 31 December 2014, the above rights underwent impairment testing as required by IAS 36, provided for intangible assets not subject to amortization. No significant evidence of potential impairment arose from this analysis.

Assets under development includes television rights whose exploitation will begin in future years.

.

19. 19. Investments and non-current assets

The movement in this item can be analyzed as follows:

Description (€ thousands)	Carrying amount at 31/12/2013	Change in scope of consolidation	Write-ups	Impairment losses	Carrying amount at 31/12/2014
Cairo Network (former Cairo Sport S.r.l.)	10	(10)	2	(2)	-
Total subsidiaries	10	(10)	2	(2)	-
Auditel S.r.l.	46	-	-	-	46
Other	16	-	-	-	16
Total other	62	-	-	-	62
Grand total	72	(10)	2	(2)	62

In 2014, the subsidiary Cairo Network S.r.l. (former Cairo Sport S.r.l.) was consolidated. Its financial statements had not been previously consolidated, as the company was not significant because it was not operational.

Other non-current financial assets amounted to Euro 1,113 thousand at 31 December 2014 (Euro 483 thousand at 31 December 2013), Euro 743 thousand of which refer to the fair value of financial instruments to hedge exchange risks (forward currency purchases coinciding with schedules of contractual payments due) used by La7 S.r.l. to purchase TV rights from film companies. The residual amount of Euro 370 thousand (Euro 483 thousand at 31 December 2013) refers mainly to loans to La7 S.r.l. employees.

20. Deferred tax assets

These refer to the recognition, in the financial statements at 31 December 2014, of deferred tax assets on the temporary differences between the carrying amounts of recognized assets and liabilities and their tax amounts, as follows.

	31/12/2014		31/12/2013	
	Amount of temporary differences	Tax effect	Amount of temporary differences	Tax effect
Deferred tax assets				
Taxed allowance for impairment	6,893	1,896	10,525	2,896
Tax losses carried forward	-	-	15	4
Taxed and returned provisions for risk and charges	996	310	980	305
Taxed provision for inventory write-down	518	163	545	171
Directors' fees	633	174	825	227
Consolidation entries for write-off of intra-group trade relations	1,830	575	2,092	657
Different accounting treatment of post-employment benefits	2,276	626	544	150
Other temporary differences	882	284	656	206
Total deferred tax assets	14,028	4,028	16,182	4,616
Deferred tax liabilities				
Different accounting treatment of land depreciation	(143)	(45)	(86)	(27)
Total deferred tax liabilities	(143)	(45)	(86)	(27)
Net deferred tax assets	13,885	3,983	16,096	4,589

Deferred tax assets are recognized to the extent they are considered recoverable depending on the presence of future taxable income in which temporary differences will be reversed. Management periodically reviews the estimates underlying the recoverability of these amounts.

.*.*.*

21. Inventories

Inventory movements arise entirely in the publishing companies and can be analyzed as follows:

Description	31/12/14	31/12/13	Change
Raw materials, consumables and supplies	2,873	3,564	(691)
Work-in-progress and bordereau	171	166	5
Finished products and books	252	374	(122)
Total	3,296	4,104	(808)

Inventories are stated net of the provision for inventory write-down of Euro 1,032 thousand (Euro 1,032 thousand at 31 December 2013).

- **Raw materials**

Raw materials relate mainly to paper and are recognized at the lower of purchase or production cost and their estimated realizable value, based on market performance at year end.

- Work-in-progress

Work-in-progress comprises purchase or production costs incurred for publications to be invoiced by Cairo Editore S.p.A. This item also includes bordereau for services yet to be used, available for future publications, and work in progress on forthcoming editions.

- Finished products

The item includes:

- Euro 121 thousand (Euro 154 thousand at 31 December 2013) related to inventories of books of Cairo Publishing S.r.l., measured at the lower of cost and estimated realizable value;
- Euro 131 thousand (Euro 219 thousand at 31 December 2013) related to the inventories of La7 S.r.l. of TV programmes produced and awaiting to be aired at 31 December 2014, and to rights on films, soaps, cartoons and documentaries, acquired for a period of less than 12 months, whose available right has not exhausted and for which airing time during the next financial year is available.

22. Trade receivables

Trade receivables can be analyzed as follows

Description	31/12/14	31/12/13	Change
Trade receivables	89,926	104,775	(14,849)
Allowance for impairment	(9,969)	(14,710)	4,741
Total trade receivables	79,957	90,065	(10,108)

Trade receivables are stated net of the allowance for impairment that has been determined taking account of both specific collection risks and a general risk of non-collectability based on the ordinary trend of company operations. This allowance also takes into account the allocation to the Group's media clients, in particular third-party clients, of a percentage of losses on receivables, equal to the percentage of revenue allocated, pursuant to advertising space sales contracts signed between the two parties.

The ageing of trade receivables by due date at 31 December 2014 versus 31 December 2013 is as follows:

31 December 2014	Current	Past due between 30 and 60 days	Past due between 61 and 90 days	Past due between 91 and 180 days	Past due over 180 days	Total
Trade receivables	75,369	1,845	674	1,697	10,341	89,926
Allowance for impairment	(2,300)	(254)	(219)	(255)	(6,942)	(9,969)
Trade receivables	73,069	1,591	455	1,442	3,399	79,957

31 December 2013	Current	Past due between 30 and 60 days	Past due between 61 and 90 days	Past due between 91 and 180 days	Past due over 180 days	Total
Trade receivables	83,259	3,868	1,458	4,187	12,003	104,775
Allowance for impairment	(3,216)	(244)	(279)	(2,179)	(8,792)	(14,710)
Trade receivables	80,043	3,624	1,179	2,008	3,211	90,065

In terms of concentration, the top 10 customers represent roughly 12% (15% in 2013) of total advertising sales, while the top 100 customers represent 54% (58% in 2013).

The publishing segment presents a limited exposure to credit risk as publishing revenue is substantially generated by one sole party – the Group - while for distribution revenue, the distribution contract, which accounts for about 74% of net consolidated operating revenue, provides for an advance payment equal to a significant percentage of the estimated sales of each magazine.

In 2014, the allowance for impairment increased with accruals of Euro 2,757 thousand from provisions for the year. Use over the period, amounting to Euro 7,498 thousand, resulted in a net decrease of Euro 4,741 thousand.

Trade receivables include due from Torino Football Club S.p.A.: Euro 103 thousand to Cairo Pubblicità for contractual relations as described in [Note 36](#), and Euro 304 thousand to Cairo Communication for administrative services provided and for various recharged expenses.

23. Other receivables and other current assets

The item can be analyzed as follows:

Description	31/12/14	31/12/13	Change
IRAP credit	1,267	326	941
Tax receivables	1,496	1,029	467
VAT credit	1,528	2,177	(649)
Total tax assets	4,291	3,532	759
Prepayments and accrued income	1,364	1,434	(70)
Advances to suppliers	2,054	1,909	145
Other receivables	721	1,494	(773)
Total other receivables and other current assets	8,430	8,369	61

24. Securities and other current financial assets

At 31 December 2014, the Group held no securities or other current financial assets.

25. Cash and cash equivalents

The item can be analyzed as follows:

Description	31/12/14	31/12/13	Change
Bank accounts	149,042	172,833	(23,791)
Cash	19	82	(63)
Total cash and cash equivalents	149,061	172,915	(23,854)

The consolidated net financial position at 31 December 2014, versus the situation at 31 December 2013, can be summarized as follows:

Description	31/12/14	31/12/13	Change
Cash and cash equivalents	149,061	172,915	(23,854)
Bank loans	(25,000)	-	(25,000)
Total cash and cash equivalents	124,061	172,915	(48,854)

As shown in the consolidated cash flow statement, the change in the net financial position versus 31 December 2013 is mainly due to the investment made by Cairo Network in the acquisition of the Mux (Euro 31.6 million plus accessory costs), and to the distribution of dividends approved by the Shareholders' Meeting on 29 April 2014 (0.27 Euro per share, for a total of Euro 21.2 million).

The bank loan of Euro 25 million, granted by Unicredit S.p.A. and used by Cairo Network to pay the rights of use of the TV frequencies, is secured by a guarantee issued by the parent Cairo Communication,

and calls for the payment of an interest rate equal to the 3-month Euribor plus 225 basis points and certain constraints (negative pledges) and commitments (covenants) on the part of the company, which are typical of these transactions, as explained in Note 28 below.

At 31 December 2014, the net financial position of La7 came to Euro 106.5 million (Euro 115.8 million at 31 December 2013), a change attributable mainly to the dynamics of net working capital and to investments in the purchase of TV rights.

Under the contract to acquire the entire share capital of La7, entered into in April 2013, for a period of 24 months following acquisition, Cairo Communication undertakes to use the financial resources resulting from the contribution received from Telecom Italia Media in the exclusive interest of La7 and to restructure the company, and to not distribute dividends or reserves of La7.

It is Group policy to invest available cash in on-demand or short-term bank deposits, properly spreading the investments, essentially in banking products, with the prime objective of maintaining a ready liquidity of the said investments. The investment products are selected on the basis of their credit rating, their reliability and the quality of services rendered.

26. Equity

At 31 December 2014, consolidated equity was Euro 126,347 thousand, including profit for the year.

The statement of reconciliation of the Parent's equity and profit and Group equity and profit is set out in the Directors' Report.

At their Meeting on 29 April 2014, the shareholders approved the distribution of a dividend of 0.27 Euro per share, inclusive of tax. The dividend, amounting to Euro 21.2 million, was distributed with detachment date on 12 May 2014 (payable on 15 May 2014).

The share capital at 31 December 2014 was Euro 4,074 thousand, subscribed and fully paid up, comprising n. 78,343,400 ordinary shares to which no nominal amount is attributed.

In accordance with the bylaws, the shares are registered, indivisible and freely transferable. The requirements of representation, legitimization, circulation of the company investment required for securities traded on regulated markets continue to apply. Each share has the right to a proportion of the profit which has been approved for distribution and to a portion of equity on liquidation and also has the right to vote, without limits other than those as defined by the Law. No securities carrying special controlling rights have been issued. No financial instruments have been issued attributing the right to

subscribe to newly-issued shares. No share incentive plans are envisaged involving share capital increases, including bonus issues.

The reconciliation between the number of shares outstanding at 31 December 2014 and those at 31 December 2013 is as follows:

	31/12/2013	Purchase of treasury shares	Sale of treasury shares	31/12/2014
Ordinary shares issued	78,343,400	-	-	78,343,400
Less: treasury shares	(779)	-	-	(779)
Ordinary shares outstanding	78,342,621	-	-	78,342,621

In 2014, as part of the share buy-back plans, no treasury shares were sold or purchased. At 31 December 2014, Cairo Communication held a total of n. 779 treasury shares, or 0.001% of the share capital, subject to art. 2357-ter of the Italian Civil Code.

27. Post-employment benefits

This item reflects the accruals made for all employees at the reporting date on the basis of the projected unit credit method, using actuarial valuations. The main assumptions used in this valuation are as follows:

COMPANY	Cairo Communication	Cairo Pubblicità	Cairo Editore	La 7	Cairo Pubblicità
TYPE OF VALUATION	Post-empl. benefits	Post-empl. benefits	Post-empl. benefits	Post-empl. benefits	Suppl. indemnity
DATE OF VALUATION	31/12/2014	31/12/2014	31/12/2014	31/12/2014	31/12/2014
Mortality table	Sim/f 1998	Sim/f 1998	Sim/f 1998	RG48	Sim/f 1998
Reduction of mortality table	20,00%	20,00%	20,00%		20,00%
Advance request rate EXECUTIVE	1,00%	0,50%	0,50%	3,00%	-
Advance request rate MANAGER	2,00%	0,50%	2,00%	3,00%	-
Advance request rate EMPLOYEE	2,00%	0,50%	2,00%	3,00%	-
Advance request rate JOURNALIST	not present	not present	2,00%		
Salary increase rate EXECUTIVE	5,00%	2,50%	0,00%	1,69%	-
Salary increase rate MANAGER	4,00%	2,50%	0,00%	1,69%	-
Salary increase rate EMPLOYEE	4,00%	2,50%	0,00%	1,69%	-
Salary increase rate JOURNALIST	not present	not present	0,00%		
Fee increase rate AGENT	-	-	-		4%
Future inflation rate	1,69%	1,69%	1,69%	1,69%	2,00%
Discount rate	1,69%	1,69%	1,69%	1,69%	4,00%
Resignation rate EXECUTIVE	2,00%	0,50%	0,00%	X<0 4%; 41<X<50 2.5%; over 0%	-
Resignation rate MANAGER	2,00%	0,50%	5,00%	X<0 4%; 41<X<50 2.5%; over 0%	-
Resignation rate EMPLOYEE	7,00%	2,50%	6,50%	X<0 4%; 41<X<50 2.5%; over 0%	-
Resignation rate JOURNALIST	not present	not present	5,00%		
Resignation rate AGENT	-	-	-		15%

The composition and movements of this item is broken down as follows:

	31/12/2014	31/12/2013
Opening balance	11,832	4,086
Change in scope of consolidation	-	7,181
Provisions	1,203	1,102
Interest expense	354	457
Profit (loss) from actuarial valuations	991	370
Utilization/other movements	(982)	(1,364)
Closing balance	13,398	11,832

The average headcount over the two years can be analyzed as follows:

Description	31/12/2014	31/12/2013	Average
Senior managers	24	24	24
Managers	83	82	83
Employees	396	402	399
Journalists and freelance	234	229	231
Grand total	737	737	737

28. Non-current financial liabilities

The item includes the non-current portion (Euro 20,000 thousand) of the bank loan of Euro 25 million, granted by Unicredit S.p.A. in July 2014 to Cairo Network for the purchase of rights to use TV frequencies, as explained in the Directors' Report.

The loan:

- expires on 31 December 2019. Repayment is made in 20 quarterly instalments of Euro 1,250 thousand, starting from 31 March 2015; early repayment is allowed;
- is secured by a guarantee issued by the parent Cairo Communication;
- calls for the payment of an interest rate equal to the 3-month Euribor plus 225 basis points and certain constraints (negative pledges) and commitments (covenants), typical of these transactions.

Specifically:

- under the financial covenants, to be checked annually, at Group level (consolidated financial statements), the debt cover (the net debt/EBITDA ratio) should be less than or equal to 1.75 and the leverage (the net debt/equity ratio) less than or equal to 1;
- the commitment covenants on Cairo Network mainly include, until full repayment of the loan and subject to the prior consent of the bank, the commitment, (i) not to distribute nor approve the distribution of dividends and/or reserves, (ii) not to take on new financial debt (excluding loans received by the shareholders and the new debt related to the sale of receivables for working capital

needs or the issue of new insurance and bank sureties to cover ordinary needs), (iii) not to grant guarantees to third parties in the interest of Group companies or loans to Group companies, (iv) not to dispose of company assets and/or investments, (v) not to implement extraordinary corporate transactions, (vi) not to create or allow the creation of liens, pledges or mortgages on own assets.

Breach of the commitment and/or financial covenants may result in termination of the loan agreement, pursuant to Article 1456 of the Italian Civil Code. Early repayment is provided for in the event of a change of control of Cairo Network.

29. Provisions for risks and charges

The provisions for risk and charges include:

Description	31/12/2013	Increases	Utilizations	31/12/2014
Pension and similar provision	1,197	180	(52)	1,325
Provision for publishing returns	421	391	(421)	391
Provision for liquidation	64	-	-	64
Provisions for future risks and charges under the purchase price allocation of La7 S.r.l.	21,389	-	(2,337)	19,052
Provision for other risks and charges	11,911	-	(2,401)	9,510
Grand total	34,982	571	(5,211)	30,342

The provision for “pension and similar provision” was accrued by Cairo Pubblicità S.p.A. for the agents’ termination benefits as prescribed by law and contracts, subject to actuarial valuations based on the assumptions illustrated in [Note 27](#).

The “provision for publishing returns” relates to the operations of the subsidiary Cairo Publishing S.r.l.; the relating net provisions are deducted from revenue from book sales.

The provision for "liquidation charges" refers to provisions made to cover the liquidation charges of Diellesei S.r.l. in liquidation, the relevant provisions are recognized in profit/ (loss) from discontinued operations.

As mentioned earlier, under the purchase price allocation of La7 S.r.l., a negative fair value of Euro 21,389 thousand was given to:

- a) a number of contracts whose unavoidable costs of meeting contractual obligations exceed the economic benefits expected to be received;
- b) specific risk situations related to (i) existing contracts and (ii) pending litigation.

The item “Provision for other risks and charges”, amounting to Euro 9,510 thousand, includes provisions for risks and charges for pending litigation with social security institutions, leased staff and employees.

The item also includes funds for future expenses set aside to cover the risk arising from claims for damages originated during the production and airing of TV programmes and contractual terms of stability.

30. Current loans and borrowings

The item includes the current portion (Euro 5,000 thousand) of the bank loan of Euro 25 million, granted by Unicredit S.p.A. in July 2014 to Cairo Network, as explained in Note 28 above.

31. Trade payables

Trade payables amounted to Euro 87,884 thousand, decreasing by Euro 18.042 thousand versus 31 December 2013, and refer entirely to the current year.

Trade payables include Euro 1,231 thousand due to the associate Torino Football Club S.p.A. for amounts accrued under the advertising concession contract signed with Cairo Pubblicità S.p.A.

32. Receivables from and payables to the Parent

Receivables from and payables to the parent of Euro 6,539 thousand and Euro 156 thousand, respectively, refer mainly to the parent UT Communications S.p.A. and arise from the national tax consolidation scheme, under art. 117/129 of the TUIR (Consolidated income tax act), which Cairo Communication S.p.A. and its subsidiaries Cairo Editore S.p.A., Cairo Pubblicità S.p.A., Diellesei S.r.l. in liquidation, Cairo Publishing S.r.l., La7 S.r.l. and Cairo Network S.r.l. (former Cairo Sport S.r.l.) have agreed to participate in.

33. Tax liabilities

They include:

Description	31/12/2014	31/12/2013	Change
Withholding taxes on employees	2,107	2,056	51
Withholding taxes on contract workers	654	691	(37)
VAT payables	1,111	996	115
IRAP payables	1,564	-	1564
Other	51	9	42
Total tax liabilities	5,487	3,752	1,735

34. Other current liabilities

The item can be analyzed as follows:

Description	31/12/2014	31/12/2013	Change
Social security charges payables	4,826	5,659	(833)
Advances on subscriptions	1,777	1,843	(66)
Due to personnel (holidays, bonuses, etc.)	11,510	9,979	(1,531)
Accrued expenses and deferred income	768	624	144
Other liabilities	4,885	2,717	2,168
Total other current liabilities	23,766	20,822	2,944

Social security charges payables relate entirely to the current year. The Group normally pays social security charges and withholding taxes in accordance with legally defined due dates.

Advances relate to the portion of subscription payments received from customers to whom magazines have not yet been issued, as well as prepayments for specially commissioned future editions.

35. Commitments and risks

The agreements reached in the purchase of the entire share capital of La7 S.r.l. also included a multi-year agreement between La7 and Telecom Italia Media Broadcasting S.r.l. (TIMB) for the supply of transmission capacity that provides, among other things, the issue by Cairo Communication of a parent company guarantee to cover the payment obligations undertaken by La7, for a maximum amount of Euro 3,995 thousand (including VAT) until 31 December 2013, and Euro 6,558 thousand (including VAT) per year effective as from 1 January 2014.

The contract, signed on 6 March 2013 with Telecom Italia Media for the acquisition of the entire share capital of La7 S.r.l., also provides for:

- the buyer's commitment, for a period of 24 months (lock-up) from the date of finalization of the acquisition, not to sell, assign, transfer, dispose of in any way, in whole or in part, the investment in La7, or the business unit owning La7, without prejudice to the buyer's right, including during lock-up, to:
 - o undertake a transfer or assignment to entities wholly-owned, whether directly or through other companies wholly-owned by Cairo Communication;
 - o merge La7 and Cairo Due S.r.l., provided the latter, at the effective date of the merger, does not have a negative net financial position in excess of Euro 1,020 thousand;
 - o constitute real rights of guarantee in favor of the lending banks on the shares of LA7 ;

-
- undertake, under certain conditions, a proportional demerger of the group.

The lock-up commitments are accompanied by a penalty clause of the amount of Euro 20 million.

- Cairo Communication's commitment, for a period of 24 months from the date of finalization of the acquisition, to use the financial resources arising from the contribution received from Telecom Italia Media in the exclusive interest and for the restructuring of La7, and the related prohibition to engage in certain transactions specified in the contract, including of an extraordinary kind, aimed at depriving La7 of the resources from the contribution to the benefit of third parties or related parties, or to make new investments.

This commitment, as the above, is accompanied by a penalty clause, the amount of which varies depending on the transaction.

In 2014, the subsidiary Cairo Network (former Cairo Sport S.r.l.) took part in the tender procedure opened by the Ministry of Economic Development for the assignment of rights to use TV frequencies for digital terrestrial broadcasting systems, submitting its binding bid and winning the rights to use a lot of frequencies ("Mux") for a period of 20 years. In January 2015, Cairo Network and EI Towers S.p.A. ("EIT") therefore entered into the agreements for the realization and subsequent long-term technical management in full service mode (hospitality, service and maintenance, use of broadcasting infrastructure, etc.) of the Mux. The agreements provide, among other things, for:

- a transitional phase, which will see the realization and start-up of the MUX and the initial operations, which will run from the date the agreements were signed to 31 December 2017, and an operational phase of the Mux lasting 17 years (from 2018 to 2034);
- the right to free withdrawal of Cairo Network starting from 1 January 2025;
- guaranteed coverage at full performance of at least 94% of the population, in line with national Muxs with greater coverage;
- consideration to EIT:
 - during the transitional phase (2015-2017), amounting to a total of Euro 11.5 million for the full three-year period;
 - at full performance (starting from 2018), amounting to Euro 16.3 million per year.

These amounts include compensation for the availability of the transmitters;

- an annual consideration from EIT to Cairo Network, starting from 2018, ranging between Euro 0 up to Euro 4 million, in the event that the available bandwidth on the Mux is not fully used by Cairo Network.

With the acquisition and realization of the Mux, the Cairo Communication Group will start operations as a network operator.

With regard to the Automatic Numbering Plan, the numbers currently in use (7 for La7 and 29 for La7d) are those assigned by the Ministry of Economic Development in 2010, under AGCOM resolution 366/2010/CONS. The Resolution had been challenged by Telenorba and other local broadcasters, with partial annulment specifically regarding the assignment of numbers 7-8 and 9 by the Council of State through Ruling 4660/12.

On 21 March 2013, the Communications Authority (AGCOM) unanimously approved the New Automatic Numbering Plan for digital terrestrial television (LCN) by Decision 237/13/CONS. The decision confirmed, for national traditional broadcasters, the assignment of numbers 0-9 of the first block of LCN numbering (see p. 39-40 and 44 of AGCOM Decision no. 237/13/CONS).

Deeming that the New Plan evaded the Council of State's ruling (given that it confirmed assignment to the national traditional broadcasters of numbers 0-9 in the first block of LCN numbering), Telenorba filed an appeal for compliance with ruling n. 4660/12. The appeal was upheld by the Council of State (ruling no. 6021 of 16 December 2013), which declared the New Numbering Plan void (pursuant to Resolution 237/2013) for numbers from 8 to 9, and appointed a special commissioner tasked with verifying the correct assignment of numbers from 8 to 9 within 90 days from the beginning of the proceedings, which started on 24 February 2014. However, since the partial annulment of the previous Plan initially included number 7, on initiation of the procedure, the special commissioner - inappropriately in the opinion of La7 - also referred to number 7, which instead, under the Ruling, is not subject to verification by the Commissioner. AGCOM has in the meantime re-extended the previous Plan (based on current assignments), as also suggested in the State Council's ruling, in order to avoid a regulatory void.

In execution of ruling no. 6021, the Special Commissioner launched a public consultation on an outline provision named "Automatic numbering plan of digital terrestrial free-to-air and pay TV channels, procedures for allocating numbers to providers of audiovisual services authorized to broadcast audiovisual content using digital terrestrial technology and relating conditions of use". Telenorba, All Music and AGCOM have challenged the acts adopted by the Commissioner, lodging enforcement reviews and claims before the State Council (the court of compliance), arguing that the Commissioner had exceeded the requirements of sentence no. 6021 of 2013.

Following orders n. 5041, 5127 and 5859 of 2014, under which the Council of State has given the Commissioner certain regulations to discharge the task, the Commissioner adopted a new outline provision (no. 7 of 2014), accompanied by an explanatory report.

The parties to the proceedings and the Commissioner were heard in personal hearings before the President of the Panel and the Judge-Rapporteur on the assessments made by the Commissioner in the acts recently adopted.

The Commissioner has yet to complete his task (expiry is currently set on 20 May 2015), while the Council of State has yet to rule on the enforcement reviews and claims lodged by Telenorba, All Music and AGCOM.

In the opinion of La7 and its legal advisers, in light of the task discharged by the Commissioner and the orders of the State Council, further assessments by the State Council on number 7 are unlikely to be made, nor will the allocation of this number to La7 be challenged.

As the result of a VAT audit performed on Cairo Communication S.p.A., in its report, the Guardia di Finanza (the Italian Tax Police) identified some findings for 2002 and subsequent years (2003, 2004, 2005 and 2006) relating to the application if any of VAT on dealing rights charged to media centres, which were subsequently included in the final audit reports issued in January 2008 (for 2002), in June 2008 (for 2003, 2004 and 2005) and on 24 November 2011 (for 2006), which the company has challenged. The relevant hearing was held on 23 May 2014 and, to date, its judgment has yet to be filed. For all the periods in question (2002, 2003, 2004 and 2005), the Provincial Tax Commission of Milan has ruled in favour of the Company's appeals. The Agenzia delle Entrate (Italian Tax Authorities) has filed an appeal with the Regional Tax Commission of Milan against these decisions. In April 2010, the Regional Tax Commission of Milan ruled in favour of the Agency's appeal regarding 2002, and in October 2011 also regarding the years 2003, 2004 and 2005, on questionable grounds. Cairo Communication has already appealed to the Court of Cassation against the judgment regarding 2002, for which the tax claim amounts to Euro 41 thousand in addition to penalties of Euro 51 thousand, and the judgment regarding the subsequent years 2003, 2004 and 2005, for which the tax claim totals Euro 247 thousand, in addition to penalties of Euro 272 thousand and interest. The tax claim for 2006 amounts to Euro 63 thousand, in addition to penalties of Euro 79 thousand and interest. The company has also appealed against the above tax claim; the relevant hearing was held on 23 May 2014 and, to date, its judgment has yet to be filed. In June 2012, in relation to 2003, 2004, 2005 and 2006, the Company received two tax assessments demanding payment of the amounts due arising as a result of the judgment of the Regional Tax Commission, for a total claim of approximately Euro 431 thousand, including penalties and interest. In relation to the tax claim contained in these reports, based also on the advice of its tax consultants, the Directors believe there are fundamental reasons and rights to oppose the relevant findings.

In its hearing on 18 October 2010, the Provincial Tax Commission of Milan acknowledged the appeal filed by Cairo Editore S.p.A. regarding the assessment notice for tax year 2004. The Italian Tax Authorities have filed an appeal with the Regional Tax Commission of Milan against the ruling. In its hearing on 27 May 2013, the Regional Tax Commission of Milan rejected the Agency's Appeal. On 16 June 2014, the Agency filed an appeal with the Supreme Court, and on 25 July 2014, the Company notified its response to the counterparty.

A previous shareholder of the subsidiary Il Trovatore S.r.l., who did not sell its shares to the parent company, had risen a claim against the current minority shareholder, involving Cairo Communication S.p.A. indirectly, questioning the validity of the contract under which he had sold the quota in the limited partnership Il Trovatore and the transformation of this company from a limited partnership to a limited liability company (S.r.l.), and requesting the annulment of the subsequent acquisition of the company by Cairo Communication. The requests of the counterparty were rejected in the first instance, although the counterparty has filed an appeal. The case has been currently postponed to the hearing for closing arguments on 7 April 2015. Based also on the advice of its legal counsels, the Directors believe that the grounds of these claims are such as not to request a specific accrual.

Immobiledit S.r.l., the subsidiary merged into Cairo Editore in 2009, is party to a lawsuit regarding a property purchase. In 2004, the Court of Milan, in the first instance, had rejected the adverse party's claims, ordering the adverse party to pay damages, to settle in separate proceedings, and to repay legal expenses. The Court of Appeal has partly reversed the ruling of first instance, ordering Immobiledit to pay for the expenses of first and second instance, rejecting the adverse party's claim for damages, which has appealed to the Court of Cassation against the rejection. Following Ruling no. 25351/14, the Court of Cassation, rejecting all the other grounds of the main appeal of Italiana Assicurazioni, granted the first ground of appeal concerning compensation for damage suffered by Italiana Assicurazioni for the fitting-out of the property covered by the preliminary contract; the Court referred the case to the Court of Appeal of Milan, in a different formation, which will be called to review the issue of compensation for damage only on the point above; the request for compensation by Italiana Assicurazioni regarding the plea granted by the Court of Cassation amounts to approximately Euro 260 thousand. Italiana Assicurazioni shall re-open the case before the Court of Appeal of Milan by the deadline of 12 January 2016.

Guarantees given by third parties to the Cairo Communication Group amounted to Euro 323 thousand and are attributable to guarantees issued by banks.

It is also noted that:

- The consolidated financial statements at 31 December 2014 do not include any receivables or payables with a residual term exceeding five years.
- The consolidated financial statements at 31 December 2014 reflect the capitalization of financial charges of Euro 266 thousand, entered under assets under development and regarding the investments made by Cairo Network S.r.l.

36. Related party transactions

Transactions between the parent and its consolidated subsidiaries, which are its related parties, have been eliminated from the consolidated financial statements and are therefore not shown in this note.

The Group holds relations with the parent (UT Communications S.p.A.) and with the latter's subsidiaries at conditions deemed normal in their respective relevant markets, taking into account the nature of services offered. Below is a summary of the statement of financial position and income statement balances deriving from the transactions made in 2014 with these related parties. The identification and disclosure regarding related parties were made in accordance with the IAS 24 Revised.

Based on this Standard, related parties were identified as the parents, subsidiaries, associates and affiliates of the Group, as shown in the list attached to this Annual Report ("List of investments of the Group at 31 December 2014"). The Ultimate Parent of the Group is U.T. Communications S.p.A.

The effects of these relations on the consolidated statement of financial position of the Cairo Communication Group at 31 December 2014 are as follows:

Revenue and costs (€ thousands)	Operating revenue	Operating costs	Financial income	Financial charges
<u>Parent</u>				
UT Communications S.p.A.	-	-	-	-
<u>Associates</u>				
Torino FC S.p.A.	216	2,111	-	-
Total	216	2,111	-	-

In 2014, the relations and transactions with the parent U.T. Communications and with its subsidiaries can be analyzed as follows:

Receivables and financial assets (€ thousands)	Trade receivables	Other receivables and current assets	Receivables tax consolidation scheme	Other current financial assets
<u>Parent</u>				
UT Communications S.p.A.	-	-	6,539	-
<u>Associates</u>				
Torino FC S.p.A.	471	-	-	-
MP Service S.r.l.	-	47	-	-
	471	47	6,539	-

Payables and financial liabilities (€ thousands)	Trade payables	Other payables and current liabilities	Payables tax consolidation scheme	Other current financial liabilities
<u>Parent</u>				
UT Communications S.p.A.	-	-	156	-
<u>Associates</u>				
Torino FC S.p.A.	1,428	-	-	-
Total	1,428	-	156	-

In 2014, transactions with related parties, including with Group companies, were not considered to be atypical or unusual, and were part of the ordinary activities of Group companies. These transactions were carried out on market terms, taking account of the goods and services provided.

In 2014, the relations and transactions with the parent U.T. Communications and with its subsidiaries can be analyzed as follows:

- the concession contract between Cairo Pubblicità and Torino FC S.p.A. (a subsidiary of U.T. Communications) for the sale of advertising space at the Olimpico football pitch and promotional sponsorship packages. This contract resulted in the payment in 2014 of Euro 2,002 thousand to the concession holder against total revenue of Euro 2,337 thousand net of agency discounts. Cairo Pubblicità earned further commissions of Euro 65 thousand. As part of the advertising contract, Cairo Pubblicità also purchased football tickets worth Euro 109 thousand and recharged Torino F.C. pertaining costs of Euro 51 thousand;
- the agreement between Cairo Communication S.p.A. and Torino F.C. for the provision of administrative services such as bookkeeping, which provides for an annual consideration of Euro 100 thousand;
- the agreement relating to the purchase of advertising space at the Olimpico football pitch between Cairo Editore and Torino F.C., for an annual consideration of Euro 100 thousand;
- as already mentioned, Cairo Communication and its subsidiaries Cairo Editore S.p.A., Cairo Pubblicità S.p.A., Diellesei S.r.l. in liquidation, Cairo Publishing S.r.l., La7 S.r.l. and Cairo Network S.r.l. (former Cairo Sport S.r.l.) participate in the national tax consolidation scheme of UT Communications S.p.A. The consolidation scheme, which governs the financial aspects of amounts paid or received in return for the advantages or disadvantages resulting from the tax consolidation, specifically provides that any greater charges or minor benefits that may accrue to the Company resulting from participation in the scheme, be suitably remunerated by the parent. In relation to this, the consolidated financial statements at 31 December 2014 include receivables from and payables to the parent UT Communications S.p.A. of Euro 6,539 thousand and Euro 153 thousand respectively.

In 2014, Studio Magnocavallo e Associati, of which lawyer Antonio Magnocavallo is a partner, earned fees for professional services provided to companies of the Cairo Communication Group for approximately Euro 267 thousand.

Fees paid to directors in 2014 are analyzed in Note 38 “*Board of Directors’ and Board of Statutory Auditors’ fees*”.

During the year, no transactions were carried out with members of the Board of Directors, general managers and/or with key management personnel, members of the Board of Statutory Auditors, and the financial reporting manager, further than the fees paid and already shown in this Note.

The procedures adopted by the Group for related party transactions, to ensure transparency and substantial and procedural fairness, made by the Company either directly or through its subsidiaries, are illustrated in the Directors’ Report in the section on the “*Report on Corporate governance*”.

37. Risk management

Liquidity risk

The Cairo Communication Group is not exposed to liquidity risk, in that on one hand, significant financial resources are held with a net available positive financial position of Euro 124.1 million while, on the other hand, the Group attempts to ensure that an appropriate ability to generate cash is maintained, even under the current market conditions.

An analysis of the company's equity structure shows both liquidity, or the ability to maintain financial stability in the short term, and solidity, or the ability to maintain financial stability in the medium/long term.

It is Group policy to invest available cash in on-demand or very short-term bank deposits, properly spreading the investments, essentially in banking products, with the prime objective of maintaining a ready liquidity of the said investments. The investment products are selected on the basis of their credit rating, their reliability and the quality of services rendered.

Currency and interest rate risks

The Cairo Communication Group is not exposed to interest rate and currency risk, in that on one hand, there is no loan finance, whilst on the other hand operations are carried out exclusively in Italy, and revenue is generated entirely in the country and main costs are incurred in Euro. The interest rate risk only affects the yield on available cash. Specifically, with reference to the net financial position at 31 December 2014, a one percentage point reduction in the interest rate would result in a reduction in annual financial income of approximately Euro 1.2 million.

Movements in the cash flows and the liquidity of Group companies are centrally monitored and managed by Group Treasury in order to guarantee effective and efficient management of financial resources.

Given the limited exposure to both interest rate and FOREX risk, the Group limited use of financial hedging instruments, to hedge currency risk on the acquisition of TV rights from film studios.

Credit risk

The Group is exposed to credit risk, primarily in relation to its advertising sales activities. This risk is however mitigated by the fact that exposure is distributed across a large number of customers and that credit monitoring and control procedures are in place. In terms of concentration, the top 10 customers represent approximately 12% (15% in 2013) of total sales, whilst the top 100 customers represent 54% (58% in 2013). These ratios are basically in line with prior years.

The persisting uncertainty factors in the short and medium term, along with the resulting credit squeeze, may of course impact negatively the quality of credit and general payment terms.

The publishing segment, on the other hand, presents limited exposure to credit risk as publishing revenue is basically generated by one single party - the Group - while for distribution revenue, the distribution

contract provides for an advance payment equal to a highly significant percentage of the estimated sales of each magazine.

The Group's maximum theoretical exposure to credit risks at 31 December 2014 is given by the carrying amount of trade receivables and other recognized current assets totaling Euro 88.4 million (98.4 million at 31 December 2013), and by the nominal amount of guarantees given on third-party debts or commitments as indicated in Note 35.

The credit risks associated with cash and cash equivalents, with a maximum theoretical exposure of Euro 149.1 million (Euro 172.9 million at 31 December 2013), are considered irrelevant as they are deposits spread across various banks.

...

Board of Directors' and Board of Statutory Auditors' fees

The following information refers to the 2014 fees paid to Directors, Statutory Auditors, General Managers and key management personnel, also in subsidiaries, analyzed in detail in the Remuneration Report, prepared pursuant to art. 123 ter of the TUF:

Name	Position	Term of office	Term expiry date	Fees *	Benefits in kind	Bonuses and other incentives	Other fees**
Urbano R. Cairo	Chairman of the Board	Jan-Dec 2014	31/12/2016	500	16	-	510
Uberto Fornara	CEO	Jan-Dec 2014	31/12/2016	223	5	-	477
Maria Laura Cairo	Director	May-Dec 2014	31/12/2016	20	-	-	-
Stefania Petruccioli	Director	May-Dec 2014	31/12/2016	32	-	-	-
Roberto Cairo	Director	Jan-Dec 2014	31/12/2016	20	-	-	-
Marco Janni	Director	Jan-Dec 2014	31/12/2016	28	-	-	-
Antonio Magnocavallo	Director	Jan-Dec 2014	31/12/2016	34	-	-	-
Marco Pompignoli	Director	Jan-Dec 2014	31/12/2016	350	5	-	300
Roberto Rezzonico	Director	Jan-Dec 2014	31/12/2016	34	-	-	-
Mauro Sala	Director	Jan-Dec 2014	31/12/2016	32	-	-	-
Key management personnel	N/A	Jan-Dec 2014	N/A	-	15	-	1,218
Marco Moroni	Chairman Board of Statutory Auditors	Jan-Dec 2014	31/12/2016	30	-	-	25
Mariapia Maspes	Standing auditor	Jan-Dec 2014	31/12/2016	20	-	-	17
Marco Giuliani	Standing auditor	Jan-Dec 2014	31/12/2016	20	-	-	-

* Other fees, in addition to fees for the role of director (Euro 20 thousand), refer to:

- Urbano Cairo: fees pursuant to art. 2389, paragraph 3, Italian Civil Code (Euro 480 thousand);
- Uberto Fornara: fees pursuant to art. 2389, paragraph 3, Italian Civil Code (Euro 203 thousand);
- Marco Janni: fees for attendance in meetings of the Related Party Committee (Euro 8 thousand);
- Antonio Magnocavallo: fees for attendance in meetings of the Remuneration Committee and the Control and Risk Committee (Euro 14 thousand);
- Stefania Petruccioli: fees for attendance in meetings of the Remuneration Committee and Related Party Committee (Euro 12 thousand);
- Marco Pompignoli: fees pursuant to art. 2389, paragraph 3, Italian Civil Code (Euro 330 thousand);
- Roberto Rezzonico: fees for attendance in meetings of the Remuneration Committee and Control and Risk Committee (Euro 14 thousand);
- Mauro Sala: fees for attendance in meetings of the Risk and Control Committee and the Related Party Committee (Euro 12 thousand)

** Other fees refer to:

- Urbano Cairo: fees for his duties performed for Cairo Editore (Euro 500 thousand) and other companies of the Group (Euro 10 thousand).
- Uberto Fornara: gross fees as senior manager payable by Cairo Communication (Euro 300 thousand), remuneration from the non-compete agreement (Euro 67 thousand), fees for his duties performed for Cairo Pubblicità (Euro 100 thousand) and other companies of the Group (Euro 10 thousand).
- Marco Pompignoli: gross fees as senior manager payable by Cairo Communication (Euro 200 thousand), and fees for his duties performed for Cairo Pubblicità (Euro 90 thousand) and other companies of the Group (Euro 10 thousand).
- Key management personnel: gross fixed annual Group fees for a total of Euro 1,028 thousand (comprising gross remuneration as manager) and variable incentive components amounting to Euro 190 thousand.

Moreover, under Consob Communication n. DEM/11012984 of 24 February 2011, point 2.3, letters (a) and (f), it should be noted that:

- there are no agreements in place between the Parent and the directors for any indemnity in the event of resignation or unjust dismissal, or in the event their employment relationship ceases following a takeover bid;
- there are agreements in place between the Parent and Uberto Fornara, subject to non-competition commitments for 18 months following termination of his management relationship with the Parent, for payment during his relationship, starting from May 2014, of a gross annual fee of Euro 100,000. In the event of termination of employment before payment, as remuneration for the non-competition agreement, as of May 2014, of the total sum of Euro 450,000, to be considered a minimum consideration of the agreement, the Company will pay the manager the difference between such minimum amount and the amount paid until then as remuneration for the agreement.

Moreover, there are no succession plans regarding executive directors.

At 31 December 2014, key management personnel of the Cairo Communication Group was composed of:

- Giuseppe Ferrauto (Director, General Manager and manager of Cairo Editore);
- Giuliano Cesari (Executive Director and General Manager of Cairo Pubblicità) and manager of Cairo Communication;
- Marco Ghigliani (CEO, General Manager and manager of La7 S.r.l.).

To date, Cairo Communication has no stock option plans in place.

39. Transactions deriving from atypical and/or unusual or non-recurring transactions

Pursuant to Consob Communication of 28 July 2006 n. DEM/6064296, it should be noted that in 2014 the Cairo Communication Group did not engage in any atypical and/or unusual transactions as defined by the above Communication. Mention must be made that in 2013 the Cairo Communication Group finalized the acquisition of the entire share capital of La7 S.r.l.. The transaction, which is considered non-recurring by nature and relevant amount, generated non-recurring income and charges, recognized in the 2013 consolidated financial statements, respectively of Euro 57,066 thousand and Euro 1,917 thousand as discussed in Note 10 above.

For the Board of Directors
Chairman Urbano R. Cairo

Cairo Communication S.p.A.
Consolidated Financial Statements at 31 December 2014
- Appendices

APPENDIX 1

CAIRO COMMUNICATION GROUP COMPANIES

The following table lists all Cairo Communication Group companies, showing the company name, registered office, quota capital, and shares held, whether directly or indirectly, by the Parent Cairo Communication S.p.A. and by each subsidiary, the consolidation method and the list of investments, measured using the equity method.

Company	Registered office	Quota capital at 31/12/14:	% ownership	Reporting date	Business object	Consolidation method
Cairo Communication S.p.A.	Milan	4,074		31/12	Advertising	Full
Cairo Editore S.p.A.	Milan	1,043	99.95	31/12	Publishing	Full
Diellesei S.r.l. in liquidation	Milan	10	60	31/12	In liquidation	Full re assets and liabilities (*)
La 7 S.r.l.	Rome	1,020	100	31/12	TV publishing	Full from 30 April 2013
Cairo Pubblicità S.p.A.	Milan	2,818	100	31/12	Advertising	Full
Cairo Publishing S.r.l.	Milan	10	100	31/12	Publishing	Full
Il Trovatore S.r.l.	Milan	25	80	31/12	Internet	Full
Cairo Network S.r.l. (former Cairo Sport S.r.l.)	Milan	5,500	100	31/12	Network operator	Full
Edizioni Anabasi S.r.l.	Milan	10	99.95	31/12	Publishing	Full

(*) the income statement is consolidated on a single line basis in profit/(loss) from discontinued operations

APPENDIX**Information pursuant to Article 149-duodecies of Consob Issuers' regulations**

The following summary, prepared pursuant to art. 149-xii of Consob Regulations, shows the fees for the current period for auditing services and for non-audit services provided by the Audit Firm.

€ thousands	Services provided by	Fees for the year
Audit		
Parent - Cairo Communication S.p.A.		
	KPMG S.p.A.	75
Subsidiaries		
- Cairo Pubblicità S.p.A.	KPMG S.p.A.	35
- Cairo Editore S.p.A.	KPMG S.p.A.	60
- La7 S.r.l.	KPMG S.p.A.	75
- Cairo Network S.r.l. (former Cairo Sport S.r.l.)	KPMG S.p.A.	17

**CERTIFICATION OF THE CONSOLIDATED FINANCIAL STATEMENTS PURSUANT TO
ARTICLE 81 TER OF CONSOB REGULATION 11971 OF 14 MAY 1999 AND SUBSEQUENT
MODIFICATIONS AND AMENDMENTS**

1. The undersigned Urbano Roberto Cairo, as Chairman of the Board of Directors, and Marco Pompignoli, as Financial Reporting Manager of Cairo Communication S.p.A., also in accordance with art. 154 bis, paragraphs 3 and 4 of Legislative Decree n. 58 of 24 February 1998, certify:

- the adequacy of the characteristics of the Parent and
- the effective application of administrative and accounting procedures for the preparation of the 2014 consolidated financial statements.

2. We also certify that

2.1 the consolidated financial statements at 31 December 2014:

- a) have been prepared in compliance with International Financial Reporting Standards endorsed by the European Union, pursuant to EEC Regulation 1606/2002 of the European Parliament and Council, of 19 July 2002,
- b) are consistent with the accounting records and books of the Company,
- c) give a true and fair view of the financial position and results of operations of the Issuer and the companies included in the scope of consolidation;

2.2 the Directors' Report contains a reliable analysis on performance and operating results, as well as on the position of the Issuer and on the companies included in the scope of consolidation, together with a description of the principal risks and uncertainties to which they are exposed.

Milan, 13 March 2015

For the Board of Directors
Chairman

.....

(Urbano Roberto Cairo)

Financial Reporting Manager

.....

(Marco Pompignoli)

**Report of the Board of Statutory Auditors to the Shareholders' Meeting of Cairo
Communication S.p.A., pursuant to art. 153 of Legislative Decree 58/1998 and to
art. 2429 of the Italian Civil Code**

Shareholders,

pursuant to art. 2429 of the Italian Civil Code and to art. 153, paragraph 1, of Legislative Decree n. 58 of 24 February 1998, we hereby inform you that during the year ended 31 December 2014, we performed the oversight duties prescribed by law (art. 148 *et seq* of the above-mentioned Legislative Decree), taking also into account the standards of conduct recommended by the Italian Association of Public Accountants and Accounting Professionals, and the relevant instructions provided by CONSOB communications concerning corporate control and the activities of the Board of Statutory Auditors.

The above being stated, these are the results of the prescribed oversight duties performed during the year:

- we attended the Shareholders' Meetings and those of the Board of Directors held during the year, receiving from the Directors, in accordance with their obligations to report to the Board of Statutory Auditors, under art. 150, paragraph 1, of Legislative Decree n. 58/1998, timely and appropriate information on the overall business performance and outlook, and the most relevant transactions, in terms of size and nature, made by the Company and its subsidiaries;
- to the extent of our responsibilities, we gathered information on compliance with the law and bylaws, and oversaw compliance with the principles of proper governance and appropriateness of the Company's organizational structure, through direct observation, through information gathered from the managers of the departments involved, through regular exchange of information with the Audit Firm tasked with the statutory audit of the separate and consolidated financial statements, and by attending the meetings of the Control and Risks Committee, the Remuneration Committee and the Supervisory Body;
- we oversaw the operation and effectiveness of the internal control systems and the adequacy of the administrative-accounting system and, specifically, its reliability to properly illustrate operational events;

- pursuant to art. 19 of Legislative Decree n. 39/2010, which has assigned the Board of Statutory Auditors the role of "Internal Control and Audit Committee", we conducted oversight duties provided therein on: a) the disclosure of financial information; b) effectiveness of the internal control, internal audit and risk management systems; c) the statutory audit of the separate and consolidated financial statements; d) independence of the Audit Firm, through direct observation, information gathered from the managers of the departments involved, and by analyzing the results of the work performed by the Audit Firm. In such context, we took note of the quarterly audits performed by the Audit Firm to ensure that the accounts were kept on a regular basis; we received from the Audit Firm the Reports prescribed by art. 14 and by art. 19, paragraph 3, of Legislative Decree n. 39/2010, as well as the "Annual confirmation of independence", pursuant to art. 17, paragraph 9, lett. a) of the above Decree; we analyzed, again pursuant to art. 17, paragraph 9, lett. a) of the above Decree, the risks regarding independence of the Audit Firm and the measures it adopted to constrain such risks;
- we controlled the proper operation of the audit system on Group companies and the appropriateness of instructions given to them, pursuant also to art. 114, paragraph 2, of Legislative Decree n. 58/1998;
- we took note of the preparation of the Remuneration Report, pursuant to art. 123 *ter* of Legislative Decree n. 58 of 24 February 1998, and to art. 84 *quater* of CONSOB Regulations 11971/1999 ("**Issuers' Regulations**"), with no particular issues to report;
- we controlled the implementation processes of corporate governance rules provided by the Corporate Governance Code of Listed Companies issued by Borsa Italiana S.p.A., as adopted by the Company;
- we oversaw compliance of the internal procedure regarding related-party transactions with the principles contained in the Regulations approved by CONSOB through resolution n. 17221 of 12 March 2010 and subsequent amendments, and compliance with the above Regulations, pursuant to art. 4, paragraph 6;
- we verified compliance with the laws and regulations on the preparation and layout of the separate and consolidated financial statements, as well as the documents attached thereto. Specifically, the separate and consolidated financial statements are accompanied by the prescribed statements of conformity signed by the Chairman of the Board of Directors and by the Financial Reporting Manager, pursuant to art. 81-

ter of CONSOB Regulations n. 11971 of 14 May 1999 and subsequent amendments and supplements thereto;

- verified that the Directors' Report for 2014 complies with the laws and regulations, consistent with the resolutions adopted by the Board of Directors and with the facts illustrated in the separate and consolidated financial statements. The half-year report and quarterly reports were published in accordance with the law and regulations currently in force and required no comments from the Board of Statutory Auditors.

The specific indications to provide with this Report are listed below, in accordance with the provisions of the above-mentioned CONSOB Communication of 6 April 2001 and subsequent amendments:

1. We gathered information on the transactions of major equity and financial relevance made during the period, also through subsidiaries, to verify that they were made in compliance with the law and bylaws and that they were neither imprudent or such as to jeopardize the integrity of corporate assets.

In this regard, more specifically, mention must be made that on 25 June 2014, Cairo Communication completed the acquisition for Euro 31.626 million, in the tender procedure opened by the Ministry of Economic Development and through its subsidiary Cairo Network S.r.l., of the rights to use (for a period of 20 years) the lot of frequencies for digital terrestrial broadcasting systems (2-SFN multiplex indicated as L3 Lot), covering approximately 96.6% of the population.

We certify, therefore, that to the best of our knowledge, the above transactions were based on principles of proper governance and that the issues regarding potential or possible conflicts of interest were carefully assessed.

2. The characteristics of intra-group and related-party transactions put in place in 2014, the parties involved and the relating financial effects were appropriately explained in section 12 "Related-Party Transactions" of the "Report on Corporate Governance and Ownership Structure" in the Directors' Report for the separate and consolidated financial statements for the year ended 31 December 2014, to which reference is made. In this regard, the Board, in the course of its work, did not identify any atypical and/or unusual transactions made during the year with third and/or related parties. Mention must be made that, on 11 November 2010, the Board of Directors of the Company, under CONSOB Resolution n. 17221 of 12 March 2010 and subsequent amendments and supplements, had adopted new

internal procedures governing the decision-making process and the required disclosures regarding related-party transactions (the “**Procedures**”), which came into effect as from 1 January 2011.

Pursuant to art. 4, paragraph 6 of the CONSOB Regulations approved by the above resolution n. 17221/2010, we oversaw:

- i) compliance of the procedures adopted by the Company with the principles contained in the above regulations and their observance;
 - ii) fairness and correspondence of intra-group and related-party transactions with the interests of the Company.
3. In our view, the information provided by the Directors in their Report, pursuant to art. 2428 of the Italian Civil Code (Directors’ Report), regarding atypical and/or unusual transactions and ordinary transactions, under the previous point, is to be considered exhaustive and complete.
 4. KPMG S.p.A., the Audit Firm tasked with performing statutory audit, with which we held regular meetings during the year, today (3 April 2015) issued the Reports under art. 14 of Legislative Decree n. 39/2010, certifying that the separate and consolidated financial statements for the year ended 31 December 2014 are drawn up clearly and give a true and fair view of assets, liabilities, financial position, results of operations and other components of comprehensive income, changes in equity and cash flows of the Company and the Group, and certifying that the Directors’ Report and the disclosures under art. 123-*bis*, paragraph 4, of Legislative Decree n. 58/1998 are consistent with the separate financial statements of the Company and with the consolidated financial statements of the Group. These reports do not contain any issues of note or explanatory comments.
 5. In 2014, the Board received no complaints, pursuant to art. 2408 of the Italian Civil Code.
 6. In 2014, the Board received no complaints from third parties.
 7. In 2014, the Company did not assign KPMG S.p.A. additional non-recurring tasks.
 8. There are no reports of tasks assigned to subjects that are part of the “network” of the Audit Firm KPMG S.p.A..

9. In 2014, the Board issued its opinion as prescribed by law on the determination of compensation to managers holding strategic responsibilities, as established by the Board of Directors on the proposal of the Remuneration Committee.
10. In 2014, the Board of Directors met six times, the Control and Risks Committee four times and the Board of Statutory Auditors four times. The Remuneration Committee met two times in 2014, while the Related Party Committee met only once.
11. The Board of Statutory Auditors acquired knowledge and oversaw compliance with the law and bylaws and observance of the principles of proper governance, ensuring that actions decided and taken by the Directors complied with the law and bylaws, and were made in a perspective of profitability, and that they were neither imprudent nor reckless, or in potential conflict of interest or in contrast with the resolutions adopted by the Shareholders' Meeting, or such as to jeopardize the integrity of corporate assets.
12. With regard to the adequacy of the organizational structure of the Company and of the Group, the oversight duties of the Board of Statutory Auditors were performed by acquiring knowledge of the organizational structure through information gathered from each area, through meetings with the managers of the various departments and with the Audit Firm as part of a regular exchange of data and information.
13. The Board acquired knowledge and oversaw the adequacy and effectiveness of the internal control system, pursuant also to art. 19 of Legislative Decree 39/2010, through regular meetings with the Director in charge of the internal control system and with the internal audit manager, and through the presence of the Chairman of the Board of Statutory Auditors at the meetings of the Control and Risks Committee and of all the members of the Board at the meetings with the Model 231/2001 Supervisory Body.
14. The Board also oversaw the adequacy and reliability of the administrative-accounting system to properly illustrate operational events, through direct observation, through information received by the managers of the departments involved, by examining company documents and by analyzing the results of the work performed by the Audit Firm.

15. The Board controlled the operation of the control system over subsidiaries and the adequacy of the instructions given to the subsidiaries by the Company, pursuant to art. 114, paragraph 2, of Legislative Decree n. 58/98, in order for the Group companies to provide the required information to comply with statutory disclosure obligations. No exceptions were reported in this regard.
16. During the regular meetings held by the Board of Statutory Auditors with the Audit Firm, pursuant to art. 150, paragraph 3, of Legislative Decree n. 58/1998, no relevant issues emerged that need to be mentioned in this Report.
17. The Board also controlled the implementation processes of corporate governance rules prescribed by the Corporate Governance Code of Listed Companies issued by Borsa Italiana S.p.A., as adopted by the Company, reporting no reprehensible aspects;
18. With regard to the oversight duties performed as mentioned above, there were no omissions, reprehensible facts or irregularities reportable to the competent authorities and/or the supervisory boards, or worthy of mention in this Report.
19. Finally, the Board of Statutory Auditors performed its own assessments on compliance with the rules of law regarding the preparation of the draft separate financial statements and consolidated financial statements of the Group for the year ended 31 December 2014, of the relating explanatory notes and the Directors' Report attached thereto, either directly, assisted by department managers or through information received from the Audit Firm.

Specifically, it is acknowledged that the separate and consolidated financial statements of Cairo Communication S.p.A. for the year ended 31 December 2014 were prepared in accordance with the "International Financial Reporting Standards" (IFRS) issued by the International Accounting Standards Board (IASB) and approved by the European Union, and in accordance with the provisions issued in implementation of art. 9 of Legislative Decree n. 38/2005.

Based on the foregoing considerations, with regard to the oversight duties performed during the year, the Board of Statutory Auditors has no remarks to make, pursuant to art. 153 of Legislative Decree n. 158/1998, to the extent of its responsibilities, on the separate and consolidated financial statements, and on the explanatory notes and Directors' Report, agreeing with the proposal of the Board of Directors to allocate profit for the year, and with the proposal to distribute dividends, contained in the Directors' Report to

the IAS/IFRS separate financial statements of Cairo Communication S.p.A.

Milan, 3 April 2015

Board of Statutory Auditors

Marco Moroni (Chairman)

Marco Giuliani

Maria Pia Maspes

The following pages provide a list of the positions of administration and supervision held by the members of the Board of Statutory Auditors in other companies as at the issue date of the Report (Annex pursuant to art. 144 *quinquedecies* of the Issuers' Regulations).

**ANNEX TO THE REPORT OF THE BOARD OF STATUTORY AUDITORS OF CAIRO COMMUNICATION SPA
DRAWN UP PURSUANT TO ART. 153 OF LEGISLATIVE DECREE 58/98**

**List of positions held in Companies as per Book V, Title V, Chapters V, VI and VII of the Italian Civil Code
as at the issue date of the Report
(art. 144-quinquiesdecies Consob Regulations 11971/99)**

N.	Company Name	Position	Until approval of the financial statements
Marco Moroni (Chairman of the Board of Statutory Auditors)			
1	Betfair Italia Srl	Standing Auditor	30/04/2015
2	Cairo Communication Spa	Chairman of the Board of Statutory Auditors	31/12/2016
3	Cairo Editore Spa	Chairman of the Board of Statutory Auditors	31/12/2016
4	Cairo Pubblicità Spa	Chairman of the Board of Statutory Auditors	31/12/2015
5	Caseificio del Cigno Spa	Standing Auditor	31/12/2014
6	Elettrodelta Spa In Liquidazione	Standing Auditor	31/12/2014
7	La7 Srl	Standing Auditor	31/12/2015
8	Locauto Rent Spa	Standing Auditor	31/12/2015
9	Locauto Spa	Standing Auditor	31/12/2015
10	Publicitas International Spa	Standing Auditor	31/12/2015
11	Revicom Srl	Chairman of the Board of Directors	Until revocation
12	Sony Music Entertainment Italy Spa	Standing Auditor	31/03/2016
13	Ut Communications Spa	Chairman of the Board of Statutory Auditors	31/12/2016
14	SCF Consorzio Fonografici	Standing Auditor	31/12/2016
15	Fratelli Giacomel Spa	Standing Auditor	31/12/2016
16	Giacomel Group Srl	Standing Auditor	31/12/2016
17	Asscom Spa	Standing Auditor	31/12/2016
Number of positions held in issuing companies			1
Total number of positions held			17

N.	Company Name	Position	Until approval of the financial statements
Maria Pia Maspes (Standing Auditor)			
1	Cairo Communication Spa	Standing Auditor	31/12/2016
2	Cairo Pubblicità Spa	Standing Auditor	31/12/2015
3	Cairo Editore Spa	Standing Auditor	31/12/2016
4	UT Communications Spa	Standing Auditor	31/12/2016
5	Torino FC Spa	Standing Auditor	31/12/2016
6	LA7 Srl	Standing Auditor	31/12/2015
7	G.B.H Spa	Standing Auditor	31/12/2015
8	Alto Partnes SGR Spa	Standing Auditor	31/12/2015
9	Italholding Spa	Standing Auditor	31/12/2015
10	MAB Spa	Standing Auditor	31/12/2014
11	Eurofly services	Standing Auditor	31/12/2016
12	Kelly service Spa	Standing Auditor	31/12/2014
13	Aliserio Srl	Standing Auditor	31/12/2014
Number of positions held in issuing companies			1
Total number of positions held			13

N.	Company Name	Position	Until approval of the financial statements
Marco Giuliani (Standing Auditor)			
1	Cairo Communication Spa	Standing Auditor	31/12/2016
2	Ali Spa	Standing Auditor	31/08/2015
3	Banca Esperia Spa	Standing Auditor	31/12/2014
4	Banca Mediolanum Spa	Standing Auditor	31/12/2014
5	Mediolanum Fiduciaria Spa	Standing Auditor	31/12/2016
6	Belmond Investimenti Spa	Chairman of the Board of Statutory Auditors	31/12/2014
7	Belmond Italia Spa	Chairman of the Board of Statutory Auditors	31/12/2014
8	Hotel Splendido Srl	Single Statutory Auditor	31/12/2016
9	Mediolanum Gestione Fondi Spa	Standing Auditor	31/12/2015
10	Rothschild Italia Spa	Standing Auditor	31/03/2016
11	Yara Italia Spa	Standing Auditor	31/12/2014
12	Bg Italia Power Spa	Standing Auditor	31/12/2014
13	Space Spa	Standing Auditor	31/12/2015
14	Tioxide Europe Srl	Standing Auditor	31/12/2015
Number of positions held in issuing companies			1
Total number of positions held			14



KPMG S.p.A.
Revisione e organizzazione contabile
Via Vittor Pisani, 25
20124 MILANO MI

Telefono +39 02 6763.1
Telefax +39 02 67632445
e-mail it-frauditaly@kpmg.it
PEC kpmgspa@pec.kpmg.it

(Translation from the Italian original which remains the definitive version)

Report of the auditors in accordance with articles 14 and 16 of Legislative decree no. 39 of 27 January 2010

To the shareholders of
Cairo Communication S.p.A.

- 1 We have audited the consolidated financial statements of the Cairo Communication Group as at and for the year ended 31 December 2014, comprising the statement of financial position, income statement, statement of comprehensive income, statement of changes in equity, statement of cash flows and notes thereto. The parent's directors are responsible for the preparation of these financial statements in accordance with the International Financial Reporting Standards endorsed by the European Union and the Italian regulations implementing article 9 of Legislative decree no. 38/05. Our responsibility is to express an opinion on these financial statements based on our audit.
- 2 We conducted our audit in accordance with the auditing standards recommended by Consob, the Italian Commission for Listed Companies and the Stock Exchange. Those standards require that we plan and perform the audit to obtain reasonable assurance about whether the consolidated financial statements are free of material misstatement and are, as a whole, reliable. An audit includes examining, on a test basis, evidence supporting the amounts and disclosures in the financial statements. An audit also includes assessing the accounting principles used and significant estimates made by directors. We believe that our audit provides a reasonable basis for our opinion.

Reference should be made to the report dated 7 April 2014 for our opinion on the prior year consolidated financial statements, which included the corresponding figures presented for comparative purposes.

- 3 In our opinion, the consolidated financial statements of the Cairo Communication Group as at and for the year ended 31 December 2014 comply with the International Financial Reporting Standards endorsed by the European Union and the Italian regulations implementing article 9 of Legislative decree no. 38/05. Therefore, they are clearly stated and give a true and fair view of the financial position of the Cairo Communication Group as at 31 December 2014, the results of its operations and its cash flows for the year then ended.

- 4 The directors of Cairo Communication S.p.A. are responsible for the preparation of a directors' report on the financial statements in accordance with the applicable laws and regulations. Our responsibility is to express an opinion on the consistency of the directors' report and its specific section on corporate governance and ownership structure, to the extent of the information required by article 123-bis.1.c/d/f/l/m and article 123-bis.2.b of Legislative decree no. 58/98 with the financial statements to which they refer, as required by the law. For this purpose, we have performed the procedures required by the Italian Standard on Auditing 001 issued by the Italian Accounting Profession and recommended by Consob. In our opinion, the directors' report and the information required by article 123-bis.1.c/d/f/l/m and article 123-bis.2.b of Legislative decree no. 58/98 disclosed in the specific section of such report are consistent with the consolidated financial statements of the Cairo Communication Group as at and for the year ended 31 December 2014.

Milan, 3 April 2015

KPMG S.p.A.

(signed on the original)

Francesco Spadaro
Director of Audit



Cairo Communication S.p.A.
Separate financial statements at 31 December 2014



Income statement for the year ended 31 December 2014

		31 December 2014	31 December 2013
Net revenue	1	116.595.201	121.047.452
Other revenue and income	2	350.373	1.216.642
Services	3	(107.830.984)	(111.617.002)
Use of third-party assets	3	(714.694)	(677.301)
Personnel expense	4	(2.989.997)	(2.844.105)
Amortization, depreciation, provisions and impairment losses	5	(290.445)	(271.773)
Other operating costs	3	(90.540)	(180.865)
Operating profit		5.028.914	6.673.048
Net financial income	6	364.664	1.016.159
Income (loss) on investments	7	7.083.773	13.173.806
Pre-tax profit		12.477.351	20.863.013
Tax	8	(1.890.829)	(2.797.390)
Profit from continuing operations		10.586.522	18.065.623
Loss from discontinued operations	9	(656)	(4.787)
Profit for the year		10.585.866	18.060.836

Statement of comprehensive income for the year ended 31 December 2014

	31 December 2014	31 December 2013
Profit for the year	10.585.866	18.060.836
<i>Other non-reclassifiable items of the comprehensive income statement</i>		
Actuarial gains (losses) from defined benefit plans	(135.039)	(96.834)
Tax effect	37.136	26.629
Total comprehensive income	10.487.962	17.990.631



Statement of financial position

€ thousands			
Assets	Notes	31 December 2014	31 December 2013
Property, plant and equipment	10	457.417	547.958
Intangible assets	11	319.656	357.256
Investments	12	23.123.637	17.614.037
Other non-current financial assets	13	1.662.633	12.596
Deferred tax assets	14	424.421	493.402
Total non-current assets		25.987.764	19.025.249
Trade receivables	15	320.475	535.288
Receivables from parents	23	796.941	649.344
Receivables from subsidiaries	16	65.474.755	76.414.827
Other receivables and other current assets	17	1.148.087	1.055.941
Cash and cash equivalents	18	25.768.486	35.690.269
Total current assets		93.508.744	114.345.669
Total assets		119.496.508	133.370.918
Equity and liabilities		31 December 2014	31 December 2013
Share capital	19	4.073.857	4.073.857
Share premium reserve	19	41.062.091	44.153.763
Retained earnings	19	396.167	494.071
Other reserves	19	1.056.508	1.056.508
Treasury shares	19	(2.352)	(2.352)
Profit for the year	19	10.585.866	18.060.836
Total equity		57.172.137	67.836.683
Post-employment benefits	20	1.220.793	1.008.145
Provisions for risks and charges	21	264.181	337.382
Total non-current liabilities		1.484.974	1.345.527
Trade payables	22	2.147.470	3.604.153
Payables to subsidiaries	24	55.516.346	58.253.282
Tax liabilities	25	1.291.289	227.066
Other current liabilities	26	1.884.292	2.104.206
Total current liabilities		60.839.397	64.188.707
Total liabilities		62.324.371	65.534.234
Total equity and liabilities		119.496.508	133.370.918



Cash flow statement

€ thousands	2014	2013
CASH AND CASH EQUIVALENTS	35.690	45.426
OPERATING ACTIVITIES		
Profit	10.586	18.061
Amortization, depreciation, provisions and impairment losses	290	272
Impairment losses on investments	201	357
Net financial income	(7.649)	(14.547)
Income tax	1.891	2.797
Change in post-employment benefits	213	150
Net change in provisions for risks and charges	(73)	188
Cash flow from operating activities before changes in working capital	5.458	7.278
(Increase) decrease in trade and other receivables	17.308	9.182
Increase (decrease) in trade and other payables	(4.414)	(14.697)
TOTAL CASH FLOW FROM OPERATING ACTIVITIES	18.352	1.763
Income tax paid	(905)	(2.649)
Financial expense paid	(141)	(121)
TOTAL NET CASH FROM OPERATING ACTIVITIES (A)	17.306	(1.007)
INVESTING ACTIVITIES		
(Acquisition) net disposals of PPE and intangible assets	(162)	(499)
Interest and financial income received	506	1.512
Dividends received	1.039	3.402
Net increase in other non-current assets	(7.361)	(3.553)
NET CASH USED IN INVESTING ACTIVITIES (B)	(5.978)	862
FINANCING ACTIVITIES		
(Acquisition) disposal of treasury shares	0	1.383
Re-measurement of defined benefit plans inclusive of tax effect	(98)	(70)
Dividends paid	(21.152)	(10.905)
NET CASH USED IN FINANCING ACTIVITIES (C)	(21.250)	(9.592)
NET CASH FLOW OF THE YEAR (A) + (B) + (C)	(9.922)	(9.737)
NET CASH AND CASH EQUIVALENTS CLOSING BALANCE	25.768	35.690



Statement of changes in equity

€ thousands	Share capital	Share premium reserve	Retained earnings	Other reserves	Treasury shares	Interim dividend	Profit for the year	Equity
Balance at 31 December 2011	4.074	48.288	494	1.057	(1.132)	(11.696)	19.258	60.343
Allocation of profit			19.258				(19.258)	0
Dividend distribution		(4.134)	(19.258)			11.696		(11.696)
Interim dividend 2012						(10.126)		(10.126)
Purchase of treasury shares					(214)			(214)
Profit for the year							21.062	21.062
Balance at 31 December 2012	4.074	44.154	494	1.057	(1.346)	(10.126)	21.062	59.369
Allocation of profit			21.062				(21.062)	0
Dividend distribution			(21.031)			10.126		(10.905)
Actuarial gains (losses) from defined benefit plans			(70)				70	0
Disposal of treasury shares			39		1.344			1.383
Total comprehensive income for the year							17.991	17.991
Balance at 31 December 2013	4.074	44.154	494	1.057	(2)	0	18.061	67.837
Allocation of profit			18.061				(18.061)	0
Dividend distribution		(3.092)	(18.060)					(21.152)
Actuarial gains (losses) from defined benefit plans			(98)				98	0
Total comprehensive income for the year							10.488	10.488
Balance at 31 December 2014	4.074	41.062	397	1.057	(2)	0	10.586	57.173



Income statement pursuant to Consob Resolution n. 15519 of 27 July 2006

	31 December 2014	Related parties	% of total	31 December 2013	Related parties	% of total
€ thousands		*			*	
Net revenue	116.595.201	116.562.327	100,0%	121.047.452	121.003.937	100,0%
Other revenue and income	350.373	230.804	65,9%	1.216.642		
Services	(107.830.984)	(101.938.194)	94,5%	(111.617.002)	(104.757.536)	93,9%
Use of third-party assets	(714.694)			(677.301)		
Personnel expense	(2.989.997)			(2.844.105)		
Amortization, depreciation, provisions and impairment lo	(290.445)			(271.773)		
Other operating costs	(90.540)			(180.865)		
Operating income	5.028.914			6.673.048		
Net financial income	364.664	983	0,3%	1.016.159	1.192	0,1%
Income (loss) on investments	7.083.773	7.083.773	100,0%	13.173.806	13.173.806	100,0%
Pre-tax profit	12.477.351			20.863.013		
Tax	(1.890.829)			(2.797.390)		
Profit from continuing operations	10.586.522			18.065.623		
Loss from discontinued operations	(656)			(4.787)		
Profit for the year	10.585.866			18.060.836		

(*) Related party transactions are analyzed in Note 28



Statement of financial position pursuant to Consob Resolution no. 15519 of 27 July 2006

€ thousands						
Assets	31 December 2014	Related parties	% of total	31 December 2013	Related parties	% of total
		*			*	
Property, plant and equipment	457.417			547.958		
Intangible assets	319.656			357.256		
Investments	23.123.637	23.123.637	100,0%	17.614.037	17.614.037	100,0%
Receivables from subsidiaries	-			0		
Non-current financial assets	1.662.633			12.596		
Deferred tax assets	424.421			493.402		
Total non-current assets	25.987.764			19.025.249		
Trade receivables	320.475	303.750	94,8%	535.288	302.750	56,6%
Receivables from parents	796.941	796.941	100,0%	649.344	649.344	100,0%
Receivables from subsidiaries	65.474.755	65.474.755	100,0%	76.414.827	76.414.827	100,0%
Other receivables and other current assets	1.148.087			1.055.941		
Cash and cash equivalents	25.768.486			35.690.269		
Total current assets	93.508.744			114.345.669		
Total assets	119.496.508			133.370.918		
Equity and liabilities	31 December 2014			31 December 2013		
Share capital	4.073.857			4.073.857		
Share premium reserve	41.062.091			44.153.763		
Retained earnings	396.167			494.071		
Other reserves	1.056.508			1.056.508		
Treasury shares	(2.352)			(2.352)		
Interim dividend	0			0		
Profit for the year	10.585.866			18.060.836		
Total equity	57.172.137			67.836.683		
Post-employment benefits	1.220.793			1.008.145		
Provisions for risks and charges	264.181	128.602	48,7%	337.382	127.645	37,8%
Total non-current liabilities	1.484.974			1.345.527		
Trade payables	2.147.470	16.554	0,8%	3.604.153	16.554	0,5%
Payables to subsidiaries	55.516.346	55.516.346	100,0%	58.253.282	58.253.282	100,0%
Taxes payable	1.291.289			227.066		
Other current liabilities	1.884.292			2.104.206		
Total current liabilities	60.839.397			64.188.707		
Total liabilities	62.324.371			65.534.234		
Total equity and liabilities	119.496.508			133.370.918		

(*) Related party transactions are analyzed in Note 28



Statement of cash flows pursuant to Consob Resolution no. 15519 of 27 July 2006

€ thousands	31 December 2014	related parties	31 December 2013	related parties
CASH AND CASH EQUIVALENTS	35.690		45.426	
OPERATING ACTIVITIES				
Profit	10.586	21.940	18.061	29.403
Amortization, depreciation, provisions and impairment losses	290		272	
Impairment losses on investments	201	201	357	7
Net financial income	(7.649)	(7.284)	(14.547)	(13.156)
Income tax	1.891		2.797	
Change in post-employment benefits	213		150	
Net change in provisions for risks and charges	(73)	(1)	188	22
Cash flow from operating activities before changes in working capital	5.458	14.856	7.278	16.276
(Increase) decrease in trade and other receivables	17.308	10.791	9.182	(3.827)
Increase (decrease) in trade and other payables	(4.414)	(2.737)	(14.697)	54.819
TOTAL CASH FLOW FROM OPERATING ACTIVITIES	18.352	22.910	1.763	67.268
Income tax paid	(905)		(2.649)	
Financial expense paid	(141)		(121)	
TOTAL NET CASH FROM OPERATING ACTIVITIES (A)	17.306	22.910	(1.007)	67.268
INVESTING ACTIVITIES				
(Acquisition) net disposals of PPE and intangible assets	(162)		(499)	
Interest and financial income received	506		1.512	
Dividends received	1.039	1.039	3.402	3.402
Net increase in other non-current assets	(7.361)		(3.553)	386
NET CASH USED IN INVESTING ACTIVITIES (B)	(5.978)	1.039	862	3.788
FINANCING ACTIVITIES				
(Acquisition) disposal of treasury shares	0		1.383	
Re-measurement of defined benefit plans inclusive of tax effect	(98)		(70)	
Dividends paid	(21.152)		(10.905)	
NET CASH USED IN FINANCING ACTIVITIES (C)	(21.250)	0	(9.592)	0
CASH FLOW OF THE YEAR (A)+(B)+(C)	(9.922)	23.949	(9.737)	71.056
NET CASH AND CASH EQUIVALENTS CLOSING BALANCE	25.768		35.690	



NOTES TO THE SEPARATE FINANCIAL STATEMENTS AS AT AND FOR THE YEAR ENDED 31 DECEMBER 2014

Main activities

Cairo Communication S.p.A. is a joint-stock company listed in the Milan Company Register.

The Cairo Communication Group operates as a publisher of magazines and books (Cairo Editore – and its division Editoriale Giorgio Mondadori – and Cairo Publishing), as television editor (La7), as a multimedia advertising broker selling advertising time and space on television, in print media and in stadiums (Cairo Communication and Cairo Pubblicità), as a publisher of electronic content (Il Trovatore), and network operator (Cairo Network S.r.l.).

As explained in the Directors' Report, in 2014 the subsidiary Cairo Network S.r.l. (former Cairo Sport S.r.l.) took part in the tender procedure opened by the Ministry of Economic Development for the assignment of rights to use TV frequencies for digital terrestrial broadcasting systems, submitting its binding bid and winning the rights to use a lot of frequencies ("Mux") for a period of 20 years. In January 2015, Cairo Network and EI Towers S.p.A. entered into the agreements for the realization and subsequent long-term technical management in full service mode (hospitality, service and maintenance, use of broadcasting infrastructure, etc.) of the Mux. With the acquisition and realization of the Mux, the Cairo Communication Group started operations as a network operator.

The registered offices are at 56 Via Tucidide, Milan, home also to the administrative offices, the advertising brokerage services and Il Trovatore and Cairo Network. The publishing business is managed at Cairo Editore, at 55 Corso Magenta, Milan. The publishing business of La7 is managed mainly in Rome at the registered offices and the TV studios of La7 S.r.l. at 229 Via della Pineta Sacchetti and 32 Via Novaro, respectively.

The income statement and the statement of financial position are presented in euro, while the statement of cash flows, the statement of changes in equity and the amounts in these notes are presented in thousands of euro.

As the Parent, Cairo Communication S.p.A. has also prepared the consolidated financial statements of the Cairo Communication Group at 31 December 2014.

Basis of preparation

Structure, form and content of the financial statements

The separate financial statements of Cairo Communication S.p.A. at 31 December 2014 have been prepared in accordance with IFRS issued by the International Accounting Standard Board ("IASB") and endorsed by the European Union, as well as with the provisions arising from art. 9 of Legislative Decree no. 38/2005. The term IFRS is used to mean all the international accounting standards ("IAS"), and all the interpretations of the International Financial Reporting Interpretations Committee ("IFRIC"), formerly the Standing Interpretations Committee ("SIC").



For completeness of information, the following annexes are supplied as an integral part of these Notes:

- Annex 1: List of investments in subsidiaries and associates;
- Annex 2 and 3: Summary figures of the draft financial statements of subsidiaries at 31 December 2014;
- Annex 4 and 5: Summary figures of the most recently approved financial statements of subsidiaries.

The main accounting policies adopted are unchanged from those used for the previous year, and are shown below.

The separate financial statements are prepared on a going concern basis. The Company believes that even in the presence of a difficult economic and financial situation, significant uncertainties do not exist (as defined by paragraphs 25 and 26 of IAS 1) as to the Company's ability to continue as a going concern, also given both the profitability outlook of the Company and the Group and of its financial position.

Financial statements schedules

The **income statement** is presented by nature, highlighting interim operating results and pre-tax results, and, in order to allow a better measure of ordinary operating management performance. Furthermore, cost and revenue components deriving from events or transactions which, by their nature or size, are considered non-recurring, are also separately identified in the financial statements and the notes. These transactions also fall under the definition of non-recurring events and transactions as per Consob Communication No. 6064293 of 28 July 2006.

The economic effects of discontinued operations are shown in a single line of the income statement entitled "Profit/loss from discontinued operations" under IFRS 5.

The **statement of comprehensive income** also reflects the "*changes arising from transactions with non-owners*"- separately showing the relevant tax effects, that is:

- profit and loss that could be directly recognized in equity (for instance, actuarial losses from the measurement of defined benefit plans);
- the effects of the measurement of derivative instruments hedging future cash flows;
- the effects of the measurement of "available-for-sale financial assets";
- the effects arising from any change in accounting standards.

The consolidated statement of comprehensive income presents the items relating to the amounts of the components of other comprehensive income for the period by nature and grouped into those which, in accordance with the provisions of other IAS/IFRS:

- will not be subsequently reclassified to profit (loss) for the year;



-
- will be subsequently reclassified to profit (loss) for the year, when certain conditions are met.

The **statement of financial position** presents separately assets and liabilities divided in current and non-current, indicating, on two separate lines, “Assets intended for sale” and “Liabilities associated with discontinued operations”, in accordance with IFRS 5. Specifically, an asset or a liability is classified as current when it satisfies one of the following criteria:

- it is expected to be realized or settled or it is expected to be sold or utilized in the normal operating cycle of the company;
- it is held principally to be traded;
- it is expected to be realized or settled within 12 months of the reporting date.

Otherwise, the asset or liability is classified as non-current.

The **statement of cash flows** has been prepared applying the indirect method in which operating performance is adjusted to reflect transactions of a non-monetary nature, for whatever deferral or accrual of previous or future operating receipts or payments and for revenue or cost components connected to cash flows arising from investing or financing activities. Income and expense relating to medium or long-term financial operations and those relating to hedging instruments and dividends paid are included in financing activities.

The **statement of changes in equity** shows the variations in equity relating to:

- allocation of profit for the year;
 - amounts relating to transactions with owners (purchase and sale of treasury shares);
- and separately income and expense defined as “*changes arising from transactions with non-owners*”, also shown in the statement of comprehensive income.

For each significant item detailed in the above-mentioned schedules, reference is made to the following notes in which relevant information is provided, with details also on composition and variations on the previous year.

Furthermore, in order to comply with Consob Resolution No. 15519 of 27 July 2006 relating to financial statements schedules, specific additional statement of comprehensive income and statement of financial position have been prepared, showing material balances or related party transactions separately for each item.

Revenue and cost recognition

Revenue and cost and income and expense are recognized on an accruals basis, specifically:

- Revenue is recognized on the probability with which the company will enjoy the economic benefits and in the extent to which the amount can be reliably determined. Revenue is stated net of any adjustments.
- Advertising revenue is recognized at the moment the advertisement is broadcast or published or provision of services offered.



-
- Cost is recognized using the same criteria for revenue recognition and on an accruals basis.
 - Interest income and expense are recognized on an accruals basis.
 - Dividends are recognized only as from when the shareholders' right to the dividend payment has been established, and only when resulting from a profit distribution following the acquisition of the investment; in the case, however, of a profit distribution prior to the acquisition of their relevant shares, such dividends are treated as a reduction in the cost of the relevant investment.
 - The recharges of costs incurred on behalf of third parties are recognized as a reduction in the cost to which they relate.
 - Financial income and expense are recognized in the income statement on a maturity basis, as a function of time, using the effective interest method.

Taxes

Taxes for the year correspond to the sum of current and deferred taxes.

Current taxes are based upon taxable income for the year. Taxable income differs from the results shown in the income statement as it excludes both positive and negative entries which would be taxable or deductible in other tax years and excludes components which are not taxable or deductible at any time.

Cairo Communication and its subsidiaries Cairo Editore S.p.A., Cairo Pubblicità S.p.A., Diellesei S.r.l. in liquidation, La7 S.r.l., Cairo Network S.r.l. (former Cairo Sport S.r.l.) and Cairo Publishing participate in the national tax consolidation scheme of UT Communications S.p.A., in accordance with art. 117/129 of the Consolidated Income Tax Act.

The consolidation scheme, which regulates economic aspects pertaining to the sums deposited or calculated against the advantages or disadvantages arising from the national tax consolidation scheme, also allows for any increased costs or decreased benefits incurred by the Companies, by participating in this procedure, to be repaid by the Parent U.T. Communications S.p.A.

UT Communications S.p.A. acts as the tax parent and determines a single taxable base for the group of companies that adheres to the national tax consolidation scheme, which thereby benefits from the ability of offsetting taxable profits against taxable losses in one tax return.

Each company that participates in the national tax consolidation scheme transfers its taxable profit or loss to the tax parent. For any such taxable profit reported by a subsidiary, UT Communications S.p.A. recognizes receivables equal to the IRES payable. Conversely, for any such taxable loss, reported by a subsidiary, UT Communications S.p.A. recognize a payable equal to IRES due on the loss that has been contractually transferred at Group level.

Deferred tax liabilities are generally recognized for all taxable temporary differences, while deferred tax assets are recognized to the extent of the probability that there will be future taxable profits which will allow for the utilization of the deductible temporary differences. Deferred taxes are calculated



on the basis of the tax rates that are foreseen will be in force at the moment of realization of the asset or settlement of the liability, based on tax legislation in force at the reporting date. Where relevant, the effects of any changes in tax rate or tax legislation after the reporting date are disclosed in the notes. Deferred tax assets and liabilities are reported at their net value when there is a legal right to offset current tax liabilities and assets and when the taxes relate to the same taxation authority.

Post-employment benefits

For Italian companies with at least 50 employees, post-employment benefits take the form of a defined benefit plan, solely for the amounts accrued prior to 1 January 2007 (and not yet paid at the reporting date), whereas subsequent to such date, they are recognized as a defined contribution plan. For Italian companies with less than 50 employees, post-employment benefits are considered as a defined benefit plan. All defined benefit plans are discounted.

The Company has less than 50 employees. The discounting process, based on demographic and financial assumptions, is performed by independent actuaries.

In accordance with IAS 19 - *Employee Benefits*, the recognition of expenses related to work performed and net financial charges are recognized in the income statement, while actuarial gains and losses arising from the re-measurement of liabilities and assets are recognized in the statement of comprehensive income.

Non-current assets

Intangible assets

Costs, including accessory costs incurred for the acquisition of resources with no physical substance are recognized among intangible assets when the cost is quantifiable and the asset is clearly identifiable and controlled by the Company, and where the use of the asset will generate probable future benefits.

These are valued at their acquisition or production cost, including related costs – to the extent to which they are considered to have a finite life – and they are amortized to reflect their remaining useful economic lives.

The amortization periods of intangible assets of various types are as follows:

Concessions, licenses, trademarks and similar rights 3 to 5 years

Software 3 to 5 years

The remaining useful life and the amortization criteria applied are reviewed on a regular basis and where change is deemed necessary, the amortization rate is restated in accordance with the “prospective” method.



Property, plant and equipment

Property, plant and equipment (PPE) are recognized when their cost can be reliably determined and when related future economic benefits can be enjoyed by the Company.

They are recognized at acquisition price or production cost, including directly associated expenses and costs, plus the share of indirect costs which can be reasonably attributed to the asset.

These assets are systematically depreciated on a straight-line basis each year at rates consistent with the economic and technical useful life of the assets. Depreciation rates applied are as follows:

Property	3%
General equipment	20%
Motor vehicles	20%-25%
Plant and machinery	10%
Office equipment and furniture	10%-12%
Electronic equipment	20%

The above PPE depreciation rates are reduced by 50% during their first year of use, this percentage representing the weighted average of the entry to use of new assets, on an annual basis. Depreciation begins when the asset is ready for use.

The remaining useful life and the amortization criteria applied are reviewed on a regular basis and where change is deemed necessary, the amortization rate is restated in accordance with the “prospective” method.

The remaining useful lives of assets are reviewed annually and if incremental maintenance or other work has been carried out which changes the remaining useful life of the investment, these are adjusted accordingly.

Incremental maintenance and other costs producing a significant and tangible increase in the productive capacity or security of assets, or lengthening its remaining useful life, are capitalized and recognized as an increase in the carrying amount of the assets. Ordinary maintenance costs are taken directly to profit and loss.

Leasehold improvements are recognized as PPE, on the basis of the cost incurred. The depreciation period corresponds to the lower of the remaining useful life of the asset and the term of the contract.

Impairment of assets

At least once a year, the company reviews the recoverability of the carrying amount of its intangible assets with an indefinite useful life, and of its investments and whenever there are potential indicators of an impairment loss on PPE and intangible assets with a finite useful life, in order to determine



whether such assets may have suffered an impairment loss. When such indications are present, the carrying amount of the asset is reduced to reflect recoverable amount. The recoverable amount of an asset is the greater of its fair value less costs to sell, and its value in use. The fair value of a listed investment is determined according to its market price. To determine an asset's value in use, the Company calculates the present value of future estimated cash flows, inclusive of tax, by applying a pre-tax discount rate which reflects the current market valuation of the time value of money and the specific risks inherent to the asset.

Excluding goodwill, when the impairment loss of an asset no longer applies or is reduced, the carrying amount of the asset is increased up to the new estimated recoverable amount, which may not exceed the amount which would have been determined had no impairment loss been recognized.

Investments

Subsidiaries and associates

Investments in subsidiaries and associates are recognized at purchase or subscription cost and adjusted for any impairment loss.

Any excess in value between the purchase price at the time of acquisition and the company's share of equity at current values is therefore included in the carrying amount of the investment.

Investments in subsidiaries and associates are subject to impairment testing at least once a year, or more frequently if deemed necessary. Whenever there is evidence that such investments have incurred an impairment loss, the impairment loss is recognized in profit and loss. Should the company's share of losses in an investment exceed the carrying amount of the investment, and the company is obliged to reflect those losses, the value of the investment is written off and the share of any such losses is shown as a provision in liabilities. Whenever an impairment loss is reduced or ceases to exist, the loss is reversed up to the original carrying amount through profit and loss.

Receivables from subsidiaries and associates

Non-interest bearing loans granted to subsidiaries and associates are classified as non-current financial assets.

Current assets and liabilities

Receivables

Trade and other current assets are recognized at their estimated realizable value.

Financial assets

They are initially recognized at fair value, which basically corresponds to consideration paid and direct expenses associated with their acquisition. Financial assets acquired and sold are recognized at their trading date, when the Company intends to acquire/sell these assets.



At the subsequent reporting dates, the financial assets that the Company has the intention and the ability to hold to maturity (held-to-maturity investments) are recognized at amortized cost, net of any impairment losses, to reflect write-downs, if any.

Investments other than those held to maturity are classified as held for trading or available for sale and are measured at the end of each reporting period at their fair value. When financial assets are held for trading, gains and losses arising from fair value changes are recognized in profit and loss. In the case of available-for-sale financial assets, gains and losses arising from fair value changes are recognized in comprehensive income. When available-for-sale financial assets are sold, redeemed or transferred, cumulative gains or losses previously recognized in comprehensive income must be reclassified from equity to profit/ (loss) for the year. This reserve is also used if alignment to fair value results in subsequent impairment of the asset until the reserve is used up. Any additional loss exceeding the reserve, should it result in an impairment loss, is taken to profit and loss.

Regarding measurement of available-for-sale assets, the directors have chosen as impairment indicators the reduction in fair value below cost of over 50%, or for a period exceeding 24 months.

Cash and cash equivalents

This item comprises cash, bank current accounts and deposits on demand, and other short-term highly liquid financial investments which are easily convertible to cash and not subject to the risk of significant value changes.

They are recognized at their nominal amount.

Borrowings, bank loans and overdrafts

Borrowings, interest-bearing bank loans and bank overdrafts are recognized based on the amount cashed net of transaction costs, and subsequently measured at amortized cost using the current interest rate method.

Trade payables

They are recognized at their nominal amount.

Provisions for risks and charges

Provisions for risks and charges are recognized when the company has a legal or constructive obligation resulting from a past event and for which a probability exists for the fulfillment of that obligation. The provisions reflect the best estimate based on information currently available to the Directors of the costs required to fulfill the obligation at the reporting date, and are discounted when the effect is significant.



Treasury shares

Treasury shares are recognized as a reduction in equity. The effects of any subsequent transactions are also recognized directly in equity.

Dividends paid

Dividends payable are recorded as a movement in equity in the year they are approved by the Shareholders' Meeting or by the Board of Directors in the event of interim dividend.

Use of estimates

The preparation of the financial statements and the notes thereto, in application of the IFRS, requires that the Company carry out certain estimates and assumptions which affect the carrying amount of assets and liabilities and disclosures about assets and contingent liabilities at the reporting date. Estimates and assumptions used are based on experience and on other factors considered significant. Actual results could differ from these estimates. Estimates mainly relate to provisions for risks relating to receivables, investment measurement, depreciation, amortization, impairment of assets, taxation, provisions for risks and charges, and contingent liabilities.

Estimates and assumptions are reviewed regularly and the effects of each variation therein are recognized in profit and loss in the period in which the estimate was revised. The effects of such revisions are reflected in the periods on which they have effect, i.e. both in the current period, and in future periods, if relevant. In this context, the persisting uncertainty factors in the short and medium economic term, which make it hard to predict a return to normal market conditions, have led to the need to make assumptions regarding future performance which are influenced by significant uncertainty, and the possibility of achieving results different from those estimated cannot be excluded for the next year, which could therefore require adjustments to the carrying amount, even significant, although these are obviously neither currently quantifiable nor foreseeable.

The items most susceptible to these uncertainties are the allowance for impairment, inventory write-downs, non-current assets (intangible assets, property, plant and equipment and investments), post-employment benefits and deferred tax assets.

A summary follows of all critical measurement processes used and key assumptions made by Management regarding the future in the process of applying accounting policies and that could have a significant effect on the amount recognized in the consolidated financial statements and for which there is a risk that significant adjustments to the carrying amount of assets and liabilities could arise in the next period.



Allowance for doubtful accounts

The allowance for doubtful accounts reflects Management's estimate regarding the losses on portfolio of receivables from end customers. The allowance is estimated based on the losses expected by the Company, based upon past experience for similar receivable, current and past due dates, losses and receipts arising from the careful monitoring of receivables management and from projections on market and economic conditions. The persisting uncertainty factors in the short and medium economic term, along with the resulting credit squeeze, could result in further deterioration of the financial conditions of Company debtors compared to deterioration already considered in the quantification of the recognized allowance for impairment.

Deferred tax assets

Deferred tax assets are recorded to the extent to which it is considered probable that future taxable income will be generated to allow the utilization of different deductible temporary differences. The realizable value of deferred tax assets is periodically reviewed according to the future taxable income foreseen in the Company's most recent plans.

Recoverable amount of non-current assets

Non-current assets include investments, property, plant and equipment, intangible assets, deferred tax assets and other financial assets. Management periodically reviews the carrying amount of the non-current assets held and used, and those of assets held for sale, as and when circumstances require such revision. This is performed using the estimated cash flows expected from the use or sale of the asset and suitable discount rates to calculate present value. When the carrying amount of a non-current asset has suffered an impairment loss, the Company recognizes an impairment loss equal to the positive difference between the greater of the carrying amount of the asset and its recoverable amount from its use or sale, as determined according to the Company's most recent plans.

For the preparation of the financial statements at 31 December 2014, and in particular in the performance of impairment tests on intangible and assets and property, plant and equipment, the different sectors of the Cairo Communication Group have taken into account the expected 2015 performance, whose assumptions and results are in line with the information disclosed in the section on "*significant events after the reporting period and business outlook*". In addition, for the subsequent years of the plan, necessary adjustments have been cautiously made to take account of the deep market changes resulting from the current economic and financial crisis. No significant impairment was required based on such figures in the plan.



Provisions for risks and charges

The provisions for risks and charges relating to contingent liabilities of a legal or fiscal nature are made on the basis of estimates made by the Directors on the basis of valuations made by the Company's legal counsels and fiscal advisors on the probable charge that can be reasonably expected to fulfill the obligation.

Risk management

The main fiscal, legal and financial risks to which Cairo Communication S.p.A. is exposed, as well as the policies put in place by Management for their management, are explained in Note 28 and Note 30. Reference is made to the Directors' Report regarding operational and business risks.

Accounting standards, amendments and interpretations applied from 1 January 2014

The following accounting standards, amendments and interpretations, revised also following IASB's yearly improvement process, were applied for the first time starting from 1 January 2014:

- **IFRS 10 – Consolidated Financial Statements** - The standard, issued by the IASB in May 2011, supersedes SIC 12 - *Consolidation: special purpose entities (vehicles)* and parts of IAS 27 – *Consolidated and separate financial statement*, renamed *Separate financial statements*. It sets out the accounting requirements of equity investments in the separate financial statements. IFRS 10 introduces a new control model that is applied to all entities, including vehicles, based on the power exercised by the Group over these entities, exposure or rights to variable returns from its involvement with these entities, and the ability to use its power to influence these variable returns. The IASB requires retrospective application of the standard from 1 January 2013. The competent EU bodies have completed the approval process of the standard, deferring the date of application to 1 January 2014, allowing however early adoption beginning from 1 January 2013.

The adoption of the new standard did not require the redefinition of the scope of consolidation.

- **IFRS 11 – Joint arrangements** – The standard, issued by the IASB in May 2011, supersedes IAS 31 – *Interests in Joint Ventures* and SIC 13 – *Jointly controlled entities - Nonmonetary contributions by venturers* IFRS 11 provides criteria to identify joint arrangements based on the rights and obligations arising from the agreements, rather than on their legal form. It uses only the equity method to account for interests in joint ventures in the consolidated financial statements. Following issue of this standard, IAS 28 – *Investments in associates* was amended to include within its framework, from the effective date of the standard, interests in joint ventures. The IASB requires retrospective application of the standard from 1 January 2013. The competent EU bodies have completed the approval process of the standard, deferring the date of



application to 1 January 2014, allowing however early adoption beginning from 1 January 2013. The adoption by the Cairo Communication Group of this standard had no impact on the data in the Annual Financial Report.

- **IFRS 12 – Disclosure of interests in other entities** – The standard, issued by the IASB in May 2011, establishes the disclosure of additional information to provide on all types of interests, including those in subsidiaries, joint arrangements, associates, special purpose entities and other unconsolidated structured entities. The IASB requires retrospective application of the standard from 1 January 2013. The competent EU bodies have completed the approval process of the standard, deferring the date of application to 1 January 2014, allowing however early adoption beginning from 1 January 2013. The effects of the adoption of the new standard are limited to disclosure relating to interests in other entities, to provide in the notes to the annual consolidated financial statements.
- **IAS 27 (2011) - Separate financial statements** – Following issue of IFRS 10 in May 2011, the IASB narrowed the scope of application of IAS 27 only to the separate financial statements. The standard specifically governs the accounting treatment of investments in the separate financial statements and is applicable from 1 January 2014. The adoption by the Cairo Communication Group of this standard had no impact on the data in the Parent’s Financial Statements.
- **IAS 28 (2011) - Investments in associates and joint ventures** - Following issue of IFRS 11 in May 2011, the IASB amended the existing standard to include in its framework investments in joint ventures, and to govern the reduction of the interest which does not result in ceasing to apply the equity method. The standard is applicable from 1 January 2014. The adoption by the Cairo Communication Group of this standard had no impact on the data in the Annual Financial Report.
- **Amendments to IAS 32 – Financial Instruments: Presentation** – The amendments issued by the IASB in December 2011 clarify the application of criteria for the offsetting of financial assets and liabilities appearing in IAS 32. The amendments must be applied retrospectively from 1 January 2014. The adoption by the Cairo Communication Group of this standard had no impact on the data in the Annual Financial Report.
- **Amendments to IFRS 10, IFRS 11 and IFRS 12 – Transition guidance amendments** – On 28 June 2012, the IASB published the amendments to IFRS applicable, together with the relevant standards, from financial periods beginning on or after 1 January 2013, unless applied earlier. The document introduces amendments to IFRS 10, 11 and 12 to clarify how an investor should adjust only the previous comparative period retrospectively and provide the information under IAS 8, paragraph 8, letter f, exempting from the provisions of the other letters of the same paragraph. IFRS 12 was further amended, in derogation of the request of adjusted comparative



information, by limiting the request of presenting comparative information for disclosures regarding unconsolidated "structured entities" in periods prior to the date of application of IFRS 12.

- ***Amendments to IFRS 10, IFRS 12 and IAS 27 – Investment entities*** – The amendment, issued by the IASB in October 2012, integrates IFRS 10 by clarifying the definition of investment entities and clarifies its consolidation methods. The amendment to IFRS 12 integrates the standard by clarifying the disclosures to provide and the assessments on how to determine investment entities. The amendment to IAS 27 integrates the standard by establishing the disclosures that the investment entity is required to provide if it is also a controlling entity. The adoption by the Cairo Communication Group of this standard had no impact on the data in the Annual Financial Report.
- ***Amendments to IAS 36 – Recoverable amount disclosures on non-financial assets*** – The standard, issued by the IASB in May 2013, governs the disclosures to provide on the recoverable amount of impaired assets, if the amount is based on the fair value less costs of disposal. The amendments must be applied retrospectively to financial periods beginning on or after 1 January 2014. Early application is allowed for periods in which the entity has already applied IFRS 13.
- ***Amendments to IAS 39 – Novation of derivatives and continuation of hedge accounting*** – The standard, issued by the IASB in June 2013, clarifies that the amendments allow continuation of hedge accounting in the circumstance in which the derivative, which has been designated as an hedging instrument, is novated as a consequence of laws or regulations in order to replace the original counterparty to ensure performance of the obligation if certain conditions are met. The same amendment will also be included in IFRS 9 *Financial instruments*. These amendments must be applied retrospectively to financial periods beginning on or after 1^o January 2014. The adoption by the Cairo Communication Group of this standard had no impact on the data in the Annual Financial Report.
- ***IFRIC 21 – Levies*** - The interpretation, issued by the IASB in May 2013, provides guidance on when to recognize liabilities for a levy imposed by a government, with the exception of those governed by other standards (i.e. IAS 12 – *Income tax*). IAS 37 establishes the recognition criteria of liabilities, one of which is the existence of a present obligation on an entity resulting from past events (obligating event). The interpretation clarifies that the obligating event that gives rise to liability for payment of a levy is explained by the relevant legislation that gives rise to its payment. IFRIC 21 is applicable according to the IASB for financial years beginning on or after 1 January 2014, while, according to the EU Regulation, from 17 June 2014. The adoption by the Cairo Communication Group of this standard had no impact on the data in the Annual Financial Report.



Accounting standards, amendments and interpretations approved by the European Union, yet to be enforced, and not adopted in advance by the Group

- ***Amendments to IAS 19 - Employee contributions to defined-benefit plans*** - The amendment, issued by the IASB in November 2013, applies to employee contributions or to defined benefit plans. The purpose of the amendments is to simplify the accounting of contributions that are independent of the number of years of service. The amendments are effective for financial periods beginning on or after 1 July 2014; early application is allowed.
- ***Improvements to IFRS: 2010-2012 Cycle*** - On 12 December 2013, the IASB published “*Annual Improvements to IFRSs: 2010-2012 Cycle*”, which acknowledges the amendments to the standards as part of their annual improvement process. The amendments are applied to financial periods beginning on or after 1 July 2014. Early application is allowed. The main amendments regard:

IFRS 2 Share-based payments – Amendments have been made to the definitions of "vesting condition" and "market condition", while further definitions have been added of "performance condition" and "service condition" (previously included in the definition of "vesting condition").

IFRS 3 Business combinations- The amendments clarify that a contingent consideration classified as an asset or liability should be measured at fair value at each balance sheet date, regardless of whether the contingent consideration is a financial instrument to which IFRS 9 or IAS 39 applies or a non-financial asset or liability. Changes in fair value (other than period measurement adjustments) are presented in profit and loss.

IFRS 8 Operating segments - The amendments require an entity to disclose those factors used by management to identify the entity's reportable segments when operating segments have been aggregated, including a description of the aggregated operating segments and economic indicators considered in determining whether these operating segments have "similar economic characteristics". The amendments also clarify that the reconciliation between total assets of the operating segments and the total assets of the entity is provided only if the total assets of the operating segments are regularly provided to the chief operating decision-maker.

IFRS 13 Fair Value Measurement – Amendments have been made to the *Basis for Conclusions* in order to clarify that short-term receivables and payables are still able to be measured on an undiscounted basis where the effect of discounting is immaterial.

IAS 16 Property, plant and equipment and IAS 38 Intangible assets – The amendments have eliminated inconsistency in the measurement of accumulated depreciation when a tangible or intangible asset is being revalued. The new requirements clarify that the gross carrying amount



is adjusted in a manner consistent with the revaluation of the carrying amount of the asset, and that accumulated depreciation is equal to the difference between gross carrying amount and carrying amount, less subsequent depreciation.

IAS 24 Related party disclosures - It clarifies the provisions that apply in the identification of related party transactions and disclosure to provide when the activities of key management personnel are provided by a management entity (not by natural persons). In this case, the management entity is considered a related party and separate disclosure should be given on the provision of services of the management entity; as part of the disclosure on compensation to key management personnel, the components of compensation paid to the management entity need not be disclosed.

- **Improvements to IFRS: 2011-2013 Cycle** - On 12 December 2013, the IASB published “*Annual Improvements to IFRSs: 2011-2013 Cycle*”, which acknowledges the amendments to the standards as part of their annual improvement process. The amendments are applied to financial periods beginning on or after 1 July 2014. Early application is allowed. The main amendments regard:

IFRS 1 First-time Adoption of International Financial Reporting Standards – It clarifies that a first-time adopter, as an alternative to the application of a principle currently in force on the date of the first IAS/ IFRS financial statements, may opt for early application of a new standard intended to replace the principle in force. The option is admitted when the new standard allows early application. The entity is required to apply the same version of the standard in all periods presented in the first IAS/IFRS financial statements.

IFRS 3 Business combinations – The amendments aim to clarify the exclusion from the application scope of IFRS 3 of all types of joint arrangement.

IFRS 13 Fair Value Measurement – IFRS 13, paragraph 52 (*portfolio exception*), in its current version, restricts to financial assets and liabilities included in the application scope of IAS 39 the possibility of fair value measurement on a net basis. The amendment clarifies that the possibility of fair value measurement on a net basis also applies to contracts within the application scope of IAS 39 (or IFRS 9), but that do not meet the definition of financial assets and liabilities in IAS 32, such as contracts to buy and sell non-financial items that can be settled net in cash.

IAS 40 – Investment Property - The amendment clarifies that IFRS 3 and IAS 40 are not mutually exclusive and that, in order to determine whether the purchase of a property falls within the scope of IFRS 3, it is necessary to refer to the specific indications in IFRS 3; instead, to determine whether the purchase of such property falls within the scope of IAS 40, it is necessary to refer to the specific indications in IAS 40.



Accounting standards, amendments and interpretations not approved by the European Union, yet to be enforced, and not adopted in advance by the Group

- ***IFRS 14 Regulatory Deferral Accounts*** – IFRS 14, published by the IASB in January 2014, allows only first-time adopters of IFRSs to continue to recognize the amounts relating to rate regulation according to previously adopted accounting standards. In order to improve comparability with the entities that already apply the IFRSs and do not recognize these amounts, the standard requires that the effect of rate regulation should be presented separately from the other items. The principle applies from 1 January 2016; early application is allowed.
- ***Amendments to IFRS 11 Joint arrangements*** - The amendments, issued by the IASB in May 2014, provide clarification on the accounting of purchases of interests in a joint operation whose activity constitutes a business. The amendments are effective retrospectively for annual periods beginning on or after 1 January 2016; early application is allowed.
- ***Amendments to IAS 16 Property, plant and equipment and IAS 38 Intangible assets*** - The amendments, issued by the IASB in May 2014, aim to clarify that depreciation criteria determined in accordance with revenue are not appropriate, as the revenue generated by an activity that includes the use of an asset generally reflect factors other than the consumption of economic benefits of the asset. The IASB also clarified the presumption that revenue is not appropriate to measure the consumption of the economic benefits generated by an intangible asset. This presumption may, however, be overcome in limited circumstances. These amendments are effective for annual periods beginning on or after 1 January 2016; early application is allowed.
- ***IFRS 15 - Revenue from contracts with customers*** - The standard, published by the IASB in May 2014, introduces a general model to determine whether, when and to what extent will revenue be recognized. The standard replaces the recognition criteria set out in IAS 18 - *Revenue*, IAS 11 - *Work in progress* and IFRIC 13 - *Customer Loyalty Programmes*. IFRS 15 applies to financial periods beginning on or after 1 January 2017; early application is allowed.
- ***IFRS 9 – Financial instruments***. The standard, published by the IASB in July 2014, supersedes IAS 39 - *Financial Instruments: Recognition and Measurement*. IFRS 9 introduces new provisions for the classification and measurement of financial instruments, including a new model for expected losses in the calculation of impairment losses on financial assets, and new general provisions for hedge accounting. It also includes provisions for the recognition and derecognition of financial instruments in accordance with the current IAS 39. The new standard will be applicable retrospectively from 1 January 2018; early application is allowed.
- ***Amendment to IAS 27 Separate financial statements***. In August 2014, the IASB published *Equity Method in Separate Financial Statements*; the amendments to IAS 27 will allow entities



to use the equity method to account for investments in subsidiaries, joint ventures and associates in the separate financial statements. The amendments are effective for financial periods beginning on or after 1 January 2016; early application is allowed.

- ***Amendment to IFRS 10 Consolidated financial statements and IAS 28 Investments in associates and joint ventures.*** The amendment issued by the IASB in September 2014 highlights the changes to address an inconsistency in dealing with the sale or contribution of assets between an investor and its associate or joint venture. The main consequence of the changes is that a full gain or loss is recognized when a transaction involves a business. The amendments are applied to financial periods beginning on or after 1 January 2016.
- ***Improvements to IFRS: 2012-2014 Cycle.*** In September 2014, the IASB published “Annual Improvements to IFRSs: 2012-2014 Cycle”, which acknowledges the amendments to the standards as part of their annual improvement process. The amendments are applied to financial periods beginning on or after 1 January 2016. Early application is allowed. The main amendments regard:
 - IFRS 5 Non-current assets held for sale and discontinued operations* – The amendment introduces specific guidance to IFRS 5 in case an entity reclassifies an asset (or disposal group) from held for sale to held-for-distribution (or vice versa), or when recognition of an asset held-for-distribution ceases.
 - IAS 19 Employee benefits* - The amendment to IAS 19 clarifies that high quality corporate bonds used to determine the discount rate of post-employment benefits must be issued in the same currency used in the payment of the benefits.
 - IAS 34 Interim financial reporting* - The document clarifies the requirements in the event that the disclosures required are presented in the interim financial report but not in the interim financial statements. The amendment requires that the disclosures be incorporated by cross-reference between the interim financial statements and wherever they are included within the interim financial report and that the document be available to users of the financial statements on the same terms as the interim financial statements and at the same time.
 - IFRS 7 Financial instruments: disclosures*- The document introduces additional guidance to clarify whether a servicing contract constitutes a continuing involvement in a transferred asset for the purposes of applying these disclosure requirements to the transferred assets.
- ***Amendment to IAS 1.*** In December 2014, the IASB published “Disclosure Initiative” The main amendments regard: *Materiality and aggregation*: An entity must not reduce the understandability of its financial statements by obscuring useful information with irrelevant information or by aggregating relevant information that has different characteristics or functions. Additional subtotals must be reconciled to the subtotal and totals required.



Information to be presented in the statement of financial position and of comprehensive income: specific items of profit or loss, other comprehensive income and the statement of financial position can be disaggregated. Subtotals must: be made up of items recognized and measured in accordance with IFRS, be presented and labeled in order to make the components of the subtotal clear and understandable; be consistent from period to period. Statement of other comprehensive income for the year: the share of other comprehensive income of associates and joint ventures accounted for using the equity method must be presented in aggregate form but separately from other comprehensive income, as a single item, based on whether the items will or will not subsequently be reclassified to profit or loss. Notes – Structure: the entity is free to decide the order of presentation in the financial statements, but must consider the effect on the understandability and comparability of its financial statements, emphasizing the most relevant operating segments for the understanding of its financial performance and financial position.

The amendments are applied to financial periods beginning on or after 1 January 2016. Early application is allowed.

- ***Amendment to IFRS 10, IFRS 12 and IAS 28 - Investment entities: consolidation exceptions*** - In December 2014, the IASB published "Investment Entities: Applying the Consolidation Exception". The main amendments regard:

IFRS 10 Consolidated financial statements – The amendments to the IFRS clarify that the exemption from presenting consolidated financial statements applies to a parent entity that is a subsidiary of an investment entity, when the investment entity measures all of its subsidiaries at fair value.

IAS 28 Investments in Associates - The amendment to IAS 28 allows a non-investment entity, when applying the equity method of accounting for its investment in an associate or a joint venture that is an investment entity, to retain the fair value measurement that is applied by that associate or joint venture to its subsidiaries.

IAS 12 Disclosure of interests in other entities - The amendment clarifies that this principle does not apply to an investment entity that prepares the financial statements in which all of its associates are measured at fair value through profit and loss.

The amendments are applied retrospectively to financial periods beginning on or after 1 January 2016. Early application is allowed.



NOTES TO THE INCOME STATEMENT

1. Revenue

Net operating revenue amounted to Euro 116,595 thousand (Euro 121,047 thousand in 2013). Its composition, versus 2013, is shown below:

Revenue (€ thousands)	31/12/14	31/12/13
Print media advertising space sales	32	43
Cairo Pubblicità TV sub-concession	111,592	116,228
Cairo Pubblicità print media sub-concession	716	877
Cairo Pubblicità Web sub-concession	653	297
Group services	3,502	3,502
Other revenue from associates	100	100
Total	116,595	121,047

Revenue is generated exclusively in Italy and an analysis by geographical area is pointless.

In 2014, Cairo Communication continued to operate on the TV advertising sales market (La7, La7d and theme channels Cartoon Network, Boomerang, and CNN) and on the Internet through its subsidiary Cairo Pubblicità, which operates on a sub-concession basis, invoicing advertising spaces directly to its clients and returning to the sub-grantor Cairo Communication a share of revenue generated by resources managed on a sub-concession basis.

In 2014, net operating revenue included the sub-concession fees billed to the subsidiary Cairo Pubblicità S.p.A. for:

- TV advertising sales, amounting to Euro 111,592 thousand,
- Internet advertising sales, amounting to Euro 653 thousand.
- print media advertising sales on “Prima Comunicazione” and “Uomini e comunicazione” of Editoriale Genesis S.r.l., amounting to Euro 716 thousand.

Apart from providing advertising services, Cairo Communication also provides services in administration, auditing, financial analysis, debt management and collection and marketing, to other Group companies. Such services are subject to contracts which are revised annually. Sales to Group companies deriving from these activities during the year were as follows:



Group services (€ thousands)	31/12/14	31/12/13
Cairo Pubblicità S.p.A.	3,000	3,000
Il Trovatore S.r.l.	22	22
Cairo Editore S.p.A.	480	480
Total	3,502	3,502

Other revenue from associates (Euro 100 thousand) relates to administrative services provided to Torino FC S.p.A., a related party in that it is ultimately controlled by U.T. Communications S.p.A.

2. Other revenue and income

Other revenue and income amounted to Euro 350 thousand (Euro 1,217 thousand in 2013).

3. Services, use of third-party assets and other operating costs

Net operating revenue amounted to Euro 107,831 thousand (Euro 111,617 thousand in 2013). Its composition, versus 2013, is shown below:

Cost of services (€ thousands)	31/12/14	31/12/13
Publishers' fees	770	915
TV publishing fees	103,300	107,139
Web publishing fees	581	254
Consultancies and collaborations	306	33
Cairo Communication Board of Directors' fees	1,257	1,605
Cairo Communication Board of Statutory Auditors' fees	71	75
Other administration and general expenses	1,546	1,596
Total	107,831	111,617

The decrease in "TV publishers' fees" is ascribable to the decrease in TV advertising revenue.

Use of third-party assets amounted to Euro 715 thousand (Euro 677 thousand in 2013) and refers mainly to lease payments for property and office equipment.

Other operating costs amounted to Euro 91 thousand (Euro 181 thousand in 2013) and refer to prior-year expense of Euro 31 thousand and other costs of Euro 60 thousand.



4. Personnel expense

This item can be analyzed as follows:

Personnel expense (€ thousands)	31/12/14	31/12/13
Wages and salaries	2,117	2,005
Social security charges	795	745
Other expense	-	20
Post-employment benefits	78	74
Total	2,990	2,844

5. Amortization, depreciation, provisions and impairment losses

These can be analyzed as follows:

Amortization, depreciation, provisions and impairment losses (€ thousands)	31/12/14	31/12/13
Amortization of intangible assets	92	60
Depreciation of property, plant and equipment	148	136
Additions to provisions for risks	50	76
Total	290	272

6. Net financial income

Net financial income amounted to Euro 365 thousand (Euro 1,016 thousand in 2013) and is broken down as follows:

Net financial income (€ thousands)	31/12/14	31/12/13
Interest income on bank accounts	505	1,137
Interest income from Cairo Publishing	1	1
Total financial income	506	1,138
Interest and other financial expense	(141)	(122)
Total financial expense	(141)	(122)
Net financial income	365	1,016



7. Income/ (loss) on investments

This item includes:

- dividends received during the year from the subsidiaries Cairo Pubblicità and Cairo Editore, amounting respectively to Euro 1,039 thousand and Euro 6,245 thousand (Euro 3.4 million and Euro 9.7 million in 2013);
- adjustment of the investment held in Cairo Publishing S.r.l., amounting to Euro 200 thousand.

In 2013, the item included the dividends approved by Cairo Pubblicità, amounting to Euro 3.4 million, and by Cairo Editore, amounting to Euro 9.7 million, the gain from the sale of Dmail Group shares, amounting to Euro 377 thousand, as well as the adjustment of the investment held in Cairo Publishing S.r.l., amounting to a negative Euro 0.3 million.

.*.:

8. Income tax

Income tax for the year amounted to Euro 1,891 thousand (Euro 2,797 thousand in 2013). In accordance with the relevant accounting standards, the deferred tax assets, relating mainly to the accrual of provisions whose fiscal deductibility is deferred, were recognized.

Tax (€ thousands)	31/12/14	31/12/13
Current tax		
Ires	1,507	2,233
Irap	326	410
Deferred tax assets	107	20
Deferred tax liabilities	(49)	134
Total	1,891	2,797

The reconciliation of the effective and theoretical tax charge can be analyzed as follows:

	31/12/14	31/12/13
Pre-tax profit	12,477	20,863
Theoretical income tax charge (27.5%)	3,431	5,737
Tax effects of dividends received	(1,903)	(3,437)
Tax effects of other permanent differences	37	87
Irap	326	410
Current and deferred income tax for the year	1,891	2,797



For a clearer understanding of the reconciliation of effective and theoretical tax charge, IRAP has not been taken into account as this is not based on pre-tax profit, and this would generate a distorting effect between one year and the other. Therefore, the theoretical income tax charge has been calculated using the IRES rate in force at 31 December 2014, equal to 27.5%.

..*

9. Loss from discontinued operations

At 31 December 2014, this included the allocation of Euro 1 thousand for the loss of the year incurred by the subsidiary Diellesei S.r.l. in liquidation. At 31 December 2013, the item amounted to Euro 5 thousand.

NOTES TO THE STATEMENT OF FINANCIAL POSITION

10. Property, plant and equipment

At 31 December 2014, this item amounted to Euro 457 thousand, with a net decrease of Euro 91 thousand versus 31 December 2013. Movements can be broken down as follows:

Description	Historical cost	Revaluation	Accumulated depreciation	Carrying amount 31/12/2013	Net change	Carrying amount 31/12/2014
Motor vehicles	472	0	(394)	78	(31)	47
Furniture and fittings	391	0	(223)	168	(18)	150
Communication equipment	77	0	(72)	5	(2)	3
Electronic office equipment	1,262	0	(1,017)	245	(30)	215
Plant (various)	124	0	(124)	-	-	-
Mobile phones	28	0	(21)	7	5	12
Leasehold improvements	271	0	(226)	45	(15)	30
Total other assets	2,625	0	(2,077)	548	(91)	457

The net change in the year is broken down as follows:



Description	Additions	Change in accumulated depreciation from disposals	Depreciation	Net change
Motor vehicles	-	-	(31)	(31)
Furniture and fittings	-	-	(18)	(18)
Communication equipment	-	-	(2)	(2)
Electronic office equipment	43	-	(73)	(30)
Plant (various)	-	-	-	-
Mobile phones	8	-	(3)	5
Leasehold improvements	7	-	(22)	(15)
Grand total	58	-	(148)	(91)

Property, plant and equipment have not been subject to revaluation.

The item also includes leasehold improvements depreciated over the term of the lease.

.*.*. .

11. Intangible assets

Intangible assets amounted to Euro 320 thousand at 31 December 2014, decreasing by Euro 37 thousand versus 31 December 2013. Their movements during the year are as follows:

Description (€ thousands)	Historical cost	Accumulated depreciation	Carrying amount at 31/12/2013	Net change	Carrying amount at 31/12/2014
Software, licenses and trademarks	2,530	(2,398)	132	141	273
Total concessions, licenses and trademarks	2,530	(2,398)	132	141	273
Website design costs	169	(169)	-	-	-
Assets under development	225	-	225	(178)	47
Total other	394	(169)	225	-	-
Total intangible assets	2,924	(2,567)	357	(37)	320

The net change in the year is broken down as follows:

Description (€ thousands)	Additions	Reclassification s	Amortization	Net change
Software	26	207	(92)	141
Total concessions, licenses and trademarks	26	207	(92)	141
Assets under development	29	(207)	-	(178)
Total intangible assets	55	-	(92)	(37)



Expenses incurred for procedures and software programs are amortized over 3 and 5 financial years.

.*. *.

12. Investments

Investments in subsidiaries

At 31 December 2014, investments amounted to Euro 23,124 thousand, with a net change of Euro 5,510 thousand versus 31 December 2013.

Description (€ thousands)	Carrying amount at 31/12/2013	Impairment losses	Value increases (decreases)	Carrying amount at 31/12/2014
Diellesei S.r.l. in liquidation	0	-	-	0
Cairo Network S.r.l. (former Cairo Sport S.r.l.)	10	(1)	5,511	5,520
La7 S.r.l.	4,039	-	-	4,039
Il Trovatore S.r.l.	357	-	-	357
Cairo Editore S.p.A.	6,273	-	-	6,273
Cairo Publishing S.r.l.	1,595	(200)	200	1,595
Cairo Pubblicità S.p.A.	5,340	-	-	5,340
Total investments	17,614	(201)	5,711	23,124

During the year, Cairo Communication subscribed a share capital increase of Euro 5,511 thousand for the subsidiary Cairo Network S.r.l. (former Cairo Sport S.r.l.), which took part in 2014 in the tender procedure opened by the Ministry of Economic Development for the assignment of rights to use TV frequencies for digital terrestrial broadcasting systems, submitting its binding bid and winning the rights to use a lot of frequencies ("Mux") for a period of 20 years.

Furthermore, Cairo Network was granted interest-free loans for a total of Euro 1,650 thousand.

Moreover, in 2014:

- the liquidation of the subsidiary Diellesei continued, generating a loss of Euro 1 thousand. The net deficit of the company is covered by the provision for investment risks at 31 December 2014,
- Cairo Communication waived, in the reserve for losses accrued or to be accrued, interest-bearing loans of Euro 200 thousand provided to the subsidiary Cairo Publishing S.r.l..

Annex 2 shows the information required by paragraph V of art. 2427 of the Italian Civil Code. Information at 31 December 2014 is drawn from the draft financial statements approved by the Board of Directors of each direct and/or indirect subsidiary.



For more detailed information, a comparison between carrying amount and the amount derived from the application of the equity method is provided for each investment in the following table.

Description (€ thousands)	Equity 31/12/2014 (*)	Ownership %	Equity method (*) (a)	Carrying amount (b)	Difference (a-b)
Cairo Editore S.p.A.	9,534	99.95%	21,940	6,273	15,667
La 7 S.r.l.	112,658	100%	76,776	4,039	72,737
Il Trovatore S.r.l.	183	80%	310	357	(47)
Cairo Pubblicità S.p.A.	3,110	100%	5,374	5,340	34
Diellesei S.r.l. in liquidation	(128)	60%	(128)	(128)	0
Cairo Publishing S.r.l.	52	100%	51	1,595	(1,554)
Cairo Network S.r.l. (former Cairo Sport S.r.l.)	5,513	100%	5,514	5,520	(6)

(*) Amounts determined under IAS/IFRS

The carrying amount of the investments in Il Trovatore S.r.l. and Cairo Publishing S.r.l. is higher than the amount obtained using the equity method, respectively by Euro 47 thousand and Euro 1,554 thousand.

The carrying amounts of investments have undergone impairment tests to measure any potential indication of impairment of their realizable values, as defined by value in use, that is, the present value of their cash flow, estimated according to the expected results of the investments based on the most recent budgets and business plans. The use of these estimates is believed to support the carrying amount of the investment.

The main assumptions for the calculation of value in use are as follows:

- three-year budget period,
- a growth rate of 1% to extrapolate the cash flows beyond the current budget period,
- a weighted average cost of capital (*wacc*) of 10.5% considered consistent with the company's industry.

The company prepares Group consolidated financial statements which, taking account of the investments held, are an essential document to ensure complete understanding of the activities of the Group, the Parent and its investments.

.*.*



13. Receivables from subsidiaries and other non-current financial assets

Other non-current financial assets

At 31 December 2014, non-current financial assets amounted to Euro 1.663 thousand (Euro 13 thousand at 31 December 2013), relating to interest-free loans granted to the subsidiary Cairo Network S.r.l. (Euro 1,650 thousand) and to security deposits (Euro 13 thousand).

..*

14. Deferred tax assets

At 31 December 2014, deferred tax assets amounted to Euro 424 thousand (Euro 493 thousand at 31 December 2013). These assets can be analyzed as follows:

	31/12/14		31/12/13	
	Temporary differences	Tax effect	Temporary differences	Tax effect
Deferred tax assets (€ thousands)				
Taxed allowance for impairment	719	199	761	209
Other temporary differences	564	157	917	258
Post-employment benefits IAS	247	68	96	26
Total deferred tax assets	1,530	424	1,774	493

Deferred tax assets relate to the recognition at 31 December 2014 of deferred tax assets on the temporary differences between the carrying amount of recognized assets and liabilities and their tax values.

Deferred tax assets are recognized to the extent they are considered recoverable depending on the presence of future taxable income in which temporary differences will be reversed. Management periodically reviews the estimates underlying the recoverability of these amounts.

15. Trade receivables

Trade receivables amounted to Euro 320 thousand, decreasing by Euro 215 thousand versus 31 December 2013. These are broken down as follows:



Trade receivables (€ thousands)	31/12/14	31/12/13	Change
Trade receivables	990	1,247	(257)
Allowance for impairment	(670)	(712)	42
Total trade receivables	320	535	(215)

Since 2009, Cairo Communication has operated on the advertising sales market on a sub-concession basis with the subsidiary Cairo Pubblicità, which invoices directly to its customers and returns a share of the revenue to its parent. Current receivables arising from this activity accrue from the subsidiary.

The ageing of trade receivables by due date is as follows:

31 December 2014 (€ thousands)	Current	Past due between 30 and 60 days	Past due between 61 and 90 days	Past due between 91 and 180 days	Past due over 180 days	Total
Trade receivables	145	-	-	30	815	990
Allowance for impairment	-	-	-	-	(670)	(670)
Trade receivables	145	-	-	30	145	320

31 December 2013 (€ thousands)	Current	Past due between 30 and 60 days	Past due between 61 and 90 days	Past due between 91 and 180 days	Past due over 180 days	Total
Trade receivables	266	-	-	30	951	1,247
Allowance for impairment	-	-	-	-	(712)	(712)
Trade receivables	266	-	-	30	239	535

Trade receivables are shown net of allowance for impairment that has been determined taking account specific collection risks and takes into account the allocation to the Company's media clients of a percentage of losses on receivables, equal to the percentage of sales revenue allocated, pursuant to advertising space sales contracts signed between the two parties. Specifically, receivables due more than 180 days are those which arose when the Company used to operate directly as an advertising agency. Since 2009, advertising sales have been managed under a sub-concession agreement with the subsidiary Cairo Pubblicità.



16. Receivables from subsidiaries

These amounted to Euro 65,475 thousand, decreasing by Euro 10,940 thousand versus 31 December 2013. These are broken down as follows:

Receivables from subsidiaries (€ thousands)	31/12/14	31/12/13	Change
La7 S.r.l (former Cairo Due S.r.l.)	1,718	-	1,718
Cairo Editore S.p.A.	6,689	10,224	(3,535)
Il Trovatore S.r.l.	390	364	26
Cairo Publishing S.r.l.	199	90	109
Cairo Pubblicità S.p.A.	56,479	65,737	(9,258)
Total receivables from subsidiaries	65,475	76,415	(10,940)

Receivables from La7 S.r.l. - Euro 1,654 thousand - are mainly receivables from VAT transferred to the parent as a result of the VAT grouping scheme.

Receivables from Cairo Editore include Euro 6,246 thousand for dividends to receive as resolved by the Shareholders' Meeting of the subsidiary in December 2014.

Receivables from Cairo Pubblicità S.p.A. - Euro 55,056 thousand at 31 December 2014 - are mainly receivables from the sub-concession contracts, and Euro 174 thousand from VAT transferred to the parent as a result of the VAT grouping scheme.

Other trade receivables from Cairo Pubblicità S.p.A., as those from Il Trovatore S.r.l., are mainly referable to centralized services provided by Cairo Communication S.p.A. to Group companies. These services are provided through annual contracts at market values renewable year by year.

.*.*

17. Other receivables and other current assets

These amounted to Euro 1,148 thousand, increasing by Euro 93 thousand versus 31 December 2013, and can be analyzed as follows:



Other receivables and other current assets (€ thousands)	31/12/14	31/12/13	Change
VAT credit	-	119	(119)
Prepaid IRAP	75	67	8
Receivables from others	508	522	(14)
Prepayments and accrued income	565	347	218
Total other receivables and other current assets	1,148	1,055	93

Withholding and prepaid taxes are taken as a deduction from the payment of taxes to relevant authorities.

18. Cash and cash equivalents

The item coincides with the **net financial position** and amounted to Euro 25,768 thousand, decreasing by Euro 9,922 thousand versus 2013. It can be analyzed as follows:

Cash and cash equivalents (€ thousands)	31/12/14	31/12/13	Change
Bank and post office deposits	25,766	35,680	(9,914)
Cash and valuables on hand	2	10	(8)
Total	25,768	35,690	(9,922)

Cash and cash equivalents continued to be managed prudently.

.*. *.

19. Equity

At 31 December 2014, equity amounted to Euro 57,173 thousand, decreasing by Euro 10,664 thousand versus 31 December 2013, mainly as a result of the distribution of the 2013 dividend resolved by the Shareholders' Meeting of 29 April 2014 (Euro 21,152 thousand), and of the overall result of 2014 (Euro 10,488 thousand).

At their Meeting on 29 April 2014, the shareholders approved the distribution of a dividend of 0.27 Euro per share, inclusive of tax, with coupon detachment date on 12 May 2014 (made payable on 15 May 2014), for a total of Euro 21.2 million.



Share capital

The share capital at 31 December 2014 was Euro 4,074 thousand, subscribed and fully paid up, comprising n. 78,343,400 ordinary shares to which no nominal amount is attributed.

In accordance with the bylaws, the shares are registered, indivisible and freely transferable. The requirements of representation, legitimization, circulation of the company investment required for securities traded on regulated markets continue to apply.

Each share has the right to a proportion of the profit which has been approved for distribution and to a portion of equity on liquidation and also has the right to vote, without limits other than those as defined by the Law.

No securities carrying special controlling rights have been issued.

No financial instruments have been issued attributing the right to subscribe to newly-issued shares.

No share incentive plans are envisaged involving share capital increases, including bonus issues.

The reconciliation between the number of shares outstanding at 31 December 2014 and those at 31 December 2013 is as follows:

	31/12/2013	Purchase of treasury shares	Disposal of treasury shares	31/12/2014
Ordinary shares issued	78,343,400	-	-	78,343,400
Less: Treasury shares	(779)	-	-	(779)
Ordinary shares outstanding	78,342,621	-	-	78,342,621

Share premium reserve

At 31 December 2014, the share premium reserve amounted to Euro 41,062 thousand.

Retained earnings

At 31 December 2014, the balance showed a positive Euro 397 thousand. The item includes the IAS first-time adoption reserve, with a negative balance of Euro 1,313 thousand.

Retained earnings (€ thousands)	31/12/2014	31/12/2013
Retained earnings	1,710	1,807
Retained earnings – “first-time adoption” reserve	(1,313)	(1,313)
Total	397	494



Other reserves

At 31 December 2014, the item amounted to Euro 1,057 thousand, unchanged versus 2013. It can be analyzed as follows:

Other reserves	31/12/2014	31/12/2013
(€ thousands)		
Legal reserve	815	815
Negative goodwill	225	225
Other reserves	17	17
Total	1,057	1,057

Treasury shares reserve

In 2014, as part of the share buy-back plans, no treasury shares were sold or purchased. At 31 December 2014, Cairo Communication held a total of n. 779 treasury shares, or 0.001% of the share capital, subject to art. 2357-ter of the Italian Civil Code.

At their meeting on 29 April 2014, after revoking a similar resolution adopted on 29 April 2013, the Shareholders approved the proposal to acquire and dispose of treasury shares in accordance with art. 2357 and subsequent articles of the Italian Civil Code, for the purpose of stabilizing the Company share price and sustaining liquidity, and, if deemed necessary by the Board of Directors, through an independent intermediary, of establishing a “shares stock” as provided in Consob regulation 16839/2009. The Board was authorized to acquire treasury shares up to the maximum number permitted by law, for a period of 18 months from the date of authorization, by use of available reserves, including the share premium reserve, as resulting from the last approved annual financial statements. Specifically, the Board of Directors will be authorized to acquire treasury shares on one or more occasions, acquiring shares directly on the market and through authorized intermediary – in accordance with the procedures provided by art. 144 bis, paragraph 1, letter b of the Issuer Regulation and relevant Instructions – and, in case such operations are carried out, according to accepted market practices, pursuant to the regulations introduced by Consob Resolution No. 16839/2009. Minimum price and maximum acquisition price per share are set at an amount equal to the average official purchase price of the share on Borsa Italiana S.p.A. for the 15 working days preceding the purchase, respectively reduced or increased by 20%. In case such operations are carried out according to accepted market practices under Consob Resolution 16839/2009, the purchase of treasury shares shall be subject to further limits, including price limits, provided therein. The Board was authorized to sell, on one or more occasions, any acquired treasury shares, setting the minimum sale price per share no lower than the minimum price calculated following the criteria adopted for their purchase. Should the treasury shares be sold according to accepted market



practices under Consob Resolution 16839/2009, the sale of treasury shares shall be subject to further limits, including price limits, provided therein.

.*. *.

The following table shows equity items and indicates if they can be used and distributed, and tax restrictions if any:

Amount/Description	Amount	Eligibility for use:	Available portion	Use over the previous three years	
				To cover losses	Other (dividends)
Share capital	4,074	---	---	---	---
Treasury shares	(2)	---	---	---	---
Share premium reserve	41,062	ABC	41,062 (1)	---	(5,628)
Legal reserve	815	B	---	---	---
Other reserves	17	ABC	17	---	---
Negative goodwill	225	ABC	225	---	---
Retained earnings	396	ABC	396	---	(58,188)
Total	46,587		41,700		(63,816)

Legend:

A - for increases in share capital

B - to cover losses

C - dividend

(1) In accordance with art. 2431 of the Italian Civil Code, the entire amount of this reserve may be distributed provided the legal reserve has reached the limit as defined by art. 2430 of the Code

Profit for the year

Profit for the year amounted to Euro 10,586 thousand (Euro 18,061 thousand at 31 December 2013).

20. Post-employment benefits

This item amounted to Euro 1,221 thousand, with an increase by Euro 213 thousand versus 2013.

The movement is analyzed below:

	Balance at 31/12/2013	Paid during the year	Financial expense	Accrued during the year	Actuarial adjustment	Balance at 31/12/2014
Post-employment benefits	1,008	-	35	78	100	1,221
Total	1,008	-	35	78	100	1,221

The change in the composition of personnel during the year is summarized as follows:



	Headcount at the beginning of the year	Changes	Headcount at year-end	Average headcount
Senior managers	7	-	7	7
Managers	3	-	3	3
Employees	18	-	18	18
Total	28	-	28	28

.*.*

21. Provisions for risks and charges

Provisions for risks and charges amounted to Euro 264 thousand, decreasing by Euro 73 thousand versus 2013.

Provisions for risks and charges	Balance at 31/12/2013	Utilizations	Released	Accrued	Balance at 31/12/2014
(€ thousands)					
Risks on investments	128	-	-	-	128
Other risks	75	(75)	-	50	50
Deferred tax provision	134	(134)	-	86	86
Grand total	337	(209)	-	136	264

As mentioned earlier, the “provision for risks on investments” refers entirely to Diellesei S.r.l. in liquidation, accrued during 2005/2006 as a result of the subsidiary’s net deficit.

.*.*

22. Trade payables

Trade payables amounted to Euro 2,147 thousand, decreasing by Euro 1,457 thousand versus 31 December 2013.

23. Receivables from and payables to parent

Receivables from parents amounted to Euro 796 thousand, increasing by Euro 148 thousand versus 31 December 2013. Euro 735 thousand refers to receivables from U.T. Communications arising from the national tax consolidation scheme. The receivables stem from the tax advance payments netted against tax liabilities for the year.

As mentioned earlier, Cairo Communication and its subsidiaries Cairo Editore S.p.A., Cairo Pubblicità S.p.A., Diellesei S.r.l. in liquidation, La 7 S.r.l., Cairo Network S.r.l. (former Cairo Sport S.r.l.) and Cairo Publishing S.r.l. participate in the national tax consolidation scheme of U.T. Communications S.p.A.

The consolidation scheme, which governs the financial aspects of amounts paid or received in return for the advantages or disadvantages resulting from the tax consolidation, specifically provides that



any greater charges or minor benefits that may accrue to the company resulting from participation in the procedure, be suitably remunerated by the Parent.

24. Payables to subsidiaries

Payables to subsidiaries amounted to Euro 55,516 thousand, decreasing by Euro 2,737 thousand versus 31 December 2013. The following table shows the breakdown of payables to subsidiaries that relate to services received in the ordinary course of business:

Payables to subsidiaries	31/12/14	31/12/13	Change
(€ thousands)			
La7 S.r.l.	52,590	55,570	(2,980)
Cairo Pubblicità S.p.A.	2,854	2,556	298
Cairo Publishing S.r.l.	6	6	-
Il Trovatore S.r.l.	66	121	(55)
Total payables to subsidiaries	55,516	58,253	(2,737)

25. Tax liabilities

Payables to subsidiaries amounted to Euro 1,291 thousand, increasing by Euro 1,064 thousand versus 31 December 2013. They are broken down as follows

Tax liabilities	31/12/14	31/12/13	Change
(€ thousands)			
Withholding taxes on employees	177	207	(30)
Withholding taxes on contract workers	77	20	57
VAT payable	1,037	-	1,037
Total tax liabilities	1,291	227	1,064

As mentioned earlier, the taxable income of Cairo Communication S.p.A., for IRES purposes, has been recognized as a payable to the parent UT Communications S.p.A., in accordance with the national tax consolidation scheme.



26. Other current liabilities

Other current liabilities amounted to Euro 1,884 thousand, decreasing by Euro 220 thousand versus 31 December 2013. They are broken down as follows

Other current liabilities	31/12/2014	31/12/2013	Change
(€ thousands)			
Social security charges payable	215	203	12
Other liabilities	1,669	1,841	(172)
Deferred income	-	60	(60)
Total other current liabilities	1,884	2,104	(220)

Accrued expenses and deferred income are determined on an accruals basis and mainly relate to income deriving from recharging of the share of print media bad debts, the losses of which have not been fully ascertained and have not been recognized in profit and loss

27. Commitments, risks and other information

Guarantees and commitments

Main guarantees given and/or received are as follows:

- Cairo Communication issued Unicredit S.p.A. a guarantee to secure the bank loan of Euro 25 million granted in July 2014 to the subsidiary Cairo Network for the purchase of the rights to use television frequencies, as explained in the Directors' report; the loan agreement contains certain financial covenants, to be verified annually at Group level (consolidated financial statements): the debt cover (the net debt/EBITDA ratio) must be less than or equal to 1.75 and the leverage (the net debt/equity ratio) less than or equal to 1; breach of the commitment and/or financial covenants may result in termination of the loan agreement, pursuant to Article 1456 of the Italian Civil Code. Early repayment is provided for in the event of a change of control of Cairo Network S.r.l.;
- bank guarantee issued by Unicredit of Euro 17.6 million, expiring on 15 June 2015, securing payment of minimum guaranteed fees, under the contract for the exclusive sale of television advertising space on La7;
- other guarantees issued by bank and insurance institutes to customers, public bodies and lessors of property totaling Euro 2.397 thousand.



The agreements reached in the purchase of the entire share capital of La7 S.r.l. also included a multi-year agreement between La7 and Telecom Italia Media Broadcasting S.r.l. (TIMB) for the supply of transmission capacity that provides, among other things, the issue by Cairo Communication of a parent company guarantee to cover the payment obligations undertaken by La7, for a maximum amount of Euro 6,558 thousand (including VAT) per year.

The contract, signed on 6 March 2013 with Telecom Italia Media for the acquisition of the entire share capital of La7 S.r.l., also provides for:

- the buyer's commitment, for a period of 24 months (lock-up) from the date of finalization of the acquisition (30 April 2013), not to sell, assign, transfer, dispose of in any way, in whole or in part, the investment in La7, or the business unit owning La7, without prejudice to the buyer's right, including during lock-up, to:
 - o undertake a transfer or assignment to entities wholly-owned, whether directly or through other companies wholly-owned by Cairo Communication;
 - o merge La7 and Cairo Due S.r.l., provided the latter, at the effective date of the merger, does not have a negative net financial position in excess of Euro 1,020 thousand;
 - o constitute real rights of guarantee in favor of the lending banks on the shares of LA7;
 - o undertake, under certain conditions, a proportional demerger of the group.

The lock-up commitments are accompanied by a penalty clause of the amount of Euro 20 million.

- Cairo Communication's commitment, for a period of 24 months from the date of finalization of the acquisition, to use the financial resources arising from the contribution received from Telecom Italia Media in the exclusive interest and for the restructuring of La7, and the related prohibition to engage in certain transactions specified in the contract, including of an extraordinary kind, aimed at depriving La7 of the resources from the contribution to the benefit of third parties or related parties, or to make new investments.

This commitment, as the above, is accompanied by a penalty clause, the amount of which varies depending on the transaction.

In 2014, the subsidiary Cairo Network S.r.l. (former Cairo Sport S.r.l.) took part in the tender procedure opened by the Ministry of Economic Development for the assignment of rights to use TV frequencies for digital terrestrial broadcasting systems, submitting its binding bid and winning the rights to use a lot of frequencies ("Mux") for a period of 20 years. In January 2015, Cairo Network and EI Towers S.p.A. ("EIT") therefore entered into the agreements for the realization and subsequent long-term technical management in full service mode (hospitality, service and



maintenance, use of broadcasting infrastructure, etc.) of the Mux. The agreements provide, among other things, for:

- a transitional phase, which will see the realization and start-up of the MUX and the initial operations, which will run from the date the agreements were signed to 31 December 2017, and an operational phase of the Mux lasting 17 years (from 2018 to 2034);
- the right to free withdrawal of Cairo Network starting from 1 January 2025;
- guaranteed coverage at full performance of at least 94% of the population, in line with national Muxs with greater coverage;
- consideration to EIT:
 - o during the transitional phase (2015-2017), amounting to a total of Euro 11.5 million for the full three-year period;
 - o at full performance (starting from 2018), amounting to Euro 16.3 million per year.

These amounts include compensation for the availability of the transmitters;

- an annual consideration from EIT to Cairo Network, starting from 2018, ranging between Euro 0 up to Euro 4 million, in the event that the available bandwidth on the Mux is not fully used by Cairo Network.

With the acquisition and realization of the Mux, the Cairo Communication Group will start operations as a network operator.

With regard to the Automatic Numbering Plan, the numbers currently in use (7 for La7 and 29 for La7d) are those assigned by the Ministry of Economic Development in 2010, under AGCOM resolution 366/2010/CONS. The Resolution had been challenged by Telenorba and other local broadcasters, with partial annulment specifically regarding the assignment of numbers 7-8 and 9 by the Council of State through Ruling 4660/12.

On 21 March 2013, the Communications Authority (AGCOM) unanimously approved the New Automatic Numbering Plan for digital terrestrial television (LCN) by Decision 237/13/CONS. The decision confirmed, for national traditional broadcasters, the assignment of numbers 0-9 of the first block of LCN numbering (see p. 39-40 and 44 of AGCOM Decision no. 237/13/CONS).

Deeming that the New Plan evaded the Council of State's ruling (seeing that it confirmed assignment to the national traditional broadcasters of numbers 0-9 in the first block of LCN numbering), Telenorba filed an appeal for compliance with ruling n. 4660/12. The appeal was upheld by the Council of State (ruling no. 6021 of 16 December 2013), which declared the New Numbering Plan void (pursuant to Resolution 237/2013) for numbers from 8 to 9, and appointed a special commissioner tasked with verifying the correct assignment of numbers from 8 to 9 within 90 days from the beginning of the proceedings, which started on 24 February 2014. However, since the partial annulment of the previous Plan initially included number 7, on initiation of the procedure, the special



commissioner - inappropriately in the opinion of La7 - also referred to number 7, which instead, under the Ruling, is not subject to verification by the Commissioner. AGCOM has in the meantime re-extended the previous Plan (based on current assignments), as also suggested in the State Council's ruling, in order to avoid a regulatory void.

In execution of ruling no. 6021, the Special Commissioner launched a public consultation on an outline provision named "Automatic numbering plan of digital terrestrial free-to-air and pay TV channels, procedures for allocating numbers to providers of audiovisual services authorized to broadcast audiovisual content using digital terrestrial technology and relating conditions of use." Telenorba, All Music and AGCOM have challenged the acts adopted by the Commissioner, lodging enforcement reviews and claims before the State Council (the court of compliance), arguing that the Commissioner had exceeded the requirements of sentence no. 6021 of 2013.

Following orders n. 5041, 5127 and 5859 of 2014, under which the Council of State has given the Commissioner certain regulations to discharge the task, the Commissioner adopted a new outline provision (no. 7 of 2014), accompanied by an explanatory report.

The parties to the proceedings and the Commissioner were heard in personal hearings before the President of the Panel and the Judge-Rapporteur on the assessments made by the Commissioner in the acts recently adopted.

The Commissioner has yet to complete his task (expiry is currently set on 20 May 2015), while the Council of State has yet to rule on the enforcement reviews and claims lodged by Telenorba, All Music and AGCOM.

In the opinion of La7 and its legal counsels, in light of the task discharged by the Commissioner and the orders of the State Council, further assessments by the State Council on number 7 are unlikely to be made, nor will the allocation of this number to La7 be challenged.

As the result of a VAT audit performed on Cairo Communication S.p.A., in its report, the Guardia di Finanza (the Italian Tax Police) identified some findings for 2002 and subsequent years (2003, 2004, 2005 and 2006) relating to the application of VAT on dealing rights charged to media centres, which were subsequently included in the final audit reports issued in January 2008 (for 2002), in June 2008 (for 2003, 2004 and 2005) and on 24 November 2011 (for 2006), which the company has challenged. The relevant hearing was held on 23 May 2014 and, to date, its judgment has yet to be filed. For all the periods in question (2002, 2003, 2004 and 2005), the Provincial Tax Commission of Milan has ruled in favour of the Company's appeals. The Agenzia delle Entrate (Italian Tax Authorities) has filed an appeal with the Regional Tax Commission of Milan against these decisions. In April 2010, the Regional Tax Commission of Milan ruled in favour of the Agency's appeal regarding 2002, and in October 2011 also regarding the years 2003, 2004 and 2005, on questionable grounds. Cairo Communication has already appealed to the Court of



Cassation against the judgment regarding 2002, for which the tax claim amounts to Euro 41 thousand in addition to penalties of Euro 51 thousand, and the judgment regarding the subsequent years 2003, 2004 and 2005, for which the tax claim totals Euro 247 thousand, in addition to penalties of Euro 272 thousand and interest. The tax claim for 2006 amounts to Euro 63 thousand, in addition to penalties of Euro 79 thousand and interest. The company has also appealed against the above tax claim; the relevant hearing was held on 23 May 2014 and, to date, its judgment has yet to be filed. In June 2012, in relation to 2003, 2004, 2005 and 2006, the Company received two tax assessments demanding payment of the amounts due arising as a result of the judgment of the Regional Tax Commission, for a total claim of approximately Euro 431 thousand, including penalties and interest. In relation to the tax claim contained in these reports, based also on the advice of its tax consultants, the Directors believe there are fundamental reasons and rights to oppose the relevant findings.

In its hearing on 18 October 2010, the Provincial Tax Commission of Milan acknowledged the appeal filed by Cairo Editore S.p.A. regarding the assessment notice for tax year 2004. The Italian Tax Authorities have filed an appeal with the Regional Tax Commission of Milan against the ruling. In its hearing on 27 May 2013, the Regional Tax Commission of Milan rejected the Agency's Appeal. On 16 June 2014, the Agency filed an appeal with the Supreme Court, and on 25 July 2014, the Company notified its response to the counterparty.

A previous shareholder of the subsidiary Il Trovatore S.r.l., who did not sell its shares to the parent company, had risen a claim against the current minority shareholder, involving Cairo Communication S.p.A. indirectly, questioning the validity of the contract under which he had sold the quota in the limited partnership Il Trovatore and the transformation of this company from a limited partnership to a limited liability company (S.r.l.), and requesting the annulment of the subsequent acquisition of the company by Cairo Communication. The requests of the counterparty were rejected in the first instance, although the counterparty has filed an appeal. The case has been currently postponed to the hearing for closing arguments on 7 April 2015. Based also on the advice of its legal counsels, the Directors believe that the grounds of these claims are such as not to request a specific accrual.

Immobiledit S.r.l., the subsidiary merged into Cairo Editore in 2009, is party to a lawsuit regarding a property purchase. In 2004, the Court of Milan, in the first instance, had rejected the adverse party's claims, ordering the adverse party to pay damages, to settle in separate proceedings, and to repay legal expenses. The Court of Appeal has partly reversed the ruling of first instance, ordering Immobiledit to pay for the expenses of first and second instance, rejecting the adverse party's claim



for damages, which has appealed to the Court of Cassation against the rejection. Following Ruling no. 25351/14, the Court of Cassation, rejecting all the other grounds of the main appeal of Italiana Assicurazioni, granted the first ground of appeal concerning compensation for damage suffered by Italiana Assicurazioni for the fitting-out of the property covered by the preliminary contract; the Court referred the case to the Court of Appeal of Milan, in a different formation, which will be called to review the issue of compensation for damage only on the point above; the request for compensation by Italiana Assicurazioni regarding the plea granted by the Court of Cassation amounts to approximately Euro 260 thousand. Italiana Assicurazioni shall re-open the case before the Court of Appeal of Milan by the deadline of 12 January 2016.

28. Related party transactions

Transactions carried out by Cairo Communication with related parties and the effect on the financial statements can be shown as follows:

Receivables and financial assets (€ thousands)	Trade receivables	Other receivables and current assets	Intra-group financial assets	Other current financial assets
Parent UT Communications	61	736	-	-
Subsidiaries of Cairo Communication Group				
Cairo Pubblicità S.p.A.	56,305	174	-	-
Cairo Editore S.p.A.	443	-	-	6,246
Cairo Publishing S.r.l.	49	-	-	150
Il Trovatore S.r.l.	390	-	-	-
La 7 S.r.l.	64	1,654	-	-
Associates of UT Communications Group				
Torino FC S.p.A.	304	-	-	-
Total	57,616	2,564		6,396

Payables and financial liabilities (€ thousands)	Trade payables	Other payables and current liabilities	Intra-group financial payables	Other financial liabilities
Parent UT Communications	-	-	-	-
Subsidiaries of Cairo Communication Group				
Cairo Pubblicità S.p.A.	2,854	-	-	-
Cairo Editore S.p.A.	-	-	-	-
La 7 S.r.l.	52,590	-	-	-
Cairo Publishing S.r.l.	6	-	-	-
Il Trovatore S.r.l.	66	-	-	-



Associates of UT Communications Group					
Torino FC S.p.A.		17		-	-
Total		55,533		-	-
Income and expense (€ thousands)	Operating revenue	Operating costs	Financial income	Financial expense	(Expense)/ Income from investments
Parent UT Communications	-	-	-	-	-
Subsidiaries of Cairo Communication Group					
Cairo Pubblicità S.p.A.	116,038	-	-	-	1,039
Cairo Editore S.p.A.	480	-	-	-	6,246
La 7 S.r.l.	153	(101,831)	-	-	-
Cairo Publishing S.r.l.	-	-	1	-	(200)
Il Trovatore S.r.l.	22	(108)	-	-	-
Associates of UT Communications Group					
Torino FC S.p.A.	100	-	-	-	-
Total	116,792	(101,939)	1		7,085

Income and expense (€ thousands)	Cairo Editore	Cairo Pubblicità	Cairo Publishing	La7	Il Trovatore	Torino FC
INCOME						
Sub-concession payment	-	112,961	-	-	-	-
Administrative services and use of serviced space	480	3,000	-	-	22	100
Recharged costs	-	77	-	153	-	-
Sale of advertising space	-	-	-	-	-	-
Interest income	-	-	1	-	-	-
Dividends	6,246	1,039	-	-	-	-
Total	6,726	117,077	1	153	22	100

	Cairo Editore	Cairo Pubblicità	Cairo Publishing	La7	Il Trovatore	Torino FC
EXPENSE						
Internet services	-	-	-	-	(108)	-
Publishers' fees	-	-	-	(101,831)	-	-
Impairment losses on equity investments	-	-	(200)	-	-	-
Total	-	-	(200)	(101,831)	(108)	-

Cairo Communication supplies a range of services to some of its subsidiaries and associates, mainly relating to management accounting software, use of serviced spaces, administration, finance, treasury, management control, credit management and marketing activities, to allow the individual companies to benefit from economies of scale and more efficient management.

In 2014, Cairo Pubblicità S.p.A. worked for Cairo Communication:

- as sub-lessee of Cairo Communication for TV advertising sales (La7 and theme channels under concession Cartoon Network, Boomerang, and CNN) and Internet advertising sales,
- as sub-lessee for print media advertising sales only for the magazines of Editoriale Genesis.

Under these agreements, Cairo Pubblicità directly invoices customers and returns a percentage of proceeds to the sub-lessor.



In 2014, there were no transactions with the parent (U.T. Communications) or with subsidiaries of the latter, except for the contract with Torino F.C. for the provision of administrative services such as bookkeeping; the agreement sets an annual fee of Euro 100 thousand.

As mentioned earlier, Cairo Communication and its subsidiaries Cairo Editore S.p.A., Cairo Pubblicità S.p.A., Diellesei S.r.l. in liquidation, La7 S.r.l., Cairo Publishing S.r.l., and Cairo Network S.r.l. (former Cairo Sport S.r.l.) participate in the national tax consolidation scheme of U.T. Communications S.p.A.

Fees paid to the directors in 2014 are analyzed in Note 30 “Board of Directors’ and Board of Statutory Auditors’ fees” and in the Remuneration Report, prepared pursuant to art. 123 ter of the TUF.

In 2014, Studio Magnocavallo e Associati, of which lawyer Antonio Magnocavallo is a partner, earned fees for professional services provided to companies of the Cairo Communication Group for approximately Euro 267 thousand.

During the year, no transactions were concluded with members of the Board of Directors, general managers and/or with key management personnel, members of the Board of Statutory Auditors, and the financial reporting manager, further than fees paid and as already shown in this Note.

The procedures adopted by the Group for related party transactions, to ensure transparency and substantial and procedural fairness, made by the Company either directly or through its subsidiaries, are illustrated in the Directors’ Report in the section on the “Report on Corporate Governance”.

29. Risk management

Liquidity risk

Cairo Communication is not exposed to liquidity risk, in that on one hand, significant financial resources are held with a net available positive financial position of Euro 25.8 million, while on the other, it attempts to ensure that an appropriate ability to generate cash is maintained, even under the current market conditions.

An analysis of the company’s equity structure shows both liquidity, or the ability to maintain financial stability in the short term, and solidity, or the ability to maintain financial stability in the medium/long term.

It is Group policy to invest available cash in on-demand or very short-term bank deposits, properly spreading the investments, essentially in banking products, with the prime objective of maintaining a ready liquidity of the said investments. Counterparties are selected on the basis of their credit rating, their reliability and the quality of the service rendered.



Currency and interest rate risks

Cairo Communication is not exposed to these risks, in that on one hand, there is no loan finance, whilst on the other hand operations are carried out exclusively in Italy, and revenue is generated entirely in the country and main costs are incurred in Euro.

Interest rate risk only affects the yield on available cash. Specifically, with reference to the net financial position at 31 December 2014, a one percentage point reduction in the interest rate would result in a reduction in annual financial income of approximately Euro 0.3 million.

Movements in the cash flow and the liquidity of the Company are centrally monitored and managed by Group Treasury in order to guarantee effective and efficient management of financial resources.

Given the limited exposure to both interest rate and FOREX risk, the Company does not use financial derivative and/or hedging instruments.

Credit risk

Cairo Communication is exposed to credit risk, primarily in relation to its advertising sales activities. This risk is however mitigated by the fact that exposure is divided across a large number of customers and that credit monitoring and control procedures are in place.

It is of course possible that the financial crisis and the uncertainty factors in the short and medium term could deteriorate, along with the resulting credit squeeze, and negatively impact on the quality of credit and on general payment terms.

30. Board of Directors' and Board of Statutory Auditors' fees

The following information refers to the 2014 fees paid to Directors, Statutory Auditors, General Managers and key management personnel, also in subsidiaries, analyzed in detail in the Remuneration Report, prepared pursuant to art. 123 ter of the TUF:



Name	Position	Term of office	Term expiry date	Fees *	Benefits in kind	Bonuses and other incentives	Other fees**
Urbano R. Cairo	Chairman of the Board	Jan-Dec 2014	31/12/2016	500	16	-	510
Uberto Fornara	CEO	Jan-Dec 2014	31/12/2016	223	5	-	477
Maria Laura Cairo	Director	May-Dec 2014	31/12/2016	20	-	-	-
Stefania Petruccioli	Director	May-Dec 2014	31/12/2016	32	-	-	-
Roberto Cairo	Director	Jan-Dec 2014	31/12/2016	20	-	-	-
Marco Janni	Director	Jan-Dec 2014	31/12/2016	28	-	-	-
Antonio Magnocavallo	Director	Jan-Dec 2014	31/12/2016	34	-	-	-
Marco Pompignoli	Director	Jan-Dec 2014	31/12/2016	350	5	-	300
Roberto Rezzonico	Director	Jan-Dec 2014	31/12/2016	34	-	-	-
Mauro Sala	Director	Jan-Dec 2014	31/12/2016	32	-	-	-
Key management personnel	N/A	Jan-Dec 2014	N/A	-	15	-	1,218
Marco Moroni	Chairman Board of Statutory Auditors	Jan-Dec 2014	31/12/2016	30	-	-	25
Mariapia Maspes	Standing auditor	Jan-Dec 2014	31/12/2016	20	-	-	17
Marco Giuliani	Standing auditor	Jan-Dec 2014	31/12/2016	20	-	-	-

* Other fees, in addition to fees for the role of director (Euro 20 thousand), refer to:

- Urbano Cairo: fees pursuant to art. 2389, paragraph 3, Italian Civil Code (Euro 480 thousand);
- Uberto Fornara: fees pursuant to art. 2389, paragraph 3, Italian Civil Code (Euro 203 thousand);
- Marco Janni: fees for attendance in meetings of the Related Party Committee (Euro 8 thousand);
- Antonio Magnocavallo: fees for attendance in meetings of the Remuneration Committee and the Control and Risk Committee (Euro 14 thousand);
- Stefania Petruccioli: fees for attendance in meetings of the Remuneration Committee and Related Party Committee (Euro 12 thousand);
- Marco Pompignoli: fees pursuant to art. 2389, paragraph 3, Italian Civil Code (Euro 330 thousand);
- Roberto Rezzonico: fees for attendance in meetings of the Remuneration Committee and Control and Risk Committee (Euro 14 thousand);
- Mauro Sala: fees for attendance in meetings of the Risk and Control Committee and the Related Party Committee (Euro 12 thousand)

** Other fees refer to:

- Urbano Cairo: fees for his duties performed for Cairo Editore (Euro 500 thousand) and other companies of the Group (Euro 10 thousand);
- Uberto Fornara: gross fees as senior manager payable by Cairo Communication (Euro 300 thousand), remuneration from the non-compete agreement (Euro 67 thousand), fees for his duties performed for Cairo Pubblicità (Euro 100 thousand) and other companies of the Group (Euro 10 thousand);
- Marco Pompignoli: gross fees as senior manager payable by Cairo Communication (Euro 200 thousand), and fees for his duties performed for Cairo Pubblicità (Euro 90 thousand) and other companies of the Group (Euro 10 thousand);
- Key management personnel: gross fixed annual Group fees for a total of Euro 1,028 thousand (comprising gross remuneration as manager) and variable incentive components amounting to Euro 190 thousand.



Moreover, under Consob Communication n. DEM/11012984 of 24 February 2011, point 2.3, letters (a) and (f), it should be noted that:

- there are no agreements in place between the Parent and the directors for any indemnity in the event of resignation or unjust dismissal, or in the event their employment relationship ceases following a takeover bid;
- there are agreements in place between the Parent and Uberto Fornara, subject to non-competition commitments for 18 months following termination of his management relationship with the Parent, for payment during his relationship, starting from May 2014, of a gross annual fee of Euro 100,000. In the event of termination of employment before payment, as remuneration for the non-competition agreement, as of May 2014, of the total sum of Euro 450,000, to be considered a minimum consideration of the agreement, the Company will pay the manager the difference between such minimum amount and the amount paid until then as remuneration for the agreement.

Moreover, there are no succession plans regarding executive directors.

At 31 December 2014, key management personnel of the Cairo Communication Group was composed of:

- Giuseppe Ferrauto (Director, General Manager and manager of Cairo Editore);
- Giuliano Cesari (executive director and General Manager of Cairo Pubblicità) and manager of Cairo Communication;
- Marco Ghigliani (CEO, General Manager and manager of La7 S.r.l.).

To date, Cairo Communication has no stock option plans in place.

31. Transactions deriving from atypical and/or unusual or non-recurring transactions

Pursuant to Consob Communication of 28 July 2006 n. DEM/6064296, it should be noted that in 2014 the Cairo Communication Group did not engage in any atypical and/or unusual transactions as defined by the above Communication.



Mention must be made that in 2013 the Cairo Communication Group had finalized the acquisition of the entire share capital of La7 S.r.l.. The transaction, which is considered non-recurring by nature and relevant amount, had generated non-recurring income and charges respectively of Euro 57,066 thousand and Euro 1,917 thousand as discussed in Note 10 to the consolidated financial statements.

For the Board of Directors
Chairman Urbano R. Cairo



Cairo Communication S.p.A.
Financial statements at 31 December 2014 – Annexes
and Appendix



ANNEX 1 - LIST OF INVESTMENTS IN SUBSIDIARIES AND ASSOCIATES

SUBSIDIARIES:

Company name:	Cairo Editore S.p.A.
Registered office:	Milan – Corso Magenta, 55
Share capital:	1,043,256
Equity at 31/12/2013:	8,313,387
Profit at 31/12/2013:	6,248,910
Equity as per draft financial statements at 31/12/2014:	9,533,578
Profit as per draft financial statements at 31/12/2014:	7,469,101
Ownership:	99.95%

Company name:	La 7 S.r.l.
Registered office:	Rome – Via della Pineta Sacchetti 229
Share capital:	1,020,000
Equity at 31/12/2013:	121,560,581
Loss at 31/12/2013:	(54,619,188)
Equity as per draft financial statements at 31/12/2014:	112,658,455
Loss as per draft financial statements at 31/12/2014:	(9,652,127)
Ownership:	100%

Company name:	Il Trovatore S.r.l.
Registered office:	Milan – Via Tucidide, 56
Share capital:	25,000
Equity at 31/12/2013:	63,309
Profit at 31/12/2013:	38,303
Equity as per draft financial statements at 31/12/2014:	182,844
Profit as per draft financial statements at 31/12/2014:	119,535
Ownership:	80%



Company name:	Cairo Pubblicità S.p.A.
Registered office:	Milan – Via Tucidide, 56
Share capital:	2,818,400
Equity at 31/12/13:	5,034,711
Profit at 31/12/13:	1,039,118
Equity as per draft financial statements at 31/12/2014:	3,109,675
Loss as per draft financial statements at 31/12/2014:	(885,918)
Ownership:	100%

Company name:	Diellesei S.r.l. in liquidation
Registered office:	Milan – Via Tucidide, 56
Share capital:	10,000
Equity deficit at 31/12/2013:	(127,465)
Loss at 31/12/2013:	(6,156)
Equity deficit as per draft financial statements at 31/12/2014:	(128,121)
Loss as per draft financial statements at 31/12/2014:	(656)
Ownership	60%

Company name:	Cairo Publishing S.r.l.
Registered office:	Milan – Corso Magenta, 55
Share capital:	10,000
Equity at 31/12/2013:	60,645
Loss at 31/12/2013:	(370,052)
Equity as per draft financial statements at 31/12/2014:	52,491
Loss as per draft financial statements 31/12/2014:	(208,154)
Ownership:	100%

Company name:	Cairo Network S.r.l. (former Cairo Sport S.r.l.)
Registered office:	Milan – Via Tucidide, 56
Share capital:	5,500,000
Equity at 31/12/2013:	9,270
Loss at 31/12/2013:	(1,130)
Equity as per draft financial statements at 31/12/2014:	5,515,210
Loss as per draft financial statements 31/12/2014:	(4,790)
Ownership:	100%



INDIRECT SUBSIDIARIES

Company name:	Edizioni Anabasi S.r.l.	
Registered office:	Milan – Corso Magenta, 55	
Share capital:		10,200
Equity at 31/12/2013:		8,765
Loss at 31/12/2013:		(2,503)
Equity as per draft financial statements at 31/12/2014:		9,209
Loss as per draft financial statements 31/12/2014:		(1,556)
Ownership:		100%



ANNEX 2

Summary figures of draft financial statements of subsidiaries in the advertising segment, il Trovatore and discontinued operations at 31 December 2014

	Cairo Pubblicità Financial statements at 31.12.14	Il Trovatore Financial statements at 31.12.14	Diellesei S.r.l. in liquidation Financial statements at 31.12.14
Assets			
A) Share capital proceeds to be received	0	0	0
B) Intangible fixed assets	189	0	0
Tangible fixed assets	45.566	122	0
Tangible financial assets	1.827	3.873	0
Total non-current assets	47.582	3.995	0
C) Inventories	0	0	0
Receivables	81.031.391	747.895	96.062
Current financial assets	0	0	0
Liquid funds	8.884.899	115.079	128.353
Total current assets	89.916.290	862.974	224.415
D) Prepayments and accrued income	67.156	468	249
Total assets	90.031.028	867.437	224.664
Liabilities			
A) Share capital	2.818.400	25.000	10.000
Income-related and other reserves	1.167.468	2.674	0
Shareholders' contributions to cover losses	9.394	0	61.000
Retained earnings/(losses) carried forward	331	35.635	(198.465)
Net profit/ (loss) for the year	(885.918)	119.535	(656)
Total equity	3.109.675	182.844	(128.121)
B) Provisions for risks and charges	1.376.600	0	63.494
C) Post-employment benefits	1.005.889	12.020	0
D) Payables	84.350.941	672.574	289.291
E) Accrued expenses and deferred income	187.923	0	0
Total liabilities	90.031.028	867.437	224.664
Income statement			
A) Production revenue	156.216.323	896.290	0
B) Production costs	(157.261.590)	(715.247)	(848)
Difference between operating revenue and operating expenses	(1.045.267)	181.043	(848)
C) Net financial income / (expense)	56.104	(775)	(35)
D) Adjustments to financial assets	0	0	0
E) Extraordinary income / (expenses)	0	0	0
Pre-tax profit	(989.163)	180.268	(883)
Income tax	103.245	(60.733)	227
Net profit/ (loss) for the year	(885.918)	119.535	(656)



ANNEX 3

Summary figures of draft financial statements of subsidiaries in the publishing and network operator segments at 31 December 2014

	Cairo Editore	Cairo Publishing	Edizioni Anabasi	LA7	Cairo Network
	Financial statements at 31.12.14	Financial statements at 31.12.14	Financial statements at 31.12.14	Financial statements at 31.12.14	Financial statements at 31.12.14
Assets					
A) Share capital proceeds to be received	0	0	0	0	0
B) Intangible fixed assets	11.607.289	9.338	0	26.364.514	32.927.835
Tangible fixed assets	1.948.350	244	0	6.349.095	0
Tangible financial assets	64.264	0	0	356.860	0
Total non-current assets	13.619.903	9.582	0	33.070.469	32.927.835
C) Inventories	3.043.591	121.281	0	131.433	0
Receivables	26.135.944	1.891.006	7.907	61.329.958	33.271
Current financial assets	0	0	0	0	0
Liquid funds	6.951.318	632.634	11.756	106.518.096	50.363
Total current assets	36.130.853	2.644.921	19.664	167.979.487	83.634
D) Prepayments and accrued income	283.574	1.615	0	475.276	22
Total assets	50.034.330	2.656.118	19.664	201.525.232	33.011.490
Liabilities					
A) Share capital	1.043.256	10.000	10.200	1.020.000	5.500.000
Income-related and other reserves	1.021.221	5.000	129	175.892.924	20.000
Shareholders' contributions	0	0	436	0	0
Retained earnings/(losses carried forward)	0	245.645	0	(54.602.342)	0
Net profit/ (loss) for the year	7.469.101	(208.154)	(1.556)	(9.652.127)	(4.790)
Total equity	9.533.578	52.491	9.209	112.658.455	5.515.210
B) Provisions for risks and charges	515.329	390.749	0	9.135.578	0
Post-employment benefits	2.239.166	175.134	0	8.098.971	0
D) Payables	37.518.168	2.037.744	10.454	71.279.878	27.496.280
E) Accrued expenses and deferred income	228.089	0	0	352.350	0
Total liabilities	50.034.330	2.656.118	19.664	201.525.232	33.011.490
Income statement					
A) Production revenue	97.086.783	1.283.909	0	116.435.175	1.833
B) Production costs	(85.215.860)	(1.550.614)	(1.634)	(133.088.041)	(8.058)
Difference between operating revenue and oper	11.870.923	(266.705)	(1.634)	(16.652.866)	(6.225)
C) Net financial income / (expense)	82.574	1.860	78	1.646.594	(285)
D) Adjustments to financial assets	0	0	0	0	0
E) Extraordinary income / (expenses)	0	0	0	0	0
Pre-tax profit	11.953.497	(264.845)	(1.556)	(15.006.272)	(6.510)
Income tax	(4.484.396)	56.692	0	5.354.145	1720
Net profit/ (loss) for the year	7.469.101	(208.154)	(1.556)	(9.652.127)	(4.790)



ANNEX 4

Summary figures of the most recently approved financial statements of the subsidiaries in the advertising segment, il Trovatore and discontinued operations (31 December 2013)

	Cairo Pubblicità Financial statements at 31.12.13	Il Trovatore Financial statements at 31.12.13	Cairo Sport Financial statements at 31.12.13	Diellesei S.r.l. in liquidation Financial statements at 31.12.13
Assets				
A) Share capital proceeds to be rec	0	0	0	0
B) Intangible fixed assets	221	0	0	0
Tangible fixed assets	31.111	213	0	0
Tangible financial assets	1.827	3.873	0	0
Total non-current assets	33.159	4.086	0	0
C) Inventories	0	0	0	0
Receivables	85.781.209	542.543	2.459	152.061
Current financial assets	0	0	0	0
Liquid funds	8.747.614	21.905	7.528	7.616
Total current assets	94.528.823	564.447	9.987	159.677
D) Prepayments and accrued incom	85.600	468	42	503
Total assets	94.647.581	569.001	10.029	160.180
Liabilities				
A) Share capital	2.818.400	25.000	10.400	10.000
Income-related and other reserv	1.167.468	6	0	0
Shareholders' contributions to c	9.394	0	0	61.000
Retained earnings/(losses carri	331	0	0	(192.309)
Net profit/ (loss) for the year	1.039.118	38.303	(1.130)	(6.156)
Total equity	5.034.711	63.308	9.270	(127.465)
B) Provisions for risks and charges	1.196.612	0	0	64.133
Post-employment benefits	869.756	9.918	0	0
D) Payables	87.167.415	495.775	758	223.512
E) Accrued expenses and deferred	379.087	0	0	0
Total liabilities	94.647.581	569.001	10.029	160.180
Income statement				
A) Production revenue	166.252.600	486.117	260	128
B) Production costs	(164.591.609)	(422.146)	(860)	(944)
Difference between operating re	1.660.992	63.971	(600)	(816)
C) Net financial income / (expense)	182.816	(1.195)	(530)	(331)
D) Adjustments to financial assets	0	0	0	0
E) Extraordinary income / (expenses)	0	0	0	0
Pre-tax profit	1.843.808	62.776	(1.130)	(1.147)
Income tax	(804.689)	(24.473)	0	(5.009)
Net profit/ (loss) for the year	1.039.118	38.303	(1.130)	(6.156)



ANNEX 5

Summary figures of the most recently approved financial statements of the subsidiaries in the publishing segment (31 December 2013).

	Cairo Editore	Cairo Publishing	Edizioni Anabasi	LA7
	Financial statements at 31.12.13	Financial statements at 31.12.13	Financial statements at 31.12.13	Financial statements at 31.12.13
Assets				
A) Share capital proceeds to be received	0	0	0	0
B) Intangible fixed assets	12.826.700	10.076	0	31.984.464
Tangible fixed assets	2.070.143	1.148	0	8.603.809
Tangible financial assets	63.257	0	0	458.330
Total non-current assets	14.960.100	11.223	0	41.046.603
C) Inventories	3.729.675	154.496	0	219.431
Receivables	21.693.431	2.117.044	7.875	66.026.906
Current financial assets	0	0	0	0
Liquid funds	12.518.192	119.936	11.260	115.798.676
Total current assets	37.941.298	2.391.476	19.136	182.045.013
D) Prepayments and accrued income	305.048	1.530	0	692.900
Total assets	53.206.446	2.404.230	19.136	223.784.517
Liabilities				
A) Share capital	1.043.256	10.000	10.200	1.020.000
Income-related and other reserves	1.021.221	5.000	129	175.142.924
Shareholders' contributions	0	0	939	0
Retained earnings/(losses) carried forward	0	415.696	0	16.845
Net profit/ (loss) for the year	6.248.910	(370.052)	(2.503)	(54.619.188)
Total equity	8.313.387	60.645	8.765	121.560.581
B) Provisions for risks and charges	1.857.152	420.851	0	11.283.513
Post-employment benefits	2.351.179	152.547	0	8.137.943
D) Payables	40.584.840	1.770.187	10.370	82.657.738
E) Accrued expenses and deferred income	99.888	0	0	144.742
Total liabilities	53.206.446	2.404.230	19.136	223.784.517
Income statement				
A) Production revenue	100.500.853	1.112.293	500	117.683.940
B) Production costs	(90.360.802)	(1.597.144)	(3.384)	(175.906.665)
Difference between operating revenue and	10.140.051	(484.851)	(2.884)	(58.222.725)
C) Net financial income / (expense)	98.461	6.958	381	1.333.383
D) Adjustments to financial assets	0	0	0	0
E) Extraordinary income / (expenses)	0	0	0	139.629
Pre-tax profit	10.238.512	(477.893)	(2.503)	(56.749.713)
Income tax	(3.989.602)	107.842	0	2.130.525
Net profit/ (loss) for the year	6.248.910	(370.052)	(2.503)	(54.619.188)



APPENDIX

Information pursuant to Article 149-duodecies of Consob Issuers' regulations

The following summary, prepared pursuant to art. 149-xii of Consob Regulations, shows the fees for the current period for auditing services and for non-audit services provided by the Audit Firm.

€ thousands	Services provided by	Fees for the year
Audit		
Parent - Cairo Communication S.p.A.		
	KPMG S.p.A.	75
Subsidiaries		
- Cairo Pubblicità S.p.A.	KPMG S.p.A.	35
- Cairo Editore S.p.A.	KPMG S.p.A.	60
- La7 S.r.l.	KPMG S.p.A.	75
- Cairo Network S.r.l. (former Cairo Sport S.r.l.)	KPMG S.p.A.	17



**CERTIFICATION OF THE SEPARATE FINANCIAL STATEMENTS PURSUANT
TO ARTICLE 81 (TER) OF CONSOB REGULATION 11971 OF 14 MAY 1999 AND
SUBSEQUENT MODIFICATIONS AND AMENDMENTS**

1. The undersigned Urbano Roberto Cairo, as Chairman of the Board of Directors, and Marco Pompignoli, as Financial Reporting Manager of Cairo Communication S.p.A., also in accordance with art. 154 bis, paragraphs 3 and 4 of Legislative Decree n. 58 of 24 February 1998, certify:

- the adequacy of the characteristics of the company and
- the effective application of administrative and accounting procedures for the preparation of the 2014 financial statements.

2. We also certify that

2.1 the separate financial statements at 31 December 2014:

- a) have been prepared in compliance with International Financial Reporting Standards endorsed by the European Union, pursuant to EEC Regulation 1606/2002 of the European Parliament and Council, of 19 July 2002,
- b) are consistent with the accounting records and books of the Company,
- c) give a true and fair view of the financial position and results of operations of the Issuer;

2.2 the Directors' Report contains a reliable analysis on performance and operating results, as well as on the position of the Issuer, together with a description of the principal risks and uncertainties to which it is exposed.

Milan, 13 March 2015

For the Board of Directors

Chairman

.....

.....

(Urbano Roberto Cairo)

Financial Reporting Manager

.....

(Marco Pompignoli)

**Report of the Board of Statutory Auditors to the Shareholders' Meeting of Cairo
Communication S.p.A., pursuant to art. 153 of Legislative Decree 58/1998 and to
art. 2429 of the Italian Civil Code**

Shareholders,

pursuant to art. 2429 of the Italian Civil Code and to art. 153, paragraph 1, of Legislative Decree n. 58 of 24 February 1998, we hereby inform you that during the year ended 31 December 2014, we performed the oversight duties prescribed by law (art. 148 *et seq* of the above-mentioned Legislative Decree), taking also into account the standards of conduct recommended by the Italian Association of Public Accountants and Accounting Professionals, and the relevant instructions provided by CONSOB communications concerning corporate control and the activities of the Board of Statutory Auditors.

The above being stated, these are the results of the prescribed oversight duties performed during the year:

- we attended the Shareholders' Meetings and those of the Board of Directors held during the year, receiving from the Directors, in accordance with their obligations to report to the Board of Statutory Auditors, under art. 150, paragraph 1, of Legislative Decree n. 58/1998, timely and appropriate information on the overall business performance and outlook, and the most relevant transactions, in terms of size and nature, made by the Company and its subsidiaries;
- to the extent of our responsibilities, we gathered information on compliance with the law and bylaws, and oversaw compliance with the principles of proper governance and appropriateness of the Company's organizational structure, through direct observation, through information gathered from the managers of the departments involved, through regular exchange of information with the Audit Firm tasked with the statutory audit of the separate and consolidated financial statements, and by attending the meetings of the Control and Risks Committee, the Remuneration Committee and the Supervisory Body;
- we oversaw the operation and effectiveness of the internal control systems and the adequacy of the administrative-accounting system and, specifically, its reliability to properly illustrate operational events;

- pursuant to art. 19 of Legislative Decree n. 39/2010, which has assigned the Board of Statutory Auditors the role of "Internal Control and Audit Committee", we conducted oversight duties provided therein on: a) the disclosure of financial information; b) effectiveness of the internal control, internal audit and risk management systems; c) the statutory audit of the separate and consolidated financial statements; d) independence of the Audit Firm, through direct observation, information gathered from the managers of the departments involved, and by analyzing the results of the work performed by the Audit Firm. In such context, we took note of the quarterly audits performed by the Audit Firm to ensure that the accounts were kept on a regular basis; we received from the Audit Firm the Reports prescribed by art. 14 and by art. 19, paragraph 3, of Legislative Decree n. 39/2010, as well as the "Annual confirmation of independence", pursuant to art. 17, paragraph 9, lett. a) of the above Decree; we analyzed, again pursuant to art. 17, paragraph 9, lett. a) of the above Decree, the risks regarding independence of the Audit Firm and the measures it adopted to constrain such risks;
- we controlled the proper operation of the audit system on Group companies and the appropriateness of instructions given to them, pursuant also to art. 114, paragraph 2, of Legislative Decree n. 58/1998;
- we took note of the preparation of the Remuneration Report, pursuant to art. 123 *ter* of Legislative Decree n. 58 of 24 February 1998, and to art. 84 *quater* of CONSOB Regulations 11971/1999 ("**Issuers' Regulations**"), with no particular issues to report;
- we controlled the implementation processes of corporate governance rules provided by the Corporate Governance Code of Listed Companies issued by Borsa Italiana S.p.A., as adopted by the Company;
- we oversaw compliance of the internal procedure regarding related-party transactions with the principles contained in the Regulations approved by CONSOB through resolution n. 17221 of 12 March 2010 and subsequent amendments, and compliance with the above Regulations, pursuant to art. 4, paragraph 6;
- we verified compliance with the laws and regulations on the preparation and layout of the separate and consolidated financial statements, as well as the documents attached thereto. Specifically, the separate and consolidated financial statements are accompanied by the prescribed statements of conformity signed by the Chairman of the Board of Directors and by the Financial Reporting Manager, pursuant to art. 81-

ter of CONSOB Regulations n. 11971 of 14 May 1999 and subsequent amendments and supplements thereto;

- verified that the Directors' Report for 2014 complies with the laws and regulations, consistent with the resolutions adopted by the Board of Directors and with the facts illustrated in the separate and consolidated financial statements. The half-year report and quarterly reports were published in accordance with the law and regulations currently in force and required no comments from the Board of Statutory Auditors.

The specific indications to provide with this Report are listed below, in accordance with the provisions of the above-mentioned CONSOB Communication of 6 April 2001 and subsequent amendments:

1. We gathered information on the transactions of major equity and financial relevance made during the period, also through subsidiaries, to verify that they were made in compliance with the law and bylaws and that they were neither imprudent or such as to jeopardize the integrity of corporate assets.

In this regard, more specifically, mention must be made that on 25 June 2014, Cairo Communication completed the acquisition for Euro 31.626 million, in the tender procedure opened by the Ministry of Economic Development and through its subsidiary Cairo Network S.r.l., of the rights to use (for a period of 20 years) the lot of frequencies for digital terrestrial broadcasting systems (2-SFN multiplex indicated as L3 Lot), covering approximately 96.6% of the population.

We certify, therefore, that to the best of our knowledge, the above transactions were based on principles of proper governance and that the issues regarding potential or possible conflicts of interest were carefully assessed.

2. The characteristics of intra-group and related-party transactions put in place in 2014, the parties involved and the relating financial effects were appropriately explained in section 12 "Related-Party Transactions" of the "Report on Corporate Governance and Ownership Structure" in the Directors' Report for the separate and consolidated financial statements for the year ended 31 December 2014, to which reference is made. In this regard, the Board, in the course of its work, did not identify any atypical and/or unusual transactions made during the year with third and/or related parties. Mention must be made that, on 11 November 2010, the Board of Directors of the Company, under CONSOB Resolution n. 17221 of 12 March 2010 and subsequent amendments and supplements, had adopted new

internal procedures governing the decision-making process and the required disclosures regarding related-party transactions (the “**Procedures**”), which came into effect as from 1 January 2011.

Pursuant to art. 4, paragraph 6 of the CONSOB Regulations approved by the above resolution n. 17221/2010, we oversaw:

- i) compliance of the procedures adopted by the Company with the principles contained in the above regulations and their observance;
 - ii) fairness and correspondence of intra-group and related-party transactions with the interests of the Company.
3. In our view, the information provided by the Directors in their Report, pursuant to art. 2428 of the Italian Civil Code (Directors’ Report), regarding atypical and/or unusual transactions and ordinary transactions, under the previous point, is to be considered exhaustive and complete.
 4. KPMG S.p.A., the Audit Firm tasked with performing statutory audit, with which we held regular meetings during the year, today (3 April 2015) issued the Reports under art. 14 of Legislative Decree n. 39/2010, certifying that the separate and consolidated financial statements for the year ended 31 December 2014 are drawn up clearly and give a true and fair view of assets, liabilities, financial position, results of operations and other components of comprehensive income, changes in equity and cash flows of the Company and the Group, and certifying that the Directors’ Report and the disclosures under art. 123-*bis*, paragraph 4, of Legislative Decree n. 58/1998 are consistent with the separate financial statements of the Company and with the consolidated financial statements of the Group. These reports do not contain any issues of note or explanatory comments.
 5. In 2014, the Board received no complaints, pursuant to art. 2408 of the Italian Civil Code.
 6. In 2014, the Board received no complaints from third parties.
 7. In 2014, the Company did not assign KPMG S.p.A. additional non-recurring tasks.
 8. There are no reports of tasks assigned to subjects that are part of the “network” of the Audit Firm KPMG S.p.A..

9. In 2014, the Board issued its opinion as prescribed by law on the determination of compensation to managers holding strategic responsibilities, as established by the Board of Directors on the proposal of the Remuneration Committee.
10. In 2014, the Board of Directors met six times, the Control and Risks Committee four times and the Board of Statutory Auditors four times. The Remuneration Committee met two times in 2014, while the Related Party Committee met only once.
11. The Board of Statutory Auditors acquired knowledge and oversaw compliance with the law and bylaws and observance of the principles of proper governance, ensuring that actions decided and taken by the Directors complied with the law and bylaws, and were made in a perspective of profitability, and that they were neither imprudent nor reckless, or in potential conflict of interest or in contrast with the resolutions adopted by the Shareholders' Meeting, or such as to jeopardize the integrity of corporate assets.
12. With regard to the adequacy of the organizational structure of the Company and of the Group, the oversight duties of the Board of Statutory Auditors were performed by acquiring knowledge of the organizational structure through information gathered from each area, through meetings with the managers of the various departments and with the Audit Firm as part of a regular exchange of data and information.
13. The Board acquired knowledge and oversaw the adequacy and effectiveness of the internal control system, pursuant also to art. 19 of Legislative Decree 39/2010, through regular meetings with the Director in charge of the internal control system and with the internal audit manager, and through the presence of the Chairman of the Board of Statutory Auditors at the meetings of the Control and Risks Committee and of all the members of the Board at the meetings with the Model 231/2001 Supervisory Body.
14. The Board also oversaw the adequacy and reliability of the administrative-accounting system to properly illustrate operational events, through direct observation, through information received by the managers of the departments involved, by examining company documents and by analyzing the results of the work performed by the Audit Firm.

15. The Board controlled the operation of the control system over subsidiaries and the adequacy of the instructions given to the subsidiaries by the Company, pursuant to art. 114, paragraph 2, of Legislative Decree n. 58/98, in order for the Group companies to provide the required information to comply with statutory disclosure obligations. No exceptions were reported in this regard.
16. During the regular meetings held by the Board of Statutory Auditors with the Audit Firm, pursuant to art. 150, paragraph 3, of Legislative Decree n. 58/1998, no relevant issues emerged that need to be mentioned in this Report.
17. The Board also controlled the implementation processes of corporate governance rules prescribed by the Corporate Governance Code of Listed Companies issued by Borsa Italiana S.p.A., as adopted by the Company, reporting no reprehensible aspects;
18. With regard to the oversight duties performed as mentioned above, there were no omissions, reprehensible facts or irregularities reportable to the competent authorities and/or the supervisory boards, or worthy of mention in this Report.
19. Finally, the Board of Statutory Auditors performed its own assessments on compliance with the rules of law regarding the preparation of the draft separate financial statements and consolidated financial statements of the Group for the year ended 31 December 2014, of the relating explanatory notes and the Directors' Report attached thereto, either directly, assisted by department managers or through information received from the Audit Firm.

Specifically, it is acknowledged that the separate and consolidated financial statements of Cairo Communication S.p.A. for the year ended 31 December 2014 were prepared in accordance with the "International Financial Reporting Standards" (IFRS) issued by the International Accounting Standards Board (IASB) and approved by the European Union, and in accordance with the provisions issued in implementation of art. 9 of Legislative Decree n. 38/2005.

Based on the foregoing considerations, with regard to the oversight duties performed during the year, the Board of Statutory Auditors has no remarks to make, pursuant to art. 153 of Legislative Decree n. 158/1998, to the extent of its responsibilities, on the separate and consolidated financial statements, and on the explanatory notes and Directors' Report, agreeing with the proposal of the Board of Directors to allocate profit for the year, and with the proposal to distribute dividends, contained in the Directors' Report to

the IAS/IFRS separate financial statements of Cairo Communication S.p.A.

Milan, 3 April 2015

Board of Statutory Auditors

Marco Moroni (Chairman)

Marco Giuliani

Maria Pia Maspes

The following pages provide a list of the positions of administration and supervision held by the members of the Board of Statutory Auditors in other companies as at the issue date of the Report (Annex pursuant to art. 144 *quinquedecies* of the Issuers' Regulations).

**ANNEX TO THE REPORT OF THE BOARD OF STATUTORY AUDITORS OF CAIRO COMMUNICATION SPA
DRAWN UP PURSUANT TO ART. 153 OF LEGISLATIVE DECREE 58/98**

**List of positions held in Companies as per Book V, Title V, Chapters V, VI and VII of the Italian Civil Code
as at the issue date of the Report
(art. 144-quinquiesdecies Consob Regulations 11971/99)**

N.	Company Name	Position	Until approval of the financial statements
Marco Moroni (Chairman of the Board of Statutory Auditors)			
1	Betfair Italia Srl	Standing Auditor	30/04/2015
2	Cairo Communication Spa	Chairman of the Board of Statutory Auditors	31/12/2016
3	Cairo Editore Spa	Chairman of the Board of Statutory Auditors	31/12/2016
4	Cairo Pubblicità Spa	Chairman of the Board of Statutory Auditors	31/12/2015
5	Caseificio del Cigno Spa	Standing Auditor	31/12/2014
6	Elettrodelta Spa In Liquidazione	Standing Auditor	31/12/2014
7	La7 Srl	Standing Auditor	31/12/2015
8	Locauto Rent Spa	Standing Auditor	31/12/2015
9	Locauto Spa	Standing Auditor	31/12/2015
10	Publicitas International Spa	Standing Auditor	31/12/2015
11	Revicom Srl	Chairman of the Board of Directors	Until revocation
12	Sony Music Entertainment Italy Spa	Standing Auditor	31/03/2016
13	Ut Communications Spa	Chairman of the Board of Statutory Auditors	31/12/2016
14	SCF Consorzio Fonografici	Standing Auditor	31/12/2016
15	Fratelli Giacomel Spa	Standing Auditor	31/12/2016
16	Giacomel Group Srl	Standing Auditor	31/12/2016
17	Asscom Spa	Standing Auditor	31/12/2016
Number of positions held in issuing companies			1
Total number of positions held			17

N.	Company Name	Position	Until approval of the financial statements
Maria Pia Maspes (Standing Auditor)			
1	Cairo Communication Spa	Standing Auditor	31/12/2016
2	Cairo Pubblicità Spa	Standing Auditor	31/12/2015
3	Cairo Editore Spa	Standing Auditor	31/12/2016
4	UT Communications Spa	Standing Auditor	31/12/2016
5	Torino FC Spa	Standing Auditor	31/12/2016
6	LA7 Srl	Standing Auditor	31/12/2015
7	G.B.H Spa	Standing Auditor	31/12/2015
8	Alto Partnes SGR Spa	Standing Auditor	31/12/2015
9	Italholding Spa	Standing Auditor	31/12/2015
10	MAB Spa	Standing Auditor	31/12/2014
11	Eurofly services	Standing Auditor	31/12/2016
12	Kelly service Spa	Standing Auditor	31/12/2014
13	Aliserio Srl	Standing Auditor	31/12/2014
Number of positions held in issuing companies			1
Total number of positions held			13

N.	Company Name	Position	Until approval of the financial statements
Marco Giuliani (Standing Auditor)			
1	Cairo Communication Spa	Standing Auditor	31/12/2016
2	Ali Spa	Standing Auditor	31/08/2015
3	Banca Esperia Spa	Standing Auditor	31/12/2014
4	Banca Mediolanum Spa	Standing Auditor	31/12/2014
5	Mediolanum Fiduciaria Spa	Standing Auditor	31/12/2016
6	Belmond Investimenti Spa	Chairman of the Board of Statutory Auditors	31/12/2014
7	Belmond Italia Spa	Chairman of the Board of Statutory Auditors	31/12/2014
8	Hotel Splendido Srl	Single Statutory Auditor	31/12/2016
9	Mediolanum Gestione Fondi Spa	Standing Auditor	31/12/2015
10	Rothschild Italia Spa	Standing Auditor	31/03/2016
11	Yara Italia Spa	Standing Auditor	31/12/2014
12	Bg Italia Power Spa	Standing Auditor	31/12/2014
13	Space Spa	Standing Auditor	31/12/2015
14	Tioxide Europe Srl	Standing Auditor	31/12/2015
Number of positions held in issuing companies			1
Total number of positions held			14



KPMG S.p.A.
Revisione e organizzazione contabile
Via Vittor Pisani, 25
20124 MILANO MI

Telefono +39 02 6763.1
Telefax +39 02 67632445
e-mail it-fmauditaly@kpmg.it
PEC kpmgspa@pec.kpmg.it

(Translation from the Italian original which remains the definitive version)

Report of the auditors in accordance with articles 14 and 16 of Legislative decree no. 39 of 27 January 2010

To the shareholders of
Cairo Communication S.p.A.

- 1 We have audited the separate financial statements of Cairo Communication S.p.A. as at and for the year ended 31 December 2014, comprising the statement of financial position, income statement, statement of comprehensive income, statement of changes in equity, statement of cash flows and notes thereto. The company's directors are responsible for the preparation of these financial statements in accordance with the International Financial Reporting Standards endorsed by the European Union and the Italian regulations implementing article 9 of Legislative decree no. 38/05. Our responsibility is to express an opinion on these financial statements based on our audit.
- 2 We conducted our audit in accordance with the auditing standards recommended by Consob, the Italian Commission for Listed Companies and the Stock Exchange. Those standards require that we plan and perform the audit to obtain reasonable assurance about whether the separate financial statements are free of material misstatement and are, as a whole, reliable. An audit includes examining, on a test basis, evidence supporting the amounts and disclosures in the financial statements. An audit also includes assessing the accounting principles used and significant estimates made by directors. We believe that our audit provides a reasonable basis for our opinion.

Reference should be made to the report dated 7 April 2014 for our opinion on the prior year separate financial statements, which included the corresponding figures presented for comparative purposes.
- 3 In our opinion, the separate financial statements of Cairo Communication S.p.A. as at and for the year ended 31 December 2014 comply with the International Financial Reporting Standards endorsed by the European Union and the Italian regulations implementing article 9 of Legislative decree no. 38/05. Therefore, they are clearly stated and give a true and fair view of the financial position of Cairo Communication S.p.A. as at 31 December 2014, the results of its operations and its cash flows for the year then ended.

- 4 The directors of Cairo Communication S.p.A. are responsible for the preparation of a directors' report on the financial statements in accordance with the applicable laws and regulations. Our responsibility is to express an opinion on the consistency of the directors' report and its specific section on corporate governance and ownership structure, to the extent of the information required by article 123-bis.1.c/d/f/l/m and article 123-bis.2.b of Legislative decree no. 58/98 with the financial statements to which they refer, as required by the law. For this purpose, we have performed the procedures required by the Italian Standard on Auditing 001 issued by the Italian Accounting Profession and recommended by Consob. In our opinion, the directors' report and the information required by article 123-bis.1.c/d/f/l/m and article 123-bis.2.b of Legislative decree no. 58/98 disclosed in the specific section of such report are consistent with the separate financial statements of Cairo Communication S.p.A. as at and for the year ended 31 December 2014.

Milan, 3 April 2015

KPMG S.p.A.

(signed on the original)

Francesco Spadaro
Director of Audit